

KS06, KS09, KS11 Series
High Torque 60mm, 90mm, and 110mm Frame Sizes (NEMA Sizes 23, 34, 42)

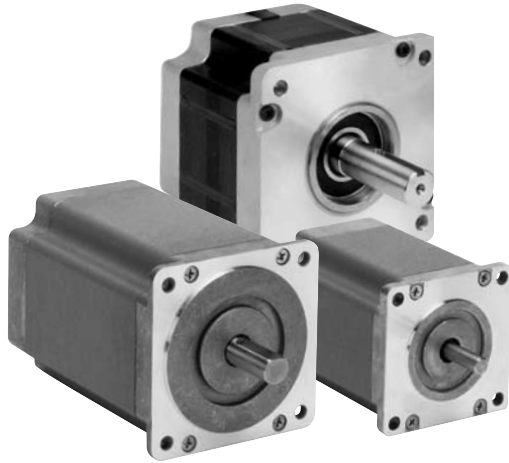

- Latest high torque construction
 - Motor torque up to 1500 oz-in (1059 N-cm)
 - 72 RPM @ 60 Hz - 60 RPM @ 50 Hz
 - 120 and 240 volt AC versions
 - Patented RRC network for smoother operation
 - Leaded or terminal box connections
 - Gearboxes available on KS09, NEMA 34 motors
- See pages 18 & 19 for ratings

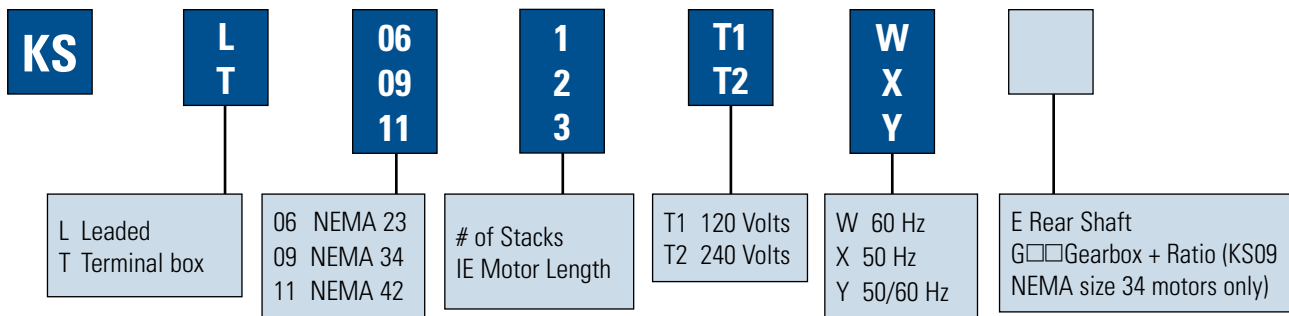

120 Volt, 60 Hz, Single Phase, 72 RPM

	* Type Number	Torque (min)		# Load Inertia		amps	Wiring Diagram	Phase Shifting Components				
		oz-in	N-cm	lb-in ²	kg-cm ²			Resistor(s)			Capacitor (240 VAC)	
								Kit Number	ohms	watt	Kit Number	μF
KS06	^KS□061T1Y	70	49	0.7	2.0	0.25	R/R/C	201052-034	600	12	201053-068	1.5
	KS□061T1Y	80	56	0.5	1.5	0.25	R/C	201052-033	1,000	12	201053-038	2
	KS□062T1Y	140	99	2.0	5.9	0.35	R/C	201052-035	600	25	201053-044	3
	KS□063T1Y	185	131	4.0	12	0.40	R/C	201052-049	400	50	201053-076	5
KS09	KS□091T1Y	240	169	4	12	0.50	R/C	201052-037	300	50	201053-076	5
	KS□092T1Y	450	318	8	23	0.60	R/C	201052-041	250	50	201053-069	6
	KS□093T1Y	700	494	13	38	1.00	R/C	201052-027	150	100	201053-074	11
KS11	KS□111T1W	700	494	7	20	1.20	R/C	201052-045	100	100	201053-032	12.5
	KS□112T1W	1,100	777	13	38	1.70	R/C	201052-101	75	100	201053-081	20
	KS□113T1W	1,500	1,059	15	44	2.10	R/C	201052-104	50	200	201053-081	20

^ Use this RRC phase shifting arrangement if very smooth operation is desired.

KS06, KS09, KS11 Series (Continued)

240 Volt, 60 Hz, Single Phase, 72 RPM

	* Type Number	Torque (min)		# Load Inertia		amps	Wiring Diagram	Phase Shifting Components				
		oz-in	N-cm	lb-in ²	kg-cm ²			Resistor(s)			Capacitor (370 VAC)	
								Kit Number	ohms	watt	Kit Number	μF
KS06	KS□062T2Y	140	99	2.3	6.7	0.15	R/R/C	201052-036	1,100	25	201053-063	0.75
	KS□063T2Y	185	131	2.6	7.6	0.20	R/R/C	201052-050	1,000	25	201053-063	0.75
KS09	KS□091T2Y	240	169	4	12	0.25	R/R/C	201052-039	900	50	201053-070	1
	KS□092T2Y	450	318	9	26	0.35	R/C	201052-045	1,000	100	201053-072	2
	KS□093T2Y	700	494	14	41	0.50	R/C	201052-047	600	100	201053-073	3
KS11	KS□111T2W	700	494	9	26	0.60	R/C	201052-028	500	100	201053-030	3
	KS□112T2W	1,100	777	18	53	0.90	R/C	201052-102	200	100	201053-030	3
	KS□113T2W	1,500	1,059	17	50	1.30	R/C	201052-105	200	200	201053-029	6

240 Volt, 50 Hz, Single Phase, 60 RPM

	* Type Number	Torque (min)		# Load Inertia		amps	Wiring Diagram	Phase Shifting Components				
		oz-in	N-cm	lb-in ²	kg-cm ²			Resistor(s)			Capacitor (370 VAC)	
								Kit Number	ohm	watt	Kit Number	μF
KS06	KS□062T2Y	140	99	2.3	6.7	0.15	R/R/C	201052-036	1,100	25	201053-063	0.75
	KS□063T2Y	185	131	2.6	7.6	0.20	R/R/C	201052-050	1,000	25	201053-070	1
KS09	KS□091T2Y	240	169	4.5	13	0.25	R/R/C	201052-039	900	50	201053-075	1.5
	KS□092T2Y	450	318	8	23	0.35	R/R/C	201052-043	600	50	201053-071	1.75
	KS□093T2Y	700	494	14	41	0.50	R/R/C	201052-046	400	100	201053-073	3
KS11	KS□111T2X	700	494	5	15	0.60	R/C	201052-041	250	50	201053-030	3
	KS□112T2X	1,100	777	18	53	0.70	R/C	201052-103	250	100	201053-028	4
	KS□113T2X	1,500	1,059	27	79.0	1.40	R/C	201052-106	150	200	201053-082	7.5

This is the maximum rigidly attached load inertia the motor will reliably start. If the load is attached to the motor with a coupling that has a 5° flex, the motors can start loads up to seven times listed.

Connection Diagrams

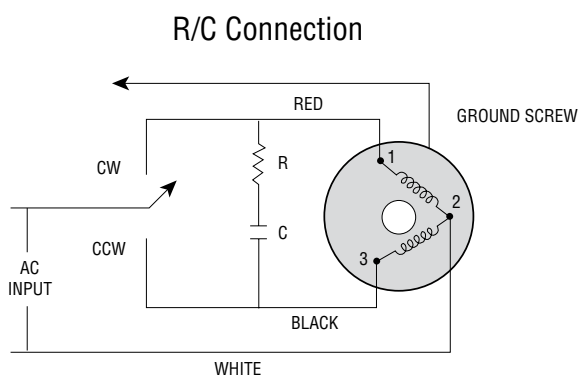

NOTE:
1 - Direction or rotation is determined when viewed from end opposite mounting surface.

Single-Phase Operation

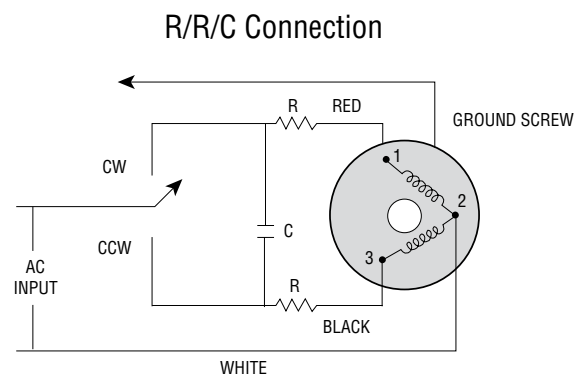

2 - Number in diagrams represent terminal connection when motors are supplied with terminal boards.

Two-Phase Operation

KSL09 Leaded

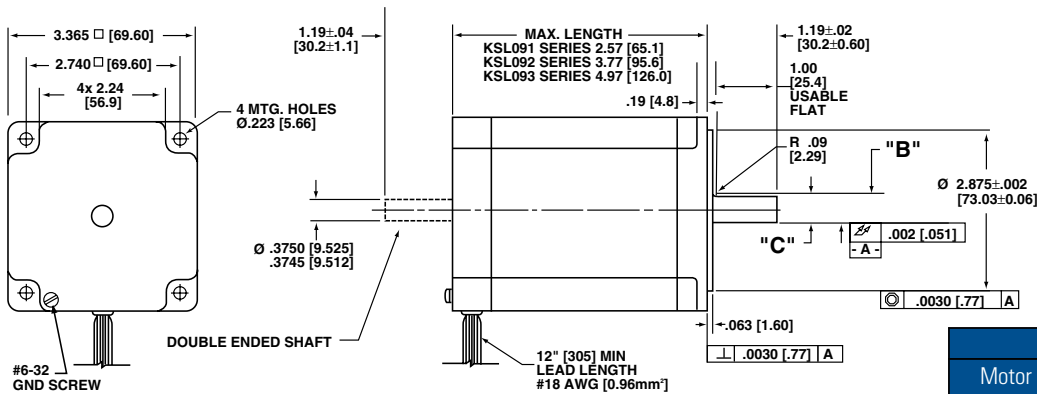

Shaft Dimensions				
Motor Series	"B" Dia.		"C" Flat	
	in	mm	in	mm
KS□091	0.3750	9.525	0.328	8.33
KS□092	0.3745	9.512		
KS□093	0.5000	12.700	0.450	11.43
	0.4995	12.687		

KST09 Terminal Box

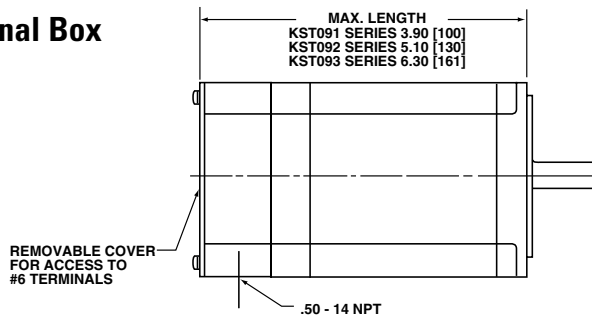

KS09 Gearmotors

See pages 18 & 19 or gearbox information

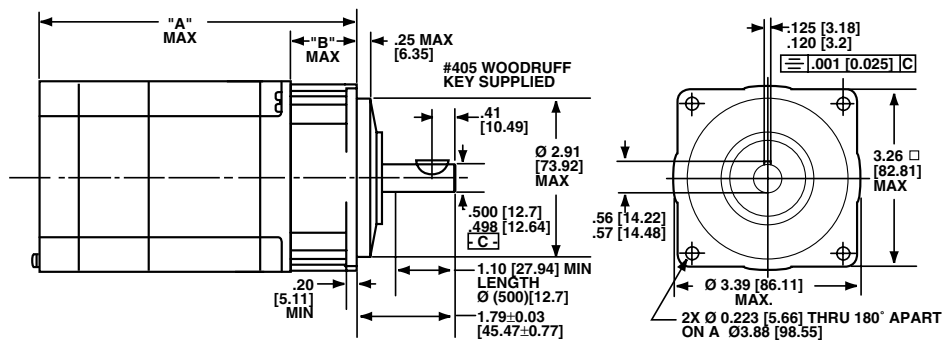

Motor Series	Gearbox Ratio	B		Leaded Motors		Terminal Box Motors			
				Leaded Series	A	Terminal Motors	A		
		inch	mm	inch	mm	inch	mm		
KS□091	3:1 thru 5:1	1.19	30.2	KSL091	3.76	96	KST091	5.09	129
	9:1 thru 25:1	1.81	46.0		4.38	111		5.71	145
	27:1 thru 125:1	2.38	60.5		4.95	126		6.28	160
KS□092	3:1 thru 5:1	1.19	30.2	KSL092	4.96	126	KST092	6.29	160
	9:1 thru 25:1	1.81	46.0		5.58	142		6.91	176
	27:1 thru 125:1	2.38	60.5		6.15	156		7.48	190
KS□093	3:1 thru 5:1	1.19	30.2	KSL093	6.16	156	KST093	7.49	190
	9:1 thru 25:1	1.81	46.0		6.78	172		8.11	206
	27:1 thru 125:1	2.38	60.5		7.35	187		8.68	220

Dimensions are shown in inches (mm)