

Incremental Encoder for Motors M21

Part No. 702150-0005

Edition 3010900hu

Page 1 of 4

Item No. 2 549 002

HENGSTLER

Hengstler GmbH

Postfach 11 51

Tel. 07424 – 890

D-78550 Aldingen

Fax 07424 – 89370

Introduction

These installation instructions are provided for the connection and starting procedure of your shaft encoder.



This sign marks paragraphs particularly to be observed to assure proper use and to avoid risks.

Safety and Operating Instructions

- The incremental shaft encoders of the type M21 model series are quality products manufactured in accordance with established electrical engineering standards.
The units have been delivered from the factory in perfect conformance to safety regulations.
To maintain this condition and to ensure trouble-free operation, please observe the technical specifications of this document.
- **Installation and mounting of electric units may only be done by an electrotechnical expert!**
- The units may only be operated within the limits specified by the technical data.
- **Maximum operating voltages must not be exceeded!**
To prevent dangerous structure-borne currents, the equipment has to be run on safety extra-low voltage (SELV) and must be in an area of equipotential bonding.
Use an external fuse for protection. (see Electrical data)
- Fields of application: industrial processes and controls.
Overvoltage at the connecting terminals must be limited to overvoltage-class-II values.
- This encoder is a supply part destined for mounting to an appliance (motor, machine). It is not provided for customer sale. Manufacturers integrating this encoder to their facilities are responsible as well for compliance with CE guidelines as for the CE mark.
- The assured EMC-specifications are only valid together with output RS 422 and screened cables (Type of connection A ... H).
The cable screen must broadly be connected with ground on the connector end.
- The leads to the power supply should be completely screened. If this is not possible, appropriate filter actions must be taken.
Transient peaks on the power supply leads are to be limited by the pre-connected power unit to a maximum of 1000 V.
- In electrostatically threatened areas please take care for neat ESD-protection of plug and connecting cable during installation work.

Mechanical data

Weight	28 g without cover, 43 g with cover
Dimensions	
Outside diameter	53 mm with cover, 51 mm without cover
Height	20.3 mm with cover excluding connector
Hub diameters	6 mm / 8 mm / 10 mm / 12 mm / 6.35 mm (1/4") / 9.52 mm (3/8") / 11.11 mm (7/16") / 12.7 mm (1/2")
Hub dia. tolerance	+0.026 mm ... -0.000 mm
Shaft endplay	Misalignment axial: +0.13 mm* ... -0.38 mm
Shaft runout	Misalignment radial: 0.05 mm (incl. angular offset)
Length of mounting shaft	16.5 mm min.
	19 mm max. when used with closed cover
Alignment of encoder channels to motor windings	coarse alignment: index mark on the housing and disc/hub; fine alignment: $\pm 15^\circ$ mechanical alignment range
Speed	12000 rpm max.
Moment of inertia	4.7 gcm ²
Protection class (EN 60529)	IP 40 when used with closed cover
Operating temperature	-40 ... +120°C
Storage temperature	-40 ... +120°C
Vibration proof (IEC 68-2-6)	25 m/s ² (5 ... 2000 Hz)
Shock resistance (IEC 68-2-27)	500 m/s ² (11 ms)
Type of connection	radial cable or dual row connector**
Housing	glassfibre-reinforced plastics
* + indicates towards encoder's back (cover)	
** 10 poles (incremental only), 16 poles (incremental+commutation)	

Electrical data

General design	acc. to DIN EN 61010-part 1, protection class III contamination level 2, overvoltage class II	
Supply voltage	5 or 12 V DC $\pm 10\%$ (SELV)	
Intrinsic power consumption	incremental: 100 mA max. commutation: 75 mA max.	
Recommended external fuse	2 x T 0.125 A	
Output circuit	NPN-Open Collector, 16 mA max., Pull-up 2.0 K Ω RS 422, 40 mA max.	
Output signals		
Incremental	NPN-O.C: A, B, N	RS 422: A, B, N, \bar{A} , \bar{B} , \bar{N}
Commutation (optional)	NPN-O.C: U, V, W	RS 422: U, V, W, \bar{U} , \bar{V} , \bar{W}
Tolerance		
Incremental signals	± 5 arc-mins. max. (edge to any edge)	
Commutation signals	± 6 arc-mins. max.	
Phasing		
Incremental signals (A to B)	90° $\pm 18^\circ$ electrical	
Commutation signals	12 pol.: 20°, 8 pol.: 30°, 6 pol.: 40°, 4 pol.: 60° mech.	
Index to U	$\pm 1^\circ$ mech. (index center to U falling edge)	
Pulse width		
Incremental signals	180° $\pm 18^\circ$ electrical	
Commutation signals	12 poles: 30°, 8 poles: 45° 6 poles: 60°, 4 poles: 90° mechanical	
Max. pulse frequency	200 kHz	
Noise immunity*	according to EN 50082-2 (edition 1995)	
Noise emission*	as per EN 50081-2 (edition 1993)	
* The high-quality EMC-specifications are only valid together with output RS 422 and screened cable		

Incremental Encoder for Motors M21

Part No. 702150-0005

Edition 3010900hu

Page 2 of 4

Item No. 2 549 002

Connection diagram cable

Function	Colour incremental only code electrical = 3	Colour incremental + commutation code electrical = 6, 7, 9, A
$V_{cc,com}^{1)}$		red/white ³⁾
$V_{cc,inc}^{1)}$	red	red
GND inc	black	black
GND com		black/white ³⁾
\bar{A}	red/black	blue/black
A	green	blue
\bar{B}	white/black	green/black
B	orange	green
\bar{N}	blue	violet/black
N	white	violet
$\bar{U}^{2)}$		brown/black
U		brown
$\bar{V}^{2)}$		grey/black
V		grey
$\bar{W}^{2)}$		white/black
W		white

¹⁾ $V_{cc,com}$ resp. $V_{cc,inc}$ = +5 V DC or +12 V DC (see Ordering data Electrical)
²⁾ only for output_{com} = RS422
³⁾ not connected for codes 6 and 9, since here $U_{inc} = U_{com}$

Connection diagram connector*

Function	10 poles incr. only, NPN-O.C. code electr. = 0,1	10 poles incr. only, RS422 code electr. =3	16 poles incr. + commutation code electr. = 6, 7, 9
$V_{cc,com}^{1)}$			1
$V_{cc,inc}^{1)}$	2	2	2
GND inc	3	3	3
GND com			4
$\bar{A}^{2)}$		5	5
A	1	1	6
$\bar{B}^{2)}$		7	7
B	8	8	8
$\bar{N}^{2)}$		9	9
N	10	10	10
$\bar{U}^{2)}$			11
U			12
$\bar{V}^{2)}$			13
V			14
$\bar{W}^{2)}$			15
W			16

¹⁾ $V_{cc,com}$ resp. $V_{cc,inc}$ = 5 V DC or 12 V DC (see Ordering data Electrical)
²⁾ only for output_{inc/com} = RS422

* Numbering of pins see mechanical installation drawing

Identification code

Cover

0 without cover

1 closed cover for blind shaft

2 cover with bore for through shaft

Type of connection

0 dual row connector⁵⁾

1...8 dual row connector with ribbon cable⁵⁾

1=30 cm (1 ft), 2=60 cm (2 ft), ...

A...H radial cable, screened³⁾

A=30 cm (1 ft), B=60 cm (2 ft), ...

Number of pulses
incremental

0500

0512 ⁶⁾

1000

1024

2000

2048

Number of poles
commutation

0 none

4 4-poles

6 6-poles

8 8-poles

C 12-poles⁴⁾

Electrical¹⁾
incremental only:

0 $U_{inc}=5\text{ V}$; output_{inc}=NPN-O.C.

1 $U_{inc}=12\text{ V}$; output_{inc}=NPN-O.C.

3 $U_{inc}=5\text{ V}$; output_{inc}=RS 422

incremental+commutation:

6 $U_{inc}=5\text{ V}$; output_{inc}=RS 422,
 $U_{com}=5\text{ V}$; output_{com}=NPN-O.C.

7 $U_{inc}=5\text{ V}$; output_{inc}=RS 422,
 $U_{com}=12\text{ V}$; output_{com}=NPN-O.C.

9 $U_{inc}=5\text{ V}$; output_{inc}=RS 422,
 $U_{com}=5\text{ V}$; output_{com}=RS 422

A as with code 9 but with additional EEPROM

Hub diameter²⁾

A 6.35 mm ($\frac{1}{4}''$)

B 9.52 mm ($\frac{3}{8}''$)

C 11.11 mm ($\frac{7}{16}''$)

D 12.7 mm ($\frac{1}{2}''$)

E 6 mm

F 8 mm

G 10 mm

H 12 mm

¹⁾ U_{inc} : incremental supply voltage

U_{com} : commutation supply voltage (only if commutation is ordered)

²⁾ clamping ring on cover side

³⁾ only possible with output_{inc} = RS 422 (code for electrical 3 3)

⁴⁾ only possible with numbers of pulses 1024 and 2048

⁵⁾ not possible with electrical code A

⁶⁾ only possible with number of poles commutation 0 and 8

Incremental Encoder for Motors M21

Part No. 702150-0005

Edition 3010900hu

Page 3 of 4

Item No. 2 549 002

Mechanical installation

Safety instructions

- All installation work must be carried out according to applicable safety instructions!
- Beware of static discharge. Take common protective measures for your safety as the installation is carried out on the open encoder.
- Touch encoder only at the plastic housing in order to avoid damage to the electronics.
- When adjusting encoder signals, the encoder is under voltage (SELV). To avoid damage to the opened encoder or to the appliance, only electrotechnical experts are allowed to do this work!
- To guarantee sufficient clamping with the hub, please observe the required tolerance for your shaft.

1 Attach mounting holes to B-side motor plate, taking into account

- the angles between mounting axis and cable outlet/connector
- the angles between mounting axis and active index signal.

The mounting in the position indicated in the drawing results in a coarse adjustment of index signal/commutation.

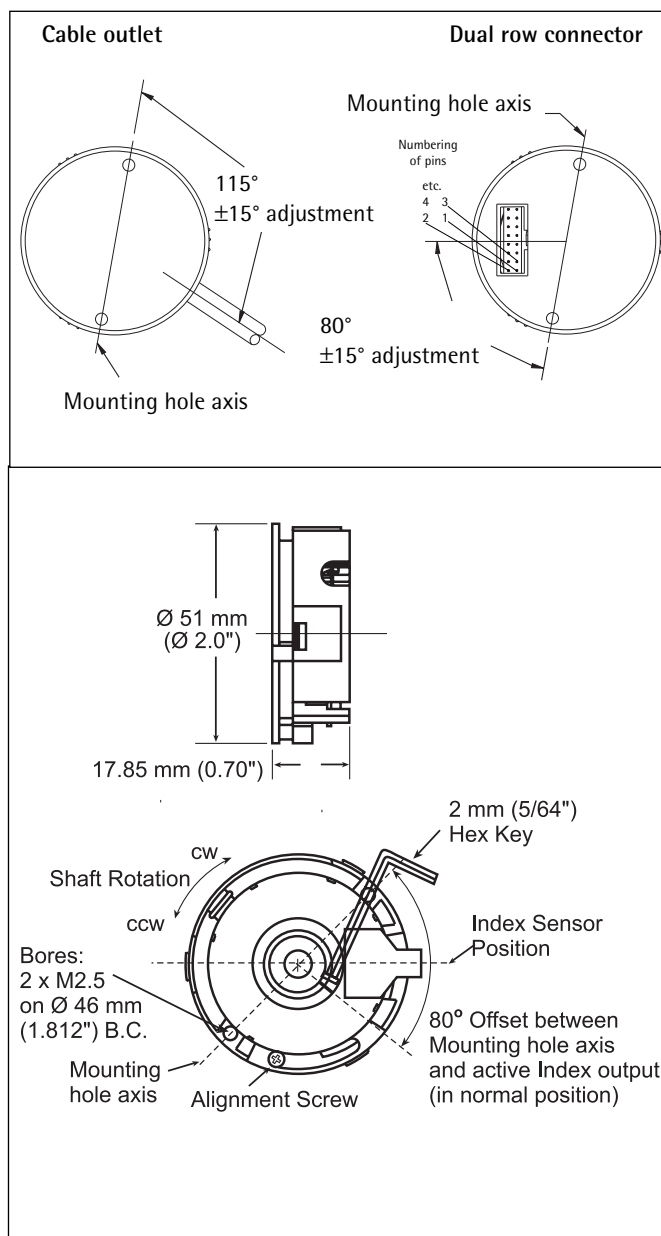

2 (Index signal adjustment only)

Lock the motor shaft in the desired position.

3 (Commutation adjustment only)

The diagram shows the relationship of the brushless AC motor windings to the commutation signals.

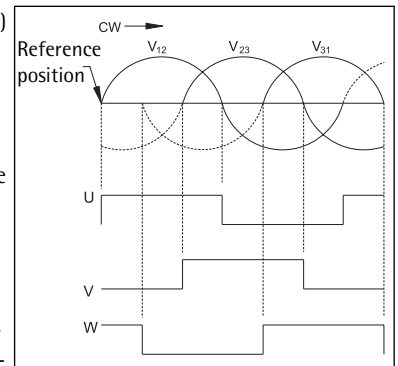

- Apply direct current to the motor winding V_{12} (observe the manufacturer's specifications!).

→ Rotor/shaft of the motor jumps into reference position (positive zero transition of V_{12}) and re-mains fixed in that position.

4 - Hold down the encoder shaft. It is thus centred in the plastic housing.

- Slide the encoder over the motor shaft.

- With the enclosed M2.5 screws, fasten the encoder to the motor plate.

- Align the encoder shaft, as indicated in the drawing, for coarse adjustment of index signal/commutation.

- Hold the pressed-down encoder shaft tight and tighten the screw of the shaft clamping ring to approx. 34 Ncm by means of the enclosed Allen wrench.

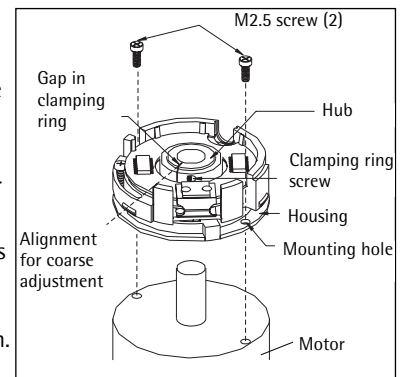

5 Prepare standard position:

- Loosen the alignment screw (1/4 counter-clockwise rotation).

- Rotate the encoder housing through 35° in clockwise direction until the housing slots are aligned with the flange pins.

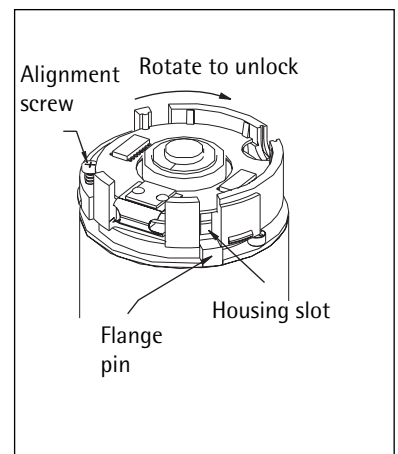

6 (optional)

Index signal fine adjustment:

- Connect encoder operating voltage $V_{cc,inc}$
- Measure output voltage of channel N
- Rotate encoder housing ($\pm 15^\circ$ max.) until index signal applies to output
- Disconnect encoder operating voltage

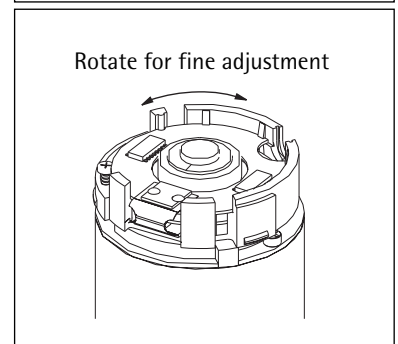

Incremental Encoder for Motors M21

Part No. 702150-0005

Edition 3010900hu

Page 4 of 4

Item No. 2 549 002

7 (optional)

Fine adjustment of commutation:

- Connect encoder operating voltage U_{inc}
- Drive the motor shaft by means of an auxiliary drive (operation of the motor as generator).
- Measure the induced motor winding voltage V_{12} and the encoder output signal U .
- Rotate encoder housing cw or ccw ($\pm 15^\circ$ max.) until phase positions of commutation signal U and motor winding voltage V_{12} are in accordance.
- Disconnect encoder operating voltage.

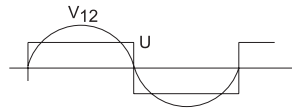

- 8 - Now, tighten the alignment screw to approx. 23 Ncm (2 lb).

9 (optional)

Operation with closed cover:

- Position the housing cover on the encoder (matching with cable or connector termination) and press the cover firmly onto the encoder until the three cover snaps are engaged.

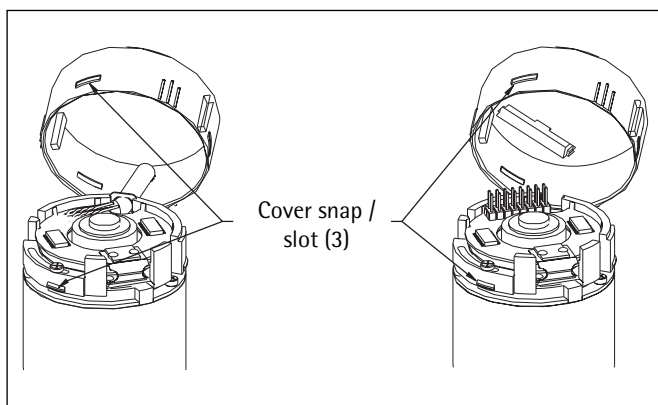

10 Release the motor shaft again.

- Unlock the motor shaft (see step 2)
- Remove the external current supply (see step 3)

When electrically connected, the encoder is now ready for operation.