

ACOMEL



K4000 – Technical Specifications

DANAHER MOTION S.A. La Pierreire 2, CH-1029 Villars-Ste-Croix

Telephone +41-21-631 33 33, Telefax +41-21-636 05 09

E-mail: info@danaher-motion.ch

www.danaher-motion.ch



Modifications are reserved

A comprehensive range of product

Product basics

The **K4000** is a high frequency inverter designed for application up to **4000 Hz**. The **K4000** family consists of several models with output ratings from **5 to 120 kVA**. the selective harmonic suppression **-SHS -** developed by DANAHER MOTION, is aimed at reducing motor losses and winding stresses without output filter.

- The **KEYPAD PC560** control unit can be integrated on the front panel or supplied as a separate remote control unit.
- The drive is equipped with a **RS232 / 422** serial link. A communication protocol in terminal mode for PC is available on request
- The **UL certification of the KT4000 is in process**
- The **19" rack version KL4000** will not be UL certified

Main technical data

- Input voltage, all units, 3 x 200 V to 3 x 480 V auto-ranging, no line transformer
- Output voltage $V_{RMS} : 0 \dots U_{IN}$, max. 3 x 460 V
- Output frequency range 0 ... 4000 Hz
- Ambient temperature 40°C
- Continuous current overload 120% without time limitation
- Max current overload 150% for 1 min / every 10 min
- Short-circuit protection: suitable for use on a circuit capable of delivery not more than 5000 A_{RMS} symmetrical Amperes, 480 V maximum.

Current and Power ratings

Model	Output Current A_{RMS}			Typical motor power kW @ 3 x 400 V
	Nominal	Continuous	Peak	
KT4005	5	6	10	2.5
KT4010	10	12	15	5
KT4015	15	18	23	7.5
KT4020	20	24	30	10
KT4030	30	36	45	15
Input current:	All units are rated for a maximal input current of 32 A_{RMS}			
Input terminals:	10 mm ²			
Input cables:	Minimum section 6 mm ² resp. 10 AWG Use copper conductors 75°C only			

Model	Output Current A_{RMS}			Typical motor power kW @ 3 x 400 V
	Nominal	Continuous	Peak	
KT4040	40	50	60	20
KT4060	60	75	90	30
Input current:	All units are rated for a maximal input current of 63 A_{RMS}			
Input terminals:	35 mm ²			
Input cables:	Minimum section 25 mm ² resp. AWG 4 Use copper conductors 75°C only			

Model	Output Current A_{RMS}			Typical motor power kW @ 3 x 400 V
	Nominal	Continuous	Peak	
KT4090	90	110	135	45
KT4120	120	145	180	60
Input current:	All units are rated for a maximal input current of 160 A_{RMS}			
Input terminals:	70 mm ²			
Input cables:	Minimum section 50 mm ² resp. AWG 1 Use copper conductors 75°C only			

Dissipation and Dynamic Braking Resistors ratings

Model	Dissipation	Braking resistors
	Watts	Ω / Watts - external
KT4005	200	22 Ω /400W
KT4010	400	22 Ω /400W
KT4015	600	22 Ω /400W
KT4020	750	15 Ω /1200W
KT4030	900	15 Ω /1200W
KT4040	1200	6 Ω /1500W
KT4060	1800	6 Ω /1500W
KT4090	2700	4 Ω /2000W
KT4120	3600	4 Ω /2000W

Type Part Numbering

Standalone IP20 units

KT40xx-00	Without PC560 and external dynamic braking resistor
KT40xx-01	Without PC560, with external dynamic braking resistor
KT40xx-10	With PC560 and without external dynamic braking resistor
KT40xx-11	With PC560 and with external dynamic braking resistor

IP54 cabinet unit

KU40xx for cabinet with convection cooling up to KU4015
for cabinet with fan cooling for larger power ratings

KV40xx for cabinet with heat exchanger air – air

KW40xx for cabinet with heat exchanger air – water

KQ40xx for cabinet with air conditioning

Overload protection

UL requires an external overload protection

The dimensions of the KT4000

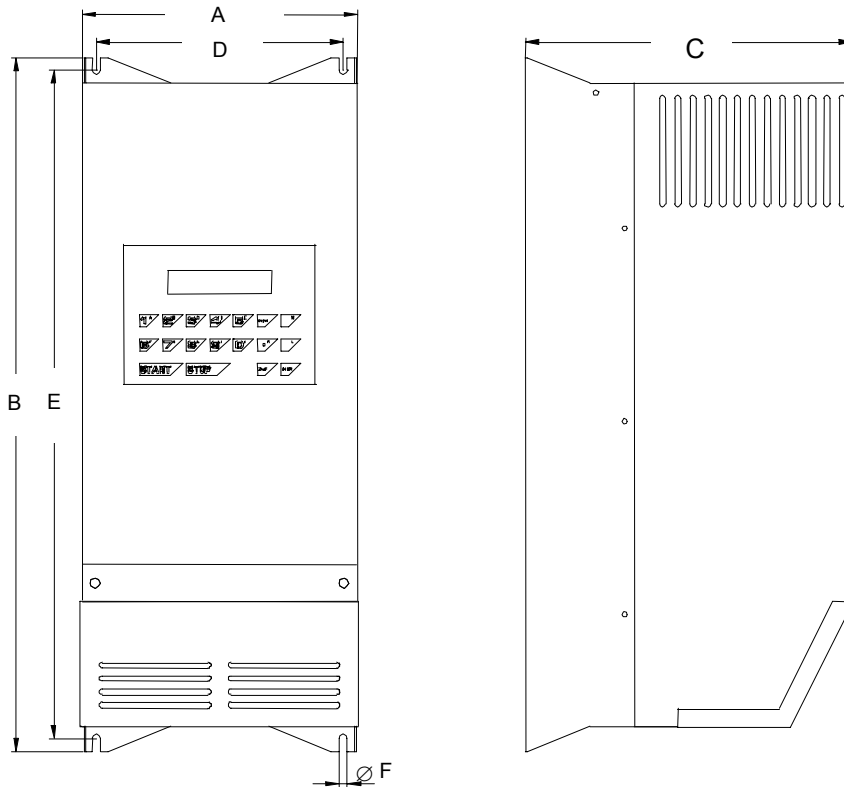

Model	Overall Dimensions			Mounting Dimensions				Weight
	A	B	C	D	E	F	Screws	
KT4005	223	557	265	199	537	7	4 x M6	29 kg
KT4010								
KT4015								
KT4020								
KT4030	484	820	350	450	800	11	4 x M10	71 kg
KT4040								
KT4060								
KT4090								
KT4120								91 kg

All dimensions are in mm

Cabinet enclosure

1. The cabinet size and / or cabinet fan cooling, heat exchanger, air conditioning must be sized according the power dissipation shown on the table page 4.
2. The minimum distances between cabinet walls and the drive (left, right, top and bottom) as well between drives mounted side by side in the same cabinet are 100 mm.

The 19" – rack versions, KL4000

Current and Power ratings

Model	Output Current A_{RMS}			Typical motor power kW @ 3 x 400 V
	Nominal	Continuous	Peak	
KL4005	5	6	10	2.5
KL4010	10	12	15	5
KL4015	15	18	23	7.5
KL4020	20	24	30	10
KL4030	30	36	45	15
Input current:		All units are rated for a maximal input current of 32 A_{RMS}		
Input terminals:		10 mm ²		
Input cables:		Minimum section 6 mm ² resp. 10 AWG Use copper conductors 75°C only		

Type Part Numbering

Connection from front

KL40xx-00F	Without PC560 and external dynamic braking resistor
KL40xx-01F	Without PC560, with external dynamic braking resistor
KL40xx-10F	With PC560 and without external dynamic braking resistor
KL40xx-11F	With PC560 and with external dynamic braking resistor

Connection from rear

KL40xx-00R	Without PC560 and external dynamic braking resistor
KL40xx-01R	Without PC560, with external dynamic braking resistor
KL40xx-10R	With PC560 and without external dynamic braking resistor
KL40xx-11R	With PC560 and with external dynamic braking resistor

The dimensions of the KL4000

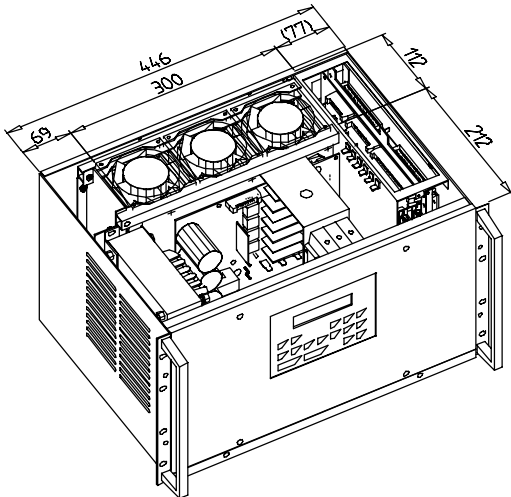

All units have the same dimensions

Mounting Instructions

1. The area on top of the 3 fans, whole width and 112 mm depth, must remain free for correct cooling of the heat sink. At least 50 mm must be available on bottom and top of this area.
2. On the left side they are ventilation opening to allow a correct cooling of the chopper inductance. Those opening must not be covered.

Unit height: 6U = 265.9 mm
Weight: 29 kg

K4000 - Drive overview

The KT4005, KT4010, KT4015, KT4020 and KT4030

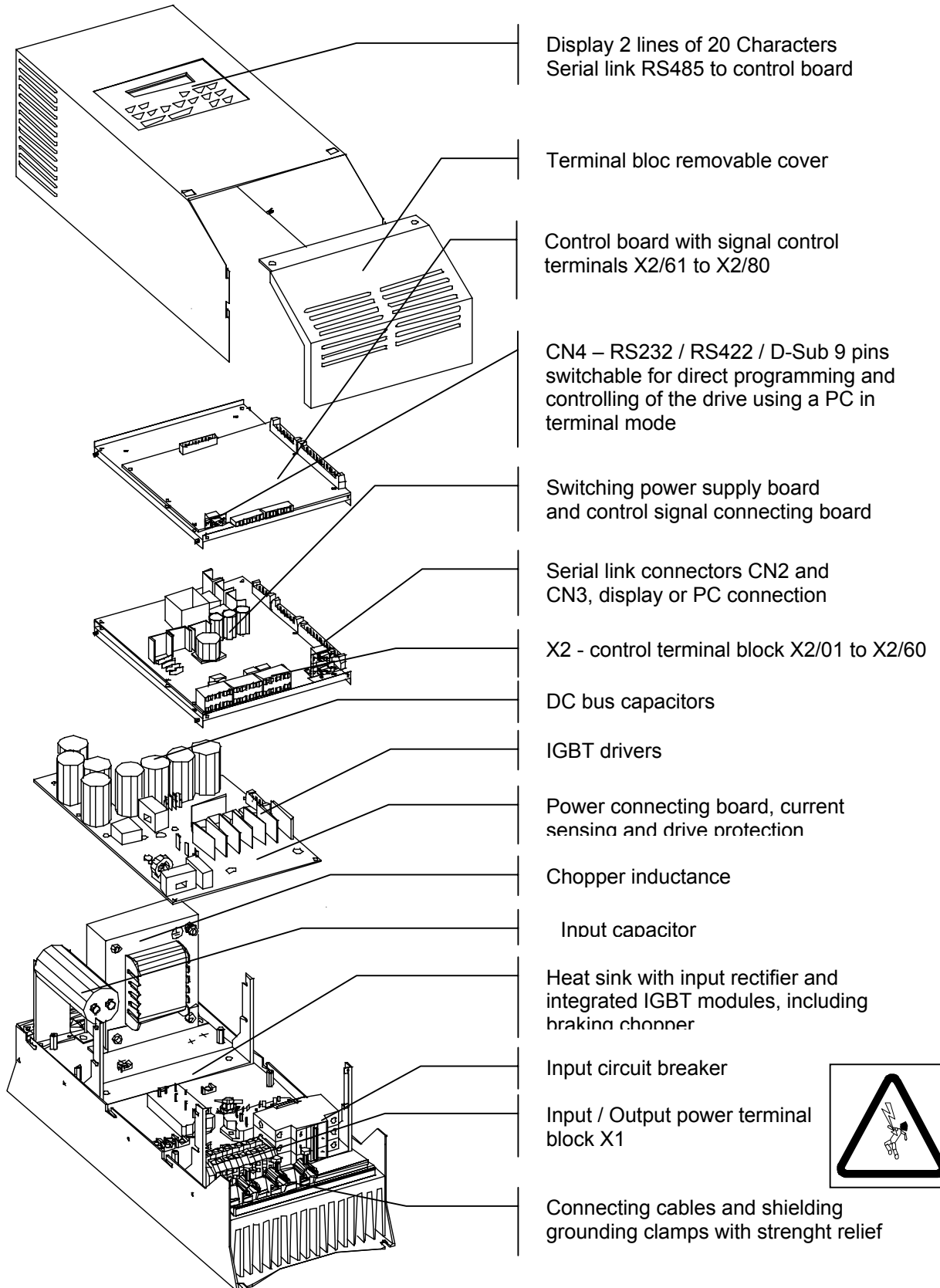

The KT4040 and KT4060

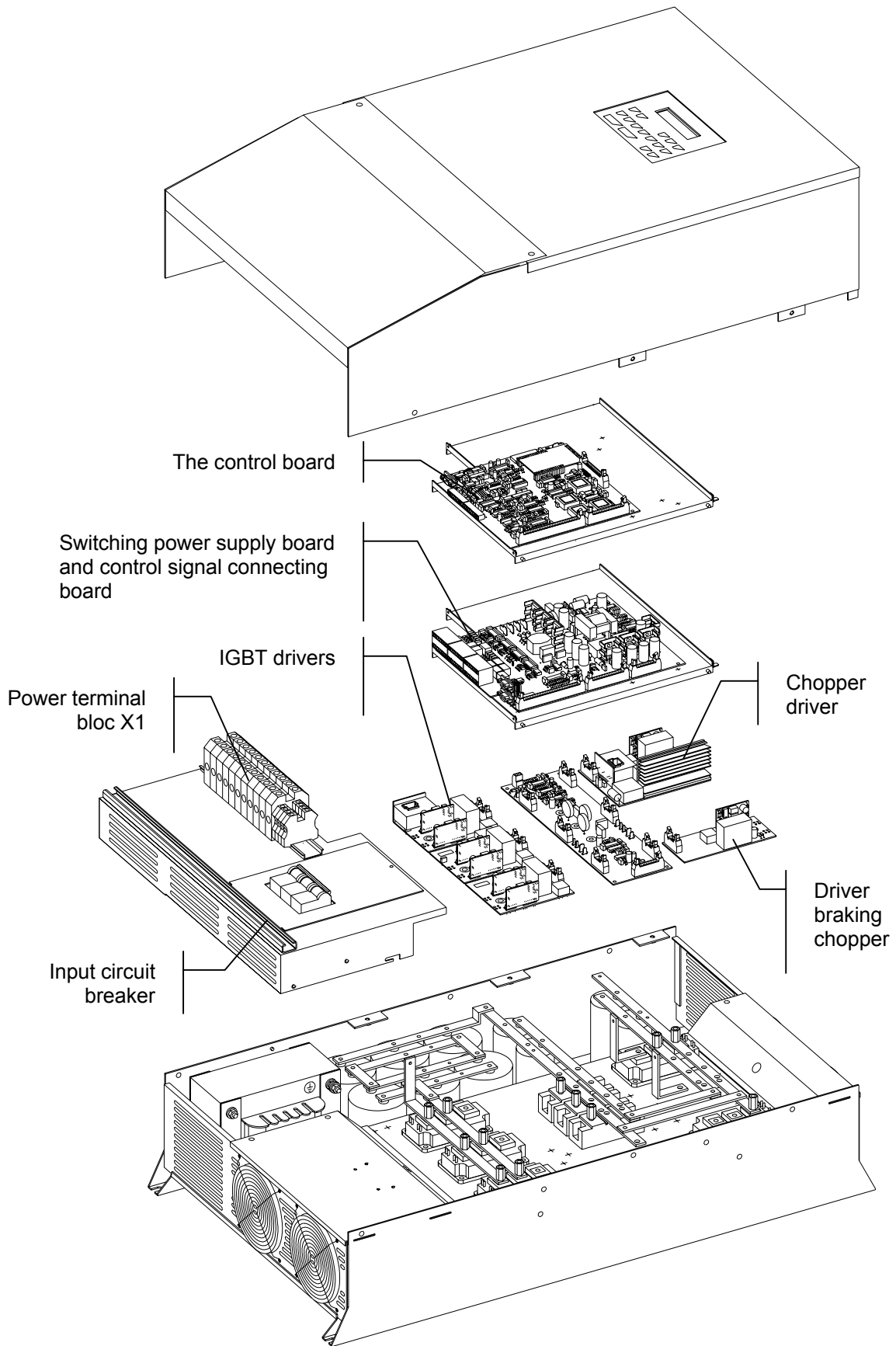

The KT4090 and KT4120

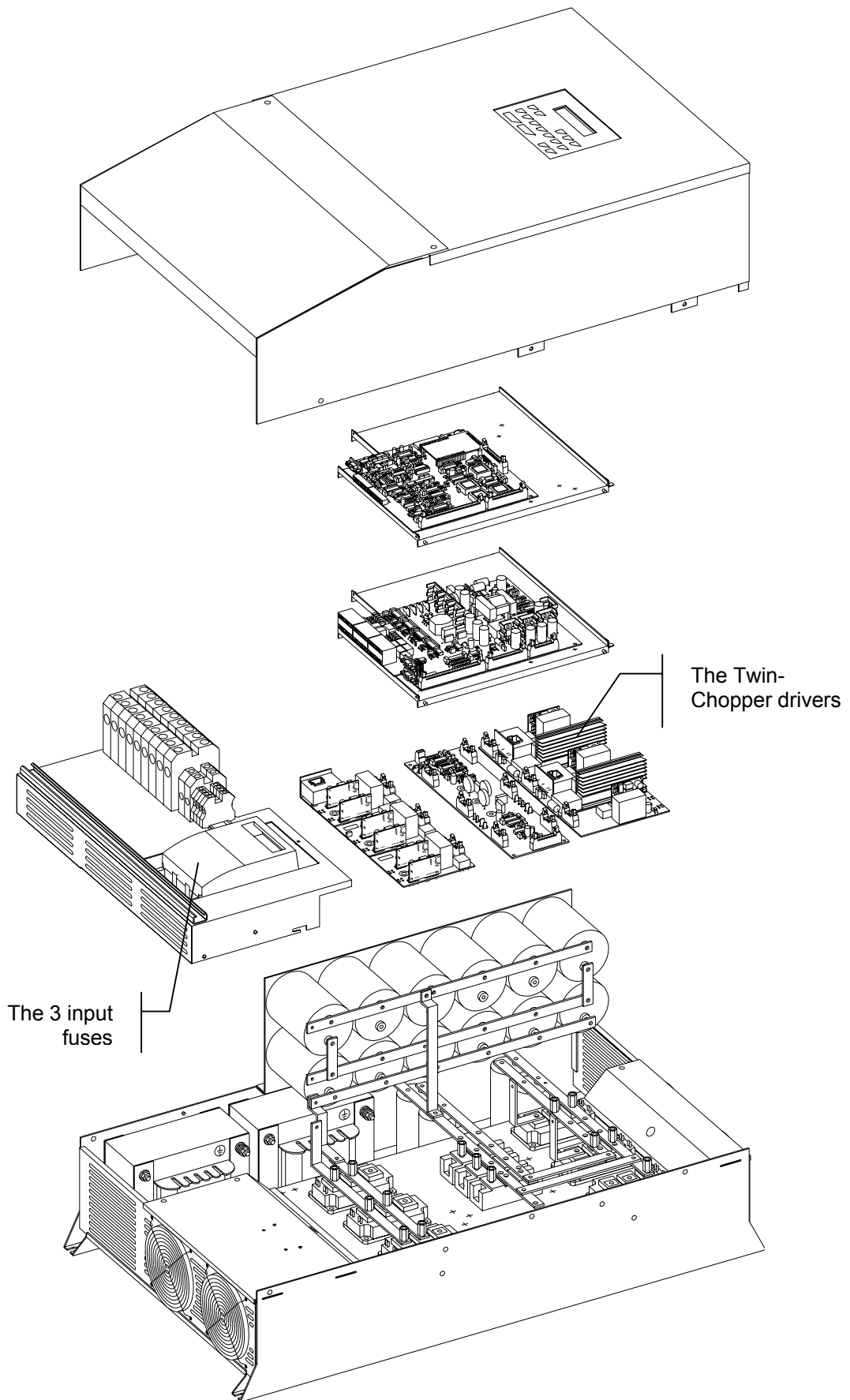

The 19" – rack version KL4000

The terminal blocks, connection for front access:

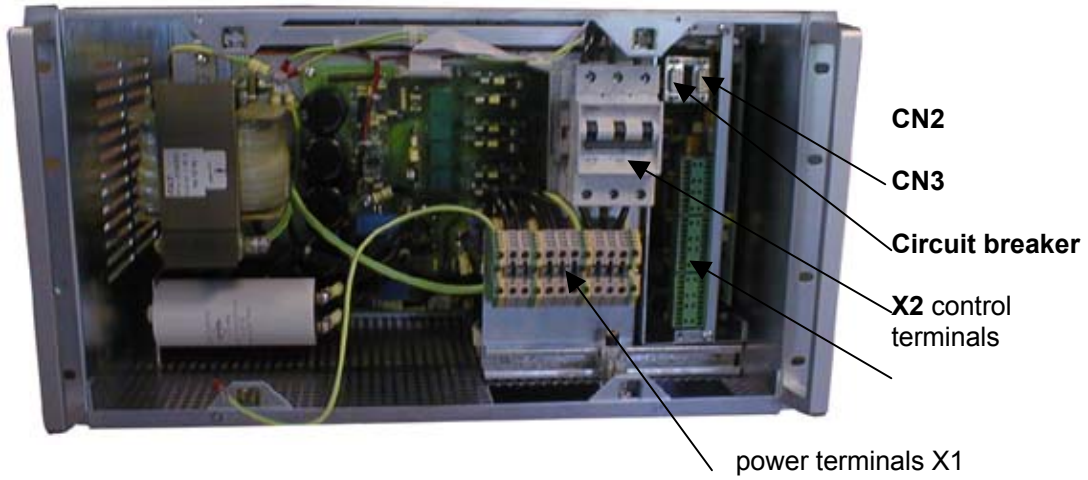

The terminal blocks, connection for access from the back

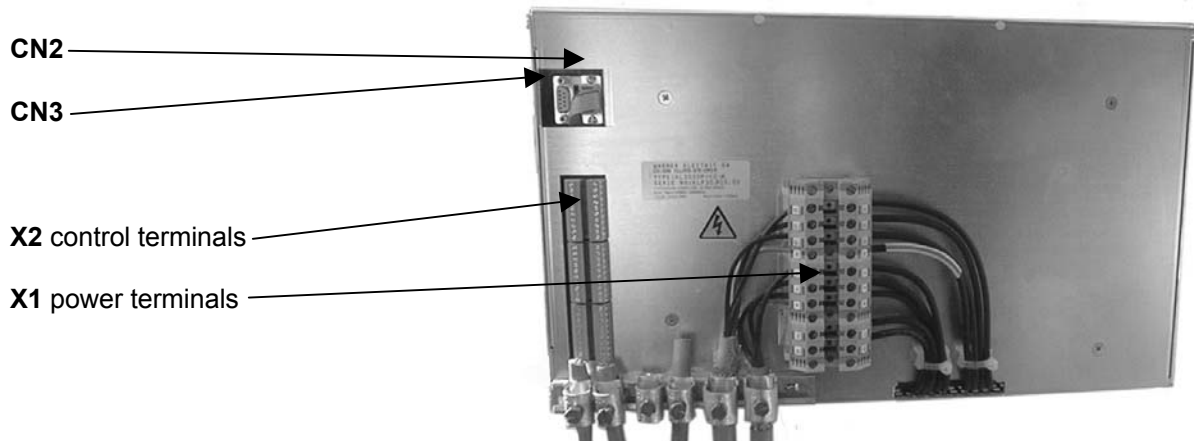

Connecting the dynamic braking resistor

The dynamic braking resistor is a potential free stainless steel heating resistor. The 2 terminals of the resistor connect to the 2 power terminals X1/B.

The kit shown on the picture consists of the resistance with a 200°C temperature sensor (opening contact), a protection grid and mounting accessories.

It is mandatory to connect the temperature sensor to the external interlocks to avoid overheating of the resistance (risk of fire) in case of breakdown of the braking chopper

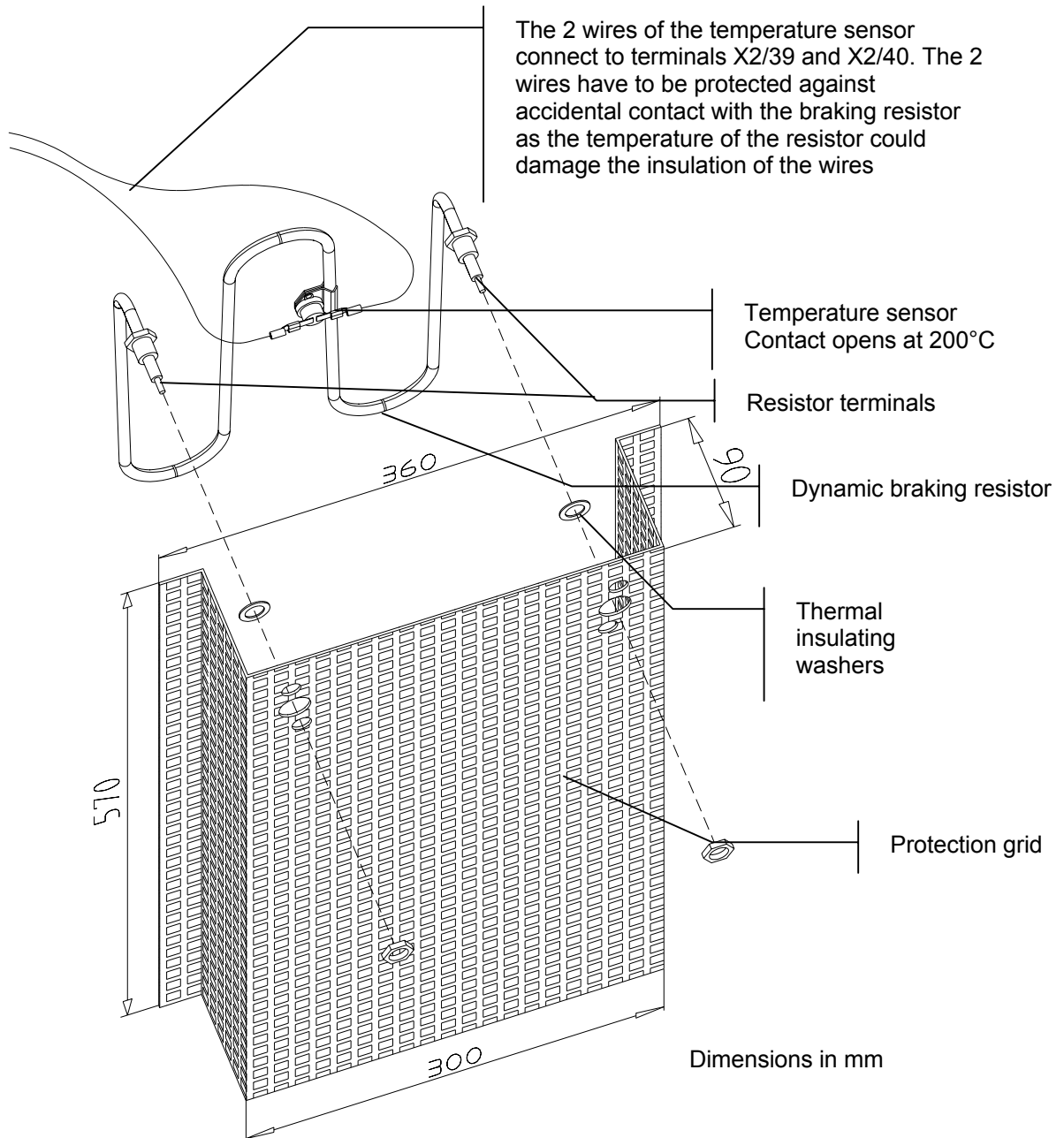

OPTIONS: Temperature sensor rated at lower level than 200°C. The required temperature must clearly be specified on order. The unit will get a specific part number.

The Tachobox Option

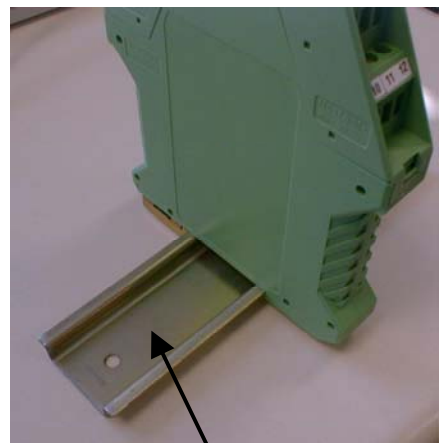
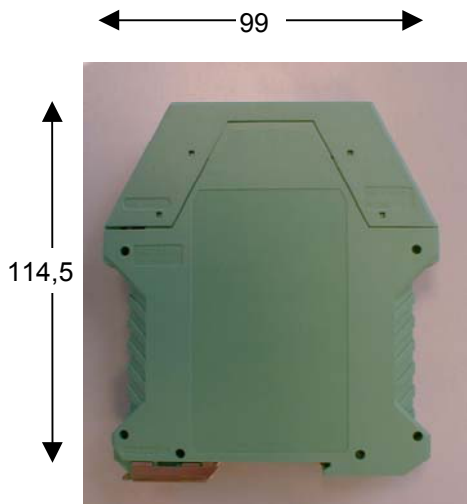
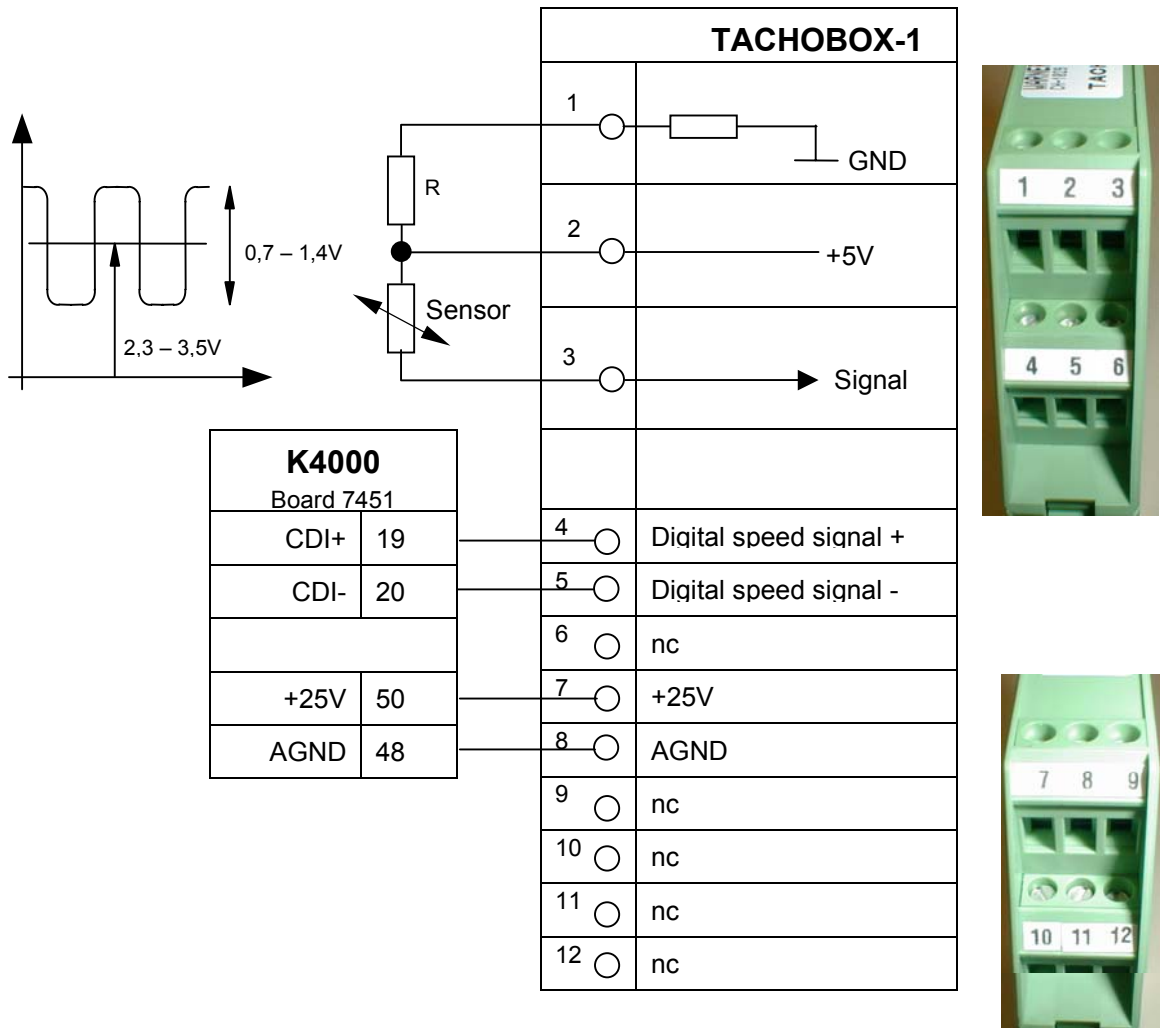

K4000 – List of Error messages

Messages	Explanation
No communication	Fatal error. No communication between the KEYPAD PC580 and the drive. Check connecting cable.
Freq ctrl assigned on T.Block	The speed control function has been assigned to TERMINAL BLOC X2 in menu B and you try to change the speed from the KEYPAD
Partition coding is missing	You selected the partition coding via the terminal block and no selection is made. This message is displayed only after a START command has been issued to the drive.
Partition coding through T.Block	Partition selection is allocated to TERMINAL BLOC X2 and you want to select it using the KEYPAD
Reversing assigned on T.Block	The direction reversing function has been assigned to TERMINAL BLOC X2 in menu B and you try to reverse direction from the KEYPAD
Access locked	The access to Menu B and C is locked by the KEY function on TERMINAL BLOC X2/47 AND X2/48
Motor overload Im>Iref	The converter tripped because the motor current was higher than the programmed reference current. This function is programmed in menu C and a relay will be allocated to it. A time delay can be allocated too.
Please wait before resetting again	Display when trying to do a RESET when the intermediate DC bus voltage is still higher than 30 VDC. Just wait for a while and perform a new reset.
Converter temp. to high !!!	The temperature of the heatsink exceed 75°C
Motor temperature to high (PTC)	Overheating of the motor, detected by the PTC
Motor temperature to high (NTC)	Overheating of the motor, detected by the NTC
External Interlocks !!!	External interlock circuitry open See TERMINAL BLOC X2/39 – X2/40
Converter overloaded	Displayed in case of short-circuit at the output or high current peak exceeding the capacity of the drive.
Defect auxiliary supply !!!	In case of problem with the auxiliary power supply 24, ± 15 or 5 VDC
Mains out of tolerance !! !	Displayed if your mains voltage is lower than 170 VAC respectively higher than 530 VAC. Any value in between is considered being within the tolerances
Failure on module No 1	The output power IGBT No1 is broken
Failure on module No 2	The output power IGBT No2 is broken
Failure on module No 3	The output power IGBT No3 is broken
Failure on Chopper module	The IGBT of the chopper is broken
Failure on Brake module	The IGBT of the braking chopper is broken
"Stop" circuit open !!!	When you try to START. Check connection X2/8 – X2/9 on terminal block. This circuitry must be closed to START.
Switch to catch a spinning motor OPEN	To catch a spinning motor. Check the circuitry X2/45 and X2/46
"Start/Stop" assigned to Terminal Block	START function is allocated to TERMINAL BLOC X2 and you tried to start using the KEYPAD
"Start/Stop" assigned to keypad !!	START function is allocated to KEYPAD and you tried to start using the TERMINAL BLOC X2
Not allowed in STOP !!!"	You tried to reverse direction in STOP
Access forbidden During WORK	The drive is in START mode and you try to access to Menu B or C using the KEYPAD
No errors recorded !!!	Displayed after 2ndF H if the memory of failure is empty

Overview of Menu A, B and C

Menu A: Converter parameters

Display	Please copy Menu A data
Max. current. A	
Softwareversion	
Date of delivery	
Serial number	
Running timer	
Time power applied	

Menu B : Operation / Motors

Display	FS	CS
0=F 1=GB 2=D 3=I 4=E	1	
Menu locking 0=B,C	0	
Start/Stop (choice) 0=PC560	0	
Speed display units 1=rpm	1	
Motor reversing 0=NO	0	
Motor reversing 0=PC560	0	
Filter analog frequency ctrl.	1	
Frequency ctrl 1= 0 to 10V	1	
Mains voltage V	400	
Partition selection 0=PC560	0	
Stop by default ? 0=Coast	0	
Delay time s	0	
Catch spinning mot. 0=NO	0	
PASSWORD:	xxx	
Partition No =	1	
Number of poles	2	
Motor power P(kW)	1	
Iref source 0=PC560	0	
Motor nom. Current Inom A	1	
Current accel/decel Iacc A	1	
Motor current Iref A	1	
If Im>Iref 0=trip	0	
RI-compensation V	0	
Acceleration time s	10	
Deceleration time s	10	
Freq ctrl source 0=PC560	0	
Default frequency Hz	1	
Minimum frequency Hz	1	
Pre-set Frequency 1 Hz	0	
Pre-set frequency 2 Hz	0	
Pre-set frequency 3 Hz	0	
Proh. Frequency 1 Hz	0	
Proh. Band 1 Hz	0	
Proh. Frequency 2 Hz	0	
Proh. Band 2 Hz	0	
Proh. Frequency 3 Hz	0	
Proh. Band 3 Hz	0	
Measure speed 0=no	0	
Nbre pulses/revolution	0	
Slip in %	0	

Display	FS	CS
MCM - 3 = none	3	
Current labs 1 A	0	
Current Ish 1 A	0	
Current IDTO 1 A	0	
Current labs 2 A	0	
Current Ish 2 A	0	
Current IDTO 2 A	0	
Current labs 3 A	0	
Current Ish 3 A	0	
Current IDTO 3 A	0	
FCC duration s	0	
FCC current IFCC A	0	
Permanent current IFCP A	0	
Low freq. smoothing	0	
Slip compensation	0	
Us /Fs Pt. 1 Us = Fs =	1/50	
Us/Fs Pt. 2 Us = Fs =		
Us/Fs Pt. 3 Us = Fs =		
Us/Fs Pt. 4 Us = Fs =		

Menu C : Inputs / Outputs

Display	
Reached frequency	Rel. No = 0
Reached speed	Rel. No = 0
Zero frequency	Rel. No = 0
Zero speed	Rel. No = 0
Start/stop	Rel. No = 0
Motor overload	Rel. No = 0
MCM output	Rel. No = 0
Slip Output	Rel. No = 0
Alarm output	Rel. No = 0
Comp. output	Rel. No = 0
Failure	Rel. No = 5
Ext. interlocks	Rel. No = 0
Converter overload	Rel. No = 0
Def. aux. supply	Rel. No = 0
Motor temp (PTC)	Rel. No = 0
Converter temp (NTC)	Rel. No = 0
Mains anomaly	Rel. No = 0
SAN1:1=Fs, 2=Im, 3=N4=Pw, 5=Iw, 6=Us	Output No 1
SAN2:1=Fs, 2=Im, 3=N4=Pw, 5=Iw, 6=Us	Output No 2
Comp. level V	
Time delay s	

FS : Factory setting
CS : Customer setting



DECLARATION OF CONFORMITY

We: **Danaher Motion S.A**
La Pierreire 2
CH1029 Villars-Ste-Croix

declare under our sole responsibility that the products of the family

K4000

are exclusively designed for incorporation in an other machine. The operation of the product is submitted to the conformity of the complete equipment, following the provisions of the directive **89/392/EEC**

The conformity of the above specified products with the provisions of the Directive **73/23/EEC** is supported by the respect of the standards **CEI/IEC 1010-1**

If the mounting and connecting instructions of the installation's manual have been respected, this product will be conform to the standards **EN50081-1** and **EN50082-1** relating to the EMC directive **89/336/EEC**.

Mounting instructions related to the EMC - directive 89/336/EEC

1. The frequency converter must be mounted in a closed metal cabinet.
2. The power connection between converter and motor must be MADE using shield cable.
3. The control connection must utilize shielded cables.
4. The shield of the cables must be grounded at both ends.
5. Power connections and control connection must be placed in separated canals.
6. A line filter must be installed. The machine manufacturer has the option to use a single filter for all of his equipment. In this case the correct definition and sizing of the filter is his responsibility. If the option of a separate filter is selected, this filter will have to match the following specification:

Units	Filter type	I _{Nom} (A)
K4005	FMAC0932-2510	25
K4010	FMAC0932-2510	25
K4015	FMAC0932-2510	25
K4020	FMAC0934-3610	36
K4030	FMAC0934-3610	36
K4040	FMAC-0934-5010	50
K4060	FMAC-0937-8010	80
K4090	FMAC-0954-H110	110
K4120	FMAC-0955-H210	180

Supplier: Timonta, Mendrisio (Switzerland)

Villars-Ste-Croix, July 2002
The Engineering Manager: A. Schwendener

