



# High performance Step Motors

## POWERMAX II<sup>®</sup> Series P and M

## POWERPAC<sup>™</sup> Series N and K

Product Manual  
Edition 05/2007



As part of the product, you should keep the manual for the product's entire service life. Give the manual to the next owner or user of the product.



**Version History:**

<b>Edition/Date</b>	<b>Reason for Revision</b>
10/2004	Initial release
05/2007	Design

Printed in Germany. All rights reserved.

Subject to technical modifications introduced to improve the equipment!  
No part of this document may be reproduced in any way (by print, photocopy, microfilm or any other procedure) without written consent nor may it be processed, reproduced or disseminated using electronic systems.

## Table of Contents

1.	General .....	4
1.1.	Motor Design .....	4
1.1.1.	Sigma <sup>®</sup> Technology .....	4
1.1.2.	Design POWERMAX II <sup>®</sup> Series P and M .....	5
1.1.3.	Design POWERPAC <sup>™</sup> Series N and K .....	5
1.2.	General Technical Features .....	6
1.3.	Frame Sizes and Torque Ranges.....	7
1.4.	Standard Version.....	7
1.5.	Options .....	7
1.6.	Type Code .....	8
2.	Technical Data.....	9
2.1.	Powermax II <sup>®</sup> Series P and M.....	9
2.1.1.	Data P Series (Standard), NEMA 23.....	9
2.1.2.	Data M Series (Sigma <sup>®</sup> ), NEMA 23 .....	10
2.1.3.	Torque Characteristics POWERMAX II <sup>®</sup> .....	11
2.1.4.	Dimensions POWERMAX II <sup>®</sup> Series P and M.....	12
2.2.	POWERPAC <sup>™</sup> Series N and K.....	13
2.2.1.	Data N Series (Standard), NEMA 34.....	13
2.2.2.	Data K Series (Sigma <sup>®</sup> ), NEMA 34.....	15
2.2.3.	Data N Series (Standard), NEMA 42.....	17
2.2.4.	Data K Series (SIGMAX <sup>®</sup> ) - NEMA 42.....	18
2.2.5.	Torque Characteristics POWERPAC <sup>™</sup> .....	20
2.2.6.	Dimensions POWERPAC <sup>™</sup> , NEMA 34.....	21
2.2.7.	Dimensions POWERPAC <sup>™</sup> , NEMA 42.....	22
3.	Electrical Connections .....	23

# 1. General

## 1.1. Motor Design

The POWERPAC™ and POWERMAX II® Step motors provide an excellent torque to frame size ratio. Optimized magnetic design in combination with a new rotor/stator design produce more torque and a higher acceleration. This unique design also reduces the detent torque for smoother microstepping. The motors are available in several frame sizes and offer holding torques of 0,42 Nm up to 40,2 Nm. The motors of the M and K series incorporate the patented flux focusing technology (Sigmax®) and provide a performance increase of 20% to 30% at identical motor size.

### 1.1.1. Sigmax® Technology

Due to their unique stator construction the Sigmax® motors produce a higher torque rate than comparably sized standard motors. Thin rare-earth-magnets are embedded into the stator gashes. The polarization concentrates the flux which is produced in the rotor magnets onto the stator teeth. Thus the flux leakage that occurs on certain rotor-to-stator positions is inhibited.

Standard Hybrid Step Motor (Series P and N)

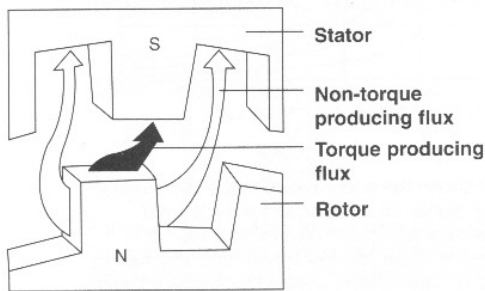

Typical path of flux transfer in an energized conventional hybrid step motor. Some flux leakage occurs in normal operation.

Sigmax® Hybrid Step Motor (Series M and K)

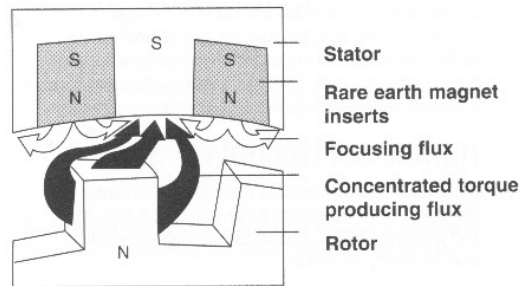

Patented Sigmax® technology redirects magnetic flux to inhibit leakage and optimize torque production.

### 1.1.2. Design POWERMAX II® Series P and M

The motors in size NEMA 23 have an octagonal housing. In standard version all motors have an 8-pole connector.

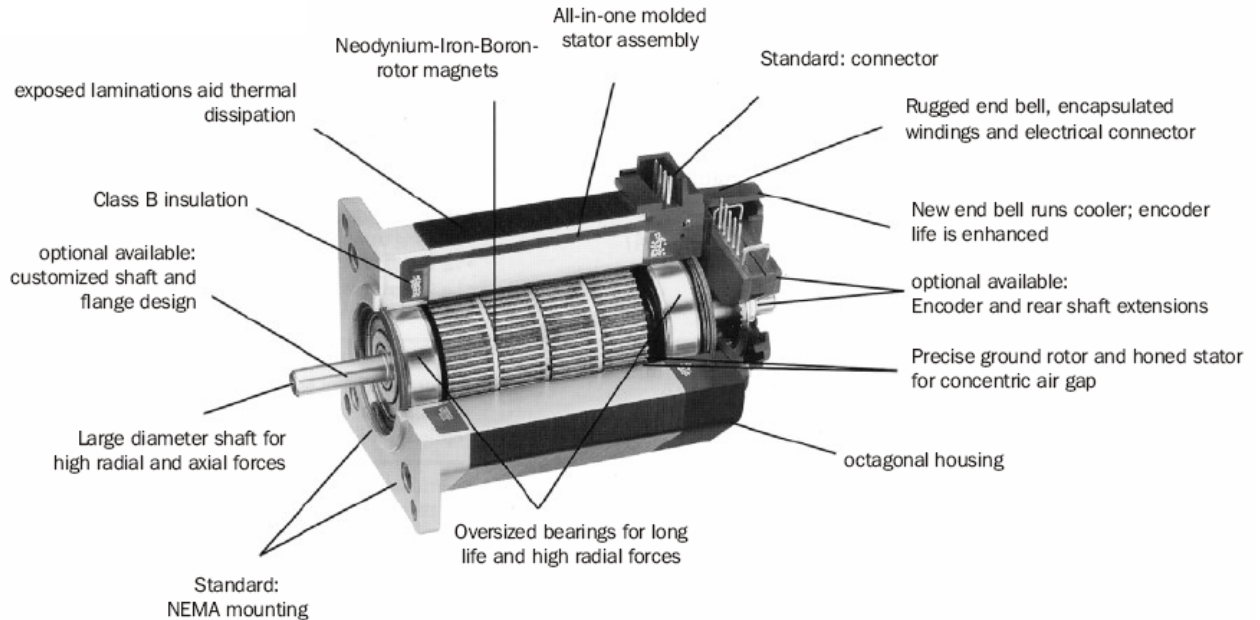

### 1.1.3. Design POWERPAC™ Series N and K

The motors in size NEMA 34 and 42 have a square housing. In standard version all motors have an 8-pole flying lead connection.

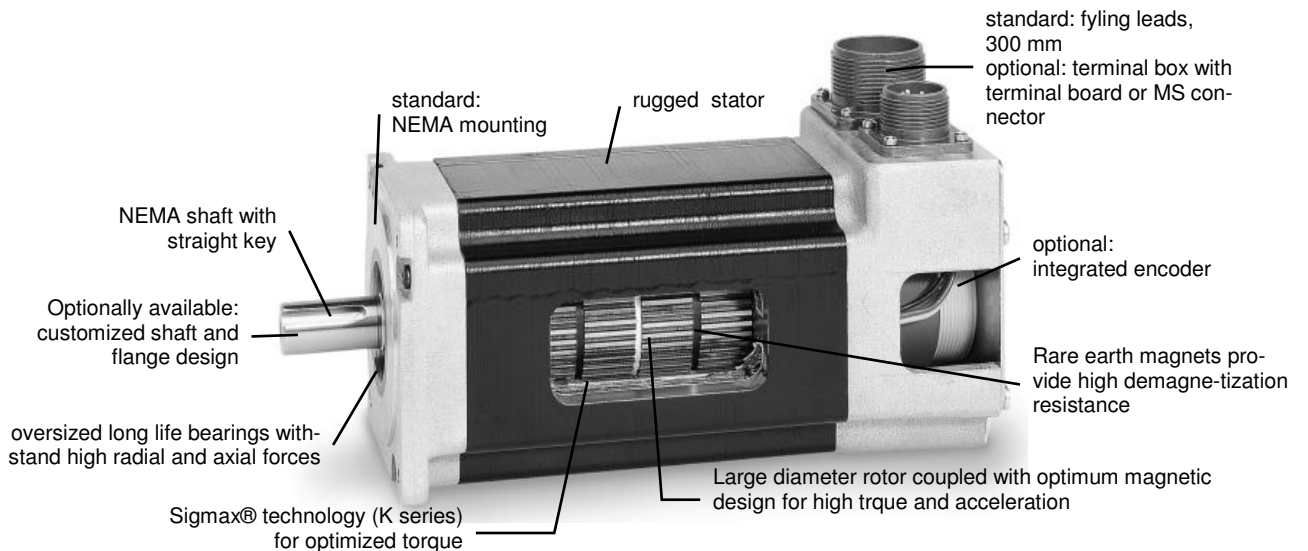

## 1.2. General Technical Features

### POWERMAX II® Series P and M

**Motor Type:**

P series: Hybrid step motors

M series: Hybrid step motors with rare-earth-magnets stator

- **Rotor Construction:**  
laminated (hoher Wirkungsgrad bei hohen Drehzahlen)
- **Phases:** 2
- **Full Steps:** 200 pro revolution
- **Full Step Angle:** 1,8°
- **Angular Accuracy:**  
M series: ± 1,5% of one full step, no load  
P series: ± 3% of one full step, no load
- **Operating Temperature:** -20°C to +40°C
- **Insulation:** NEMA class B, 130°C
- **Protection Class:** IP 23
- **Insulation Resistance:**  
100 MΩ at 500 V<sub>DC</sub> and 25°C
- **Shaft Loading:**  
Max. radial load (regarding to half the shaft length distance to the bearing) = 90 N  
Max. axial load = 60 N

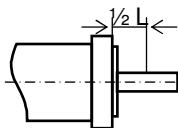

- **Lifetime of Bearings:**  
At least 10.000 hours at speeds up to 10.000 full steps per second, if the motor is used within the above mentioned radial and axial shaft load ranges.

### POWERPAC™ Series N and K

**Motor Type:**

N series: Hybrid step motors

K series: Hybrid step motors with rare-earth-magnets stator

- **Rotorkonstruktion:**  
laminiert (hoher Wirkungsgrad bei hohen Drehzahlen)
- **Phases:** 2
- **Full Steps:** 200 pro revolution
- **Full Step Angle:** 1,8°
- **Angular Accuracy:**  
K series: ± 1,5% of one full step, no load  
N series: ± 3% of one full step, no load
- **Operating Temperature:** -20°C to +40°C
- **Insulation:** NEMA class B, 130°C
- **Protection Class:** IP 44, optional IP 65
- **Insulation Resistance:**  
100 MΩ at 500 V<sub>DC</sub> and 25°C

• **Shaft Loading:**

Motor size	Max. axial load	Max. radial load <sup>*)</sup>
31, 32	1355 N	290 N
33, 34	1355 N	490 N
41	1800 N	560 N
42, 43	1800 N	490 N

<sup>\*)</sup> regarding to half the shaft length distance to the bearing (s. drawing on the left)

- **Lifetime of Bearings:**  
At least 10.000 hours at speeds up to 10.000 full steps per second, if the motor is used within the above mentioned radial and axial shaft load ranges

### 1.3. Frame Sizes and Torque Ranges

Motor Type		Size	NEMA 23	NEMA 34	NEMA 42	Page
Powermax	P-Series (Standard)	½ Stack	0,42 - 0,43 Nm			8
		1 Stack	0,77 - 0,82 Nm			8
		2 Stacks	1,39 - 1,51 Nm			9
	M-Series (Sigmax®)	1 Stack	0,95 - 1,02 Nm			9
		2 Stacks	1,62 - 1,79 Nm			10
Powerpac	N-Series (Standard)	1 Stack		4,5 - 4,7 Nm	11,5 - 11,7 Nm	12/16
		2 Stacks		8,4 - 8,8 Nm	21,8 - 22,2 Nm	12/16
		3 Stacks		12,1 - 13,0 Nm	30,0 - 30,8 Nm	13/17
		4 Stacks		14,36 - 15,4 Nm		13
	K-Series (Sigmax®)	1 Stack		5,7 - 6,0 Nm	14,8 - 15,1 Nm	14/17
		2 Stacks		10,7 - 11,15 Nm	27,8 - 28,4 Nm	14/18
		3 Stacks		15,1 - 16,5 Nm	39,7 - 40,23 Nm	15/18
		4 Stacks		18,2 - 19,7 Nm		15

### 1.4. Standard Version

#### POWERMAX II® Series P and M

- NEMA 23
- 8 lead connector for serial or parallel connection
- Single shaft end, smooth shaft Ø 6,35 mm
- Connector cable KAB.300 has to be ordered separately

#### POWERPAC™ Series N and K

- NEMA 34 or NEMA 42
- 8 flying leads for serial or parallel connection
- Single shaft end with straight keyway
- CE certification (EN60034-1)
- UL certification (motor insulation class B, File E103510)

### 1.5. Options

- Various encoders
- Various gearboxes
- Brake
- Rear shaft extension
- Various hook-up versions
- Low inertia rotor (Powermax only)

Further types and options for this series as well as stepper drives and other accessories are available upon request.

## 1.6. Type Code

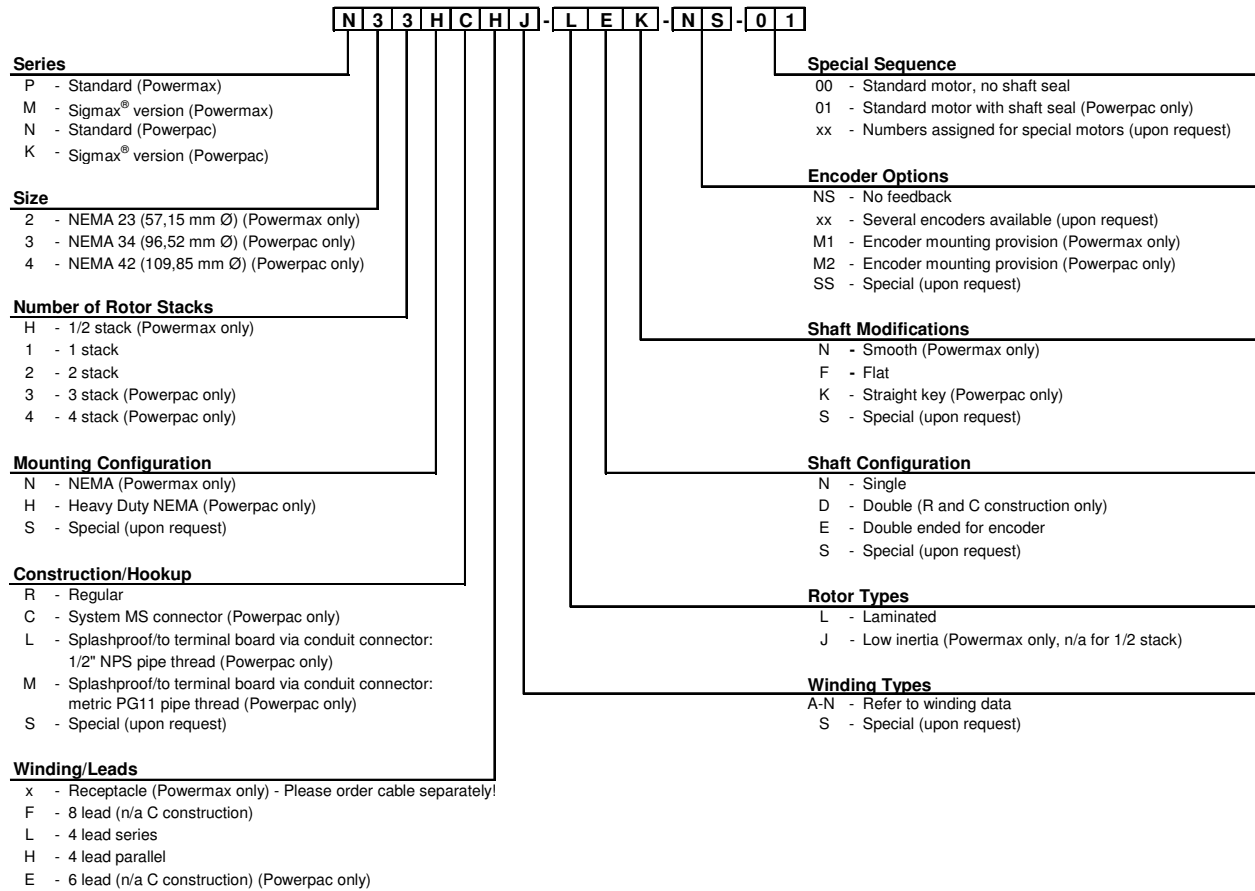

## 2. Technical Data

### 2.1. Powermax II® Series P and M

#### 2.1.1. Data P Series (Standard), NEMA 23

<b>P2HNRXx-LNN-NS-00*</b>			<b>F</b>	<b>C</b>	<b>H</b>
<i>Motor Data</i>					
<b>Holding Torque</b> (bipolar/parallel 2 phases on)	<b>M<sub>H</sub></b>	<b>Nm</b>	<b>0,42</b>	<b>0,43</b>	<b>0,42</b>
<b>Rated current per winding</b> (bipolar, parallel)	<b>I</b>	<b>A</b>	<b>1,6</b>	<b>2,5</b>	<b>5,2</b>
<i>Technical Data</i>					
Full Step			200 per revolution		
Step angle		°	1,8	1,8	1,8
Angular accuracy		%	3	3	3
Phases			2	2	2
Winding resistance	R <sub>ph</sub>	Ω	3,8	1,68	0,44
Winding inductance	L <sub>ph</sub>	mH	5,1	2,3	0,5
Detent torque	M <sub>P</sub>	Nm	0,018	0,018	0,018
Insulation class			B	B	B
Insulation inductance			100MΩ @ 500V <sub>DC</sub>		
Dielectricity test			500V <sub>DC</sub> 1min		
<i>Mechanical Data</i>					
Rotor inertia	J	Kgm <sup>2</sup> *10 <sup>-3</sup>	0,007	0,007	0,007
Mass	m	kg	0,45	0,45	0,45
Length	L <sub>max</sub>	mm	40,7	40,7	40,7
Ambient temperature		°C	-20 to +40		
max. surface temperature		°C	95		
Protection class			IP 23		

\* Please replace the x in the item number with the letter of the requested winding.

<b>P21NRXx-LNN-NS-00*</b>			<b>D</b>	<b>C</b>	<b>B</b>	<b>A</b>
<i>Motor Data</i>						
<b>Holding Torque</b> (bipolar/parallel 2 phases on)	<b>M<sub>H</sub></b>	<b>Nm</b>	<b>0,77</b>	<b>0,82</b>	<b>0,79</b>	<b>0,81</b>
<b>Rated current per winding</b> (bipolar, parallel)	<b>I</b>	<b>A</b>	<b>1,5</b>	<b>3,5</b>	<b>4,6</b>	<b>5,6</b>
<i>Technical Data</i>						
Full step			200 per revolution			
Step angle		°	1,8	1,8	1,8	1,8
Angular accuracy		%	3	3	3	3
Phases			2	2	2	2
Winding resistance	R <sub>ph</sub>	Ω	5,22	1,06	0,64	0,46
Winding inductivity	L <sub>ph</sub>	mH	10,3	2,3	1,1	0,8
Detent torque	M <sub>P</sub>	Nm	0,03	0,03	0,03	0,03
Insulation class			B	B	B	B
Insulation inductance			100MΩ @ 500V <sub>DC</sub>			
Dielectricity test			500V <sub>DC</sub> 1min			
<i>Mechanical Data</i>						
Rotor inertia	J	Kgm <sup>2</sup> *10 <sup>-3</sup>	0,012	0,012	0,012	0,012
Mass	m	kg	0,68	0,68	0,68	0,68
Length	L <sub>max</sub>	mm	52,4	52,4	52,4	52,4
Ambient temperature		°C	-20 to +40			
max. surface temperature		°C	95			
Protection class			IP 23			

\* Please replace the x in the item number with the letter of the requested winding.

<b>P22NRXx-LNN-NS-00*</b>			<b>D</b>	<b>C</b>	<b>B</b>	<b>A</b>
<i>Motor Data</i>						
<b>Holding Torque</b> (bipolar/parallel 2 phases on)	<b>M<sub>H</sub></b>	<b>Nm</b>	<b>1,43</b>	<b>1,43</b>	<b>1,51</b>	<b>1,39</b>
<b>Rated current per winding</b> (bipolar, parallel)	<b>I</b>	<b>A</b>	<b>2,5</b>	<b>3,1</b>	<b>4,6</b>	<b>6,5</b>
<i>Technical Data</i>						
Full step				200 per revolution		
Step angle		°	1,8	1,8	1,8	1,8
Angular accuracy		%	3	3	3	3
Phases			2	2	2	2
Winding resistance	R <sub>ph</sub>	Ω	2,44	1,56	0,76	0,42
Winding inductivity	L <sub>ph</sub>	mH	6,2	3,9	2,1	0,8
Detent torque	M <sub>P</sub>	Nm	0,05	0,05	0,05	0,05
Insulation class			B	B	B	B
Insulation inductance				100MΩ @ 500V <sub>DC</sub>		
Dielectricity test				500V <sub>DC</sub> 1min		
<i>Mechanical Data</i>						
Rotor inertia	J	Kgm <sup>2</sup> *10 <sup>-3</sup>	0,025	0,025	0,025	0,025
Mass	m	kg	1,13	1,13	1,13	1,13
Length	L <sub>max</sub>	mm	78,8	78,8	78,8	78,8
Ambient temperature		°C		-20 to +40		
max. surface temperature		°C		95		
Protection class				IP 23		

\* Please replace the x in the item number with the letter of the requested winding.

### 2.1.2. Data M Series (Sigmax®), NEMA 23

<b>M21NRXx-LNN-NS-00*</b>			<b>D</b>	<b>C</b>	<b>B</b>	<b>A</b>
<i>Motor Data</i>						
<b>Holding Torque</b> (bipolar/parallel 2 phases on)	<b>M<sub>H</sub></b>	<b>Nm</b>	<b>0,95</b>	<b>1,02</b>	<b>0,97</b>	<b>1,00</b>
<b>Rated current per winding</b> (bipolar, parallel)	<b>I</b>	<b>A</b>	<b>1,5</b>	<b>3,5</b>	<b>4,6</b>	<b>5,6</b>
<i>Technical Data</i>						
Full step				200 per revolution		
Step angle		°	1,8	1,8	1,8	1,8
Angular accuracy		%	1,5	1,5	1,5	1,5
Phases			2	2	2	2
Winding resistance	R <sub>ph</sub>	Ω	5,22	1,06	0,64	0,46
Winding inductivity	L <sub>ph</sub>	mH	8,7	2,0	1,0	0,7
Detent torque	M <sub>P</sub>	Nm	0,066	0,066	0,066	0,066
Insulation class			B	B	B	B
Insulation inductance				100MΩ @ 500V <sub>DC</sub>		
Dielectricity test				500V <sub>DC</sub> 1min		
<i>Mechanical Data</i>						
Rotor inertia	J	Kgm <sup>2</sup> *10 <sup>-3</sup>	0,012	0,012	0,012	0,012
Mass	m	kg	0,68	0,68	0,68	0,68
Length	L <sub>max</sub>	mm	52,4	52,4	52,4	52,4
Ambient temperature		°C		-20 to +40		
max. surface temperature		°C		95		
Protection class				IP 23		

\* Please replace the x in the item number with the letter of the requested winding.

**M22NRXx-LNN-NS-00\***

			<b>D</b>	<b>C</b>	<b>B</b>	<b>A</b>
<i>Motor Data</i>						
<b>Holding Torque</b> (bipolar/parallel 2 phases on)	<b>M<sub>H</sub></b>	<b>Nm</b>	<b>1,68</b>	<b>1,68</b>	<b>1,79</b>	<b>1,62</b>
<b>Rated current per winding</b> (bipolar, parallel)	<b>I</b>	<b>A</b>	<b>2,5</b>	<b>3,1</b>	<b>4,6</b>	<b>6,5</b>
<i>Technical Data</i>						
Full step			200 per revolution			
Step angle		°	1,8	1,8	1,8	1,8
Angular accuracy		%	1,5	1,5	1,5	1,5
Phases			2	2	2	2
Winding resistance	R <sub>ph</sub>	Ω	2,44	1,56	0,76	0,42
Winding inductivity	L <sub>ph</sub>	mH	5,0	3,1	1,7	0,7
Detent torque	M <sub>P</sub>	Nm	0,12	0,12	0,12	0,12
Insulation class			B	B	B	B
Insulation inductance			100MΩ @ 500V <sub>DC</sub>			
Dielectricity test			500V <sub>DC</sub> 1min			
<i>Mechanical Data</i>						
Rotor inertia	J	Kgm <sup>2</sup> *10 <sup>-3</sup>	0,025	0,025	0,025	0,025
Mass	m	kg	1,13	1,13	1,13	1,13
Length	L <sub>max</sub>	mm	78,8	78,8	78,8	78,8
Ambient temperature		°C	-20 to +40			
max. surface temperature		°C	95			
Protection class			IP 23			

\* Please replace the x in the item number with the letter of the requested winding.

**2.1.3. Torque Characteristics POWERMAX II®**

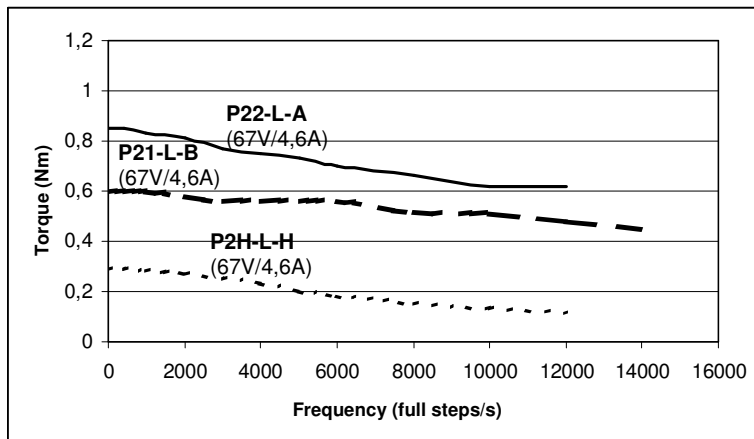

**P Series**  
selected windings -  
connection bipolar, parallel,  
with drive DSM5-70

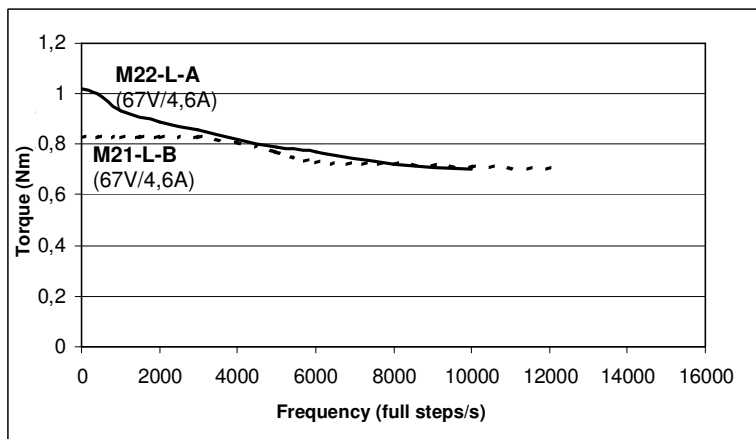

**M Series**  
selected windings -  
connection bipolar, parallel,  
with drive DSM5-70

2.1.4. Dimensions POWERMAX II® Series P and M

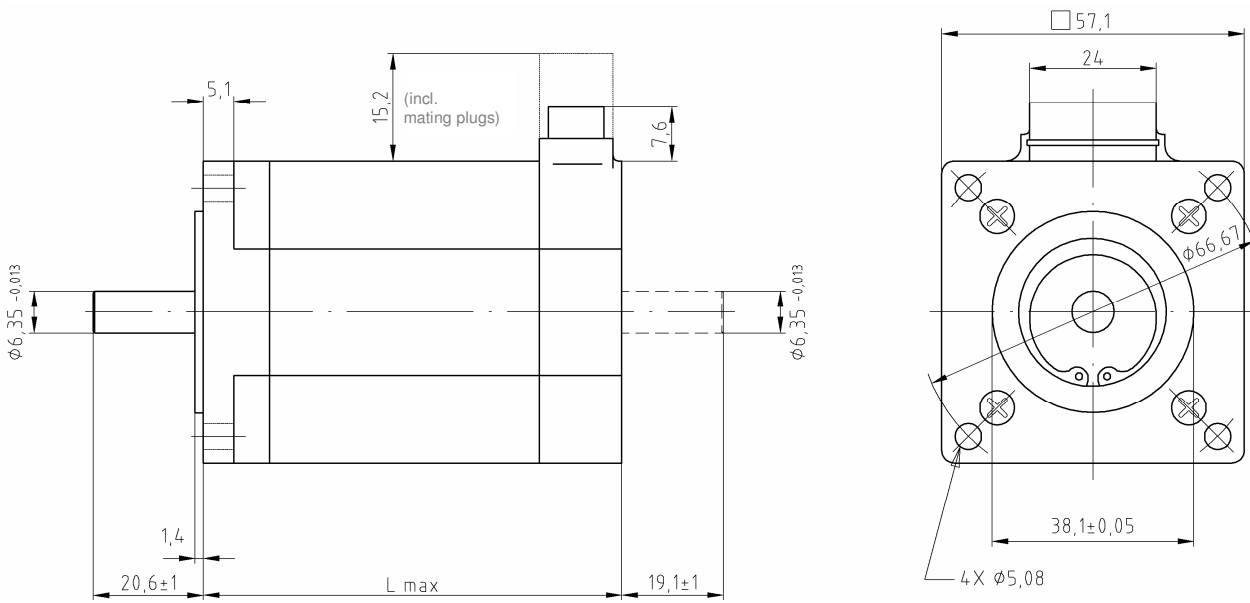

all dimensions in mm

Motor type	P2H	P21/M21	P22/M22
Length	40,7	52,4	78,8

**Note!**

The 8core cable of 300mm length which is need for the Powermax motors has to be ordered separately (order no. KAB.300).

## 2.2. POWERPAC™ Series N and K

### 2.2.1. Data N Series (Standard), NEMA 34

N31HRFy-LNK-NS-00*			H	J	K	L
<i>Motor Data</i>						
<b>Holding Torque</b> (bipolar/parallel 2 phases on)	<b>M<sub>H</sub></b>	<b>Nm</b>	<b>4,5</b>	<b>4,5</b>	<b>4,7</b>	<b>4,6</b>
<b>Rated current per winding</b> (bipolar, parallel)	<b>I</b>	<b>A</b>	<b>2,8</b>	<b>5,5</b>	<b>6,6</b>	<b>8,6</b>
<i>Technical Data</i>						
Full step				200 per revolution		
Step angle		°	1,8	1,8	1,8	1,8
Angular accuracy		%	3	3	3	3
Phases			2	2	2	2
Winding resistance	R <sub>ph</sub>	Ω	3,1	0,84	0,58	0,36
Winding inductivity	L <sub>ph</sub>	mH	12,5	3,5	2,6	1,4
Detent torque	M <sub>P</sub>	Nm	0,13	0,13	0,13	0,13
Insulation class			B	B	B	B
Insulation inductance				100MΩ @ 500V <sub>DC</sub>		
Dielectricity test				500V <sub>DC</sub> 1min		
<i>Mechanical Data</i>						
Rotor inertia	J	Kgm <sup>2</sup> *10 <sup>-3</sup>	0,14	0,14	0,14	0,14
Mass	m	kg	2,3	2,3	2,3	2,3
Length	L	mm	112,8	112,8	112,8	112,8
Ambient temperature		°C		-20 to +40		
max. surface temperature		°C		95		
Protection class				IP 44		

\* Please replace the y in the item number with the letter of the requested winding.

N32HRFy-LNK-NS-00*			J	K	L	M
<i>Motor Data</i>						
<b>Holding Torque</b> (bipolar/parallel 2 phases on)	<b>M<sub>H</sub></b>	<b>Nm</b>	<b>8,4</b>	<b>8,8</b>	<b>8,5</b>	<b>8,6</b>
<b>Rated current per winding</b> (bipolar, parallel)	<b>I</b>	<b>A</b>	<b>5,1</b>	<b>6,1</b>	<b>8,1</b>	<b>10,0</b>
<i>Technical Data</i>						
Full step				200 per revolution		
Step angle		°	1,8	1,8	1,8	1,8
Angular accuracy		%	3	3	3	3
Phases			2	2	2	2
Winding resistance	R <sub>ph</sub>	Ω	1,27	0,9	0,52	0,35
Winding inductivity	L <sub>ph</sub>	mH	6,5	5,1	2,6	1,8
Detent torque	M <sub>P</sub>	Nm	0,25	0,25	0,25	0,25
Insulation class			B	B	B	B
Insulation inductance				100MΩ @ 500V <sub>DC</sub>		
Dielectricity test				500V <sub>DC</sub> 1min		
<i>Mechanical Data</i>						
Rotor inertia	J	Kgm <sup>2</sup> *10 <sup>-3</sup>	0,27	0,27	0,27	0,27
Mass	m	kg	3,8	3,8	3,8	3,8
Length	L	mm	151,4	151,4	151,4	151,4
Ambient temperature		°C		-20 to +40		
max. surface temperature		°C		95		
Protection class				IP 44		

\* Please replace the y in the item number with the letter of the requested winding.

<b>N33HRFy-LNK-NS-00*</b>			<b>J</b>	<b>K</b>	<b>L</b>	<b>M</b>
<i>Motor Data</i>						
<b>Holding Torque</b> (bipolar/parallel 2 phases on)	<b>M<sub>H</sub></b>	<b>Nm</b>	12,1	12,4	13,0	12,1
<b>Rated current per winding</b> (bipolar, parallel)	<b>I</b>	<b>A</b>	5,0	6,1	9,0	9,9
<i>Technical Data</i>						
Full step				200 per revolution		
Step angle		°	1,8	1,8	1,8	1,8
Angular accuracy		%	3	3	3	3
Phases			2	2	2	2
Winding resistance	R <sub>ph</sub>	Ω	1,65	1,12	0,53	0,44
Winding inductivity	L <sub>ph</sub>	mH	9,0	6,4	3,4	2,3
Detent torque	M <sub>P</sub>	Nm	0,38	0,38	0,38	0,38
Insulation class			B	B	B	B
Insulation inductance				100MΩ @ 500V <sub>DC</sub>		
Dielectricity test				500V <sub>DC</sub> 1min		
<i>Mechanical Data</i>						
Rotor inertia	J	Kgm <sup>2</sup> *10 <sup>-3</sup>	0,4	0,4	0,4	0,4
Mass	m	kg	5,4	5,4	5,4	5,4
Length	L	mm	155,7	155,7	155,7	155,7
Ambient temperature		°C		-20 to +40		
max. surface temperature		°C		95		
Protection class				IP 44		

\* Please replace the y in the item number with the letter of the requested winding.

<b>N34HRFy-LNK-NS-00*</b>			<b>J</b>	<b>K</b>	<b>L</b>	<b>M</b>
<i>Motor Data</i>						
<b>Holding Torque</b> (bipolar/parallel 2 phases on)	<b>M<sub>H</sub></b>	<b>Nm</b>	15,3	14,36	15,4	15,1
<b>Rated current per winding</b> (bipolar, parallel)	<b>I</b>	<b>A</b>	5,5	6,0	8,7	11,3
<i>Technical Data</i>						
Full step				200 per revolution		
Step angle		°	1,8	1,8	1,8	1,8
Angular accuracy		%	3	3	3	3
Phases			2	2	2	2
Winding resistance	R <sub>ph</sub>	Ω	1,6	1,35	0,66	0,41
Winding inductivity	L <sub>ph</sub>	mH	11,5	8,1	4,7	2,6
Detent torque	M <sub>P</sub>	Nm	0,4	0,4	0,4	0,4
Insulation class			B	B	B	B
Insulation inductance				100MΩ @ 500V <sub>DC</sub>		
Dielectricity test				500V <sub>DC</sub> 1min		
<i>Mechanical Data</i>						
Rotor inertia	J	Kgm <sup>2</sup> *10 <sup>-3</sup>	0,53	0,53	0,53	0,53
Mass	m	kg	6,8	6,8	6,8	6,8
Length	L	mm	195,1	195,1	195,1	195,1
Ambient temperature		°C		-20 to +40		
max. surface temperature		°C		95		
Protection class				IP 44		

\* Please replace the y in the item number with the letter of the requested winding.

## 2.2.2. Data K Series (Sigmax®), NEMA 34

<b>K31HRFy-LNK-NS-00*</b>			<b>H</b>	<b>J</b>	<b>K</b>	<b>L</b>	<b>P</b>
<i>Motor Data</i>							
<b>Holding Torque</b> (bipolar/parallel 2 phases on)	<b>M<sub>H</sub></b>	<b>Nm</b>	<b>5,7</b>	<b>5,8</b>	<b>6,0</b>	<b>5,9</b>	<b>5,9</b>
<b>Rated current per winding</b> (bipolar, parallel)	<b>I</b>	<b>A</b>	<b>2,8</b>	<b>5,5</b>	<b>6,6</b>	<b>8,6</b>	<b>2,8</b>
Rated voltage	U <sub>DC</sub>	V	170	170	170	170	325
<i>Technical Data</i>							
Full step					200		
Step angle		°	1,8	1,8	1,8	1,8	1,8
Angular accuracy		%	1,5	1,5	1,5	1,5	1,5
Phases			2	2	2	2	2
Winding resistance	R <sub>ph</sub>	Ω	3,1	0,84	0,58	0,36	1,55
Winding inductivity	L <sub>ph</sub>	mH	10,2	2,8	2,1	1,2	10,2
Detent torque	M <sub>P</sub>	Nm	0,18	0,18	0,18	0,18	0,18
Insulation class			B	B	B	B	B
Insulation inductance					100MΩ @ 500V <sub>DC</sub>		
Dielectricity test					500V <sub>DC</sub> 1min		
<i>Mechanical Data</i>							
Rotor inertia	J	Kgm <sup>2</sup> *10 <sup>-3</sup>	0,14	0,14	0,14	0,14	0,14
Mass	m	kg	2,3	2,3	2,3	2,3	2,3
Length	L	mm	112,8	112,8	112,8	112,8	112,8
Ambient temperature		°C			-20 to +40		
max. surface temperature		°C			95		
Protection class					IP 44		

\* Please replace the y in the item number with the letter of the requested winding.

<b>K32HRFy-LNK-NS-00*</b>			<b>J</b>	<b>K</b>	<b>L</b>	<b>M</b>	<b>P</b>
<i>Motor Data</i>							
<b>Holding Torque</b> (bipolar/parallel 2 phases on)	<b>M<sub>H</sub></b>	<b>Nm</b>	<b>10,7</b>	<b>11,15</b>	<b>10,7</b>	<b>10,8</b>	<b>10,7</b>
<b>Rated current per winding</b> (bipolar, parallel)	<b>I</b>	<b>A</b>	<b>5,1</b>	<b>6,1</b>	<b>8,1</b>	<b>10,0</b>	<b>3,3</b>
Rated voltage	U <sub>DC</sub>	V	170	170	170	170	325
<i>Technical Data</i>							
Full step							
Step angle		°	1,8	1,8	1,8	1,8	1,8
Angular accuracy		%	1,5	1,5	1,5	1,5	1,5
Phases			2	2	2	2	2
Winding resistance	R <sub>ph</sub>	Ω	1,27	0,9	0,52	0,35	1,5
Winding inductivity	L <sub>ph</sub>	mH	5,1	4,0	2,0	1,4	11,8
Detent torque	M <sub>P</sub>	Nm	0,35	0,35	0,35	0,35	0,35
Insulation class			B	B	B	B	B
Insulation inductance					100MΩ @ 500V <sub>DC</sub>		
Dielectricity test					500V <sub>DC</sub> 1min		
<i>Mechanical Data</i>							
Rotor inertia	J	Kgm <sup>2</sup> *10 <sup>-3</sup>	0,27	0,27	0,27	0,27	0,27
Mass	m	kg	3,8	3,8	3,8	3,8	3,8
Length	L	mm	151,4	151,4	151,4	151,4	151,4
Ambient temperature		°C			-20 to +40		
max. surface temperature		°C			95		
Protection class					IP 44		

\* Please replace the y in the item number with the letter of the requested winding.

<b>K33HRFy-LNK-NS-00*</b>			<b>J</b>	<b>K</b>	<b>L</b>	<b>M</b>	<b>P</b>
<i>Motor Data</i>							
<b>Holding Torque</b> (bipolar/parallel 2 phases on)	M <sub>H</sub>	Nm	<b>15,1</b>	<b>15,6</b>	<b>16,5</b>	<b>15,2</b>	<b>15,1</b>
<b>Rated current per winding</b> (bipolar, parallel)	I	A	<b>5,0</b>	<b>6,1</b>	<b>9,0</b>	<b>9,9</b>	<b>3,7</b>
Rated voltage	U <sub>DC</sub>	V	170	170	170	170	325
<i>Technical Data</i>							
Full step							
Step angle		°	1,8	1,8	1,8	1,8	1,8
Angular accuracy		%	1,5	1,5	1,5	1,5	1,5
Phases			2	2	2	2	2
Winding resistance	R <sub>ph</sub>	Ω	1,65	1,12	0,53	0,44	1,5
Winding inductivity	L <sub>ph</sub>	mH	7,0	5,0	2,6	1,2	14,9
Detent torque	M <sub>P</sub>	Nm	0,53	0,53	0,53	0,53	0,53
Insulation class			B	B	B	B	B
Insulation inductance					100MΩ @ 500V <sub>DC</sub>		
Dielectricity test					500V <sub>DC</sub> 1min		
<i>Mechanical Data</i>							
Rotor inertia	J	Kgm <sup>2</sup> ·10 <sup>-3</sup>	0,4	0,4	0,4	0,4	0,4
Mass	m	kg	5,4	5,4	5,4	5,4	5,4
Length	L	mm	155,7	155,7	155,7	155,7	155,7
Ambient temperature		°C			-20 to +40		
max. surface temperature		°C			95		
Protection class					IP 44		

\* Please replace the y in the item number with the letter of the requested winding.

<b>K34HRFy-LNK-NS-00*</b>			<b>J</b>	<b>K</b>	<b>L</b>	<b>M</b>	<b>P</b>
<i>Motor Data</i>							
<b>Holding Torque</b> (bipolar/parallel 2 phases on)	M <sub>H</sub>	Nm	<b>19,6</b>	<b>18,2</b>	<b>19,7</b>	<b>19,2</b>	<b>19,2</b>
<b>Rated current per winding</b> (bipolar, parallel)	I	A	<b>5,5</b>	<b>6,0</b>	<b>8,7</b>	<b>11,3</b>	<b>3,7</b>
Rated voltage	U <sub>DC</sub>	V	170	170	170	170	325
<i>Technical Data</i>							
Full step							
Step angle		°	1,8	1,8	1,8	1,8	1,8
Angular accuracy		%	1,5	1,5	1,5	1,5	1,5
Phases			2	2	2	2	2
Winding resistance	R <sub>ph</sub>	Ω	1,6	1,35	0,66	0,41	1,8
Winding inductivity	L <sub>ph</sub>	mH	8,9	6,3	3,6	2,0	18,4
Detent torque	M <sub>P</sub>	Nm	0,5	0,5	0,5	0,5	0,5
Insulation class			B	B	B	B	B
Insulation inductance					100MΩ @ 500V <sub>DC</sub>		
Dielectricity test					500V <sub>DC</sub> 1min		
<i>Mechanical Data</i>							
Rotor inertia	J	Kgm <sup>2</sup> ·10 <sup>-3</sup>	0,53	0,53	0,53	0,53	0,53
Mass	m	kg	6,8	6,8	6,8	6,8	6,8
Length	L	mm	195,1	195,1	195,1	195,1	195,1
Ambient temperature		°C			-20 to +40		
max. surface temperature		°C			95		
Protection class					IP 44		

\* Please replace the y in the item number with the letter of the requested winding.

### 2.2.3. Data N Series (Standard), NEMA 42

#### N41HRFy-LNK-NS-00\*

			J	L	M
<i>Motor Data</i>					
<b>Holding Torque</b> (bipolar/parallel 2 phases on)	<b>M<sub>H</sub></b>	<b>Nm</b>	11,5	11,5	11,7
<b>Rated current per winding</b> (bipolar, parallel)	<b>I</b>	<b>A</b>	5,5	8,7	10,7
<i>Technical Data</i>					
Full step				200 per revolution	
Step angle		°	1,8	1,8	1,8
Angular accuracy		%	3	3	3
Phases			2	2	2
Winding resistance	R <sub>ph</sub>	Ω	1,16	0,47	0,31
Winding inductivity	L <sub>ph</sub>	mH	10,1	3,9	2,8
Detent torque	M <sub>P</sub>	Nm	0,3	0,3	0,3
Insulation class			B	B	B
Insulation inductance				100MΩ @ 500V <sub>DC</sub>	
Dielectricity test				500V <sub>DC</sub> 1min	
<i>Mechanical Data</i>					
Rotor inertia	J	Kgm <sup>2</sup> *10 <sup>-3</sup>	0,55	0,55	0,55
Mass	m	kg	5,0	5,0	5,0
Length	L	mm	132,1	132,1	132,1
Ambient temperature		°C		-20 to +40	
max. surface temperature		°C		95	
Protection class				IP 44	

\* Please replace the y in the item number with the letter of the requested winding.

#### N42HRFy-LNK-NS-00\*

			K	L	M	N
<i>Motor Data</i>						
<b>Holding Torque</b> (bipolar/parallel 2 phases on)	<b>M<sub>H</sub></b>	<b>Nm</b>	21,9	21,8	22,2	22,1
<b>Rated current per winding</b> (bipolar, parallel)	<b>I</b>	<b>A</b>	6,4	8,1	9,9	15,8
<i>Technical Data</i>						
Full step				200 per revolution		
Step angle		°	1,8	1,8	1,8	1,8
Angular accuracy		%	3	3	3	3
Phases			2	2	2	2
Winding resistance	R <sub>ph</sub>	Ω	1,2	0,75	0,51	0,21
Winding inductivity	L <sub>ph</sub>	mH	12,8	7,8	5,5	2,1
Detent torque	M <sub>P</sub>	Nm	0,59	0,59	0,59	0,59
Insulation class			B	B	B	B
Insulation inductance				100MΩ @ 500V <sub>DC</sub>		
Dielectricity test				500V <sub>DC</sub> 1min		
<i>Mechanical Data</i>						
Rotor inertia	J	Kgm <sup>2</sup> *10 <sup>-3</sup>	1,09	1,09	1,09	1,09
Mass	m	kg	8,3	8,3	8,3	8,3
Length	L	mm	183,4	183,4	183,4	183,4
Ambient temperature		°C		-20 to +40		
max. surface temperature		°C		95		
Protection class				IP 44		

\* Please replace the y in the item number with the letter of the requested winding.

<b>N43HRFy-LNK-NS-00*</b>			<b>K</b>	<b>L</b>	<b>M</b>	<b>N</b>
<i>Motor Data</i>						
<b>Holding Torque</b> (bipolar/parallel 2 phases on)	<b>M<sub>H</sub></b>	<b>Nm</b>	30,6	30,0	30,5	30,8
<b>Rated current per winding</b> (bipolar, parallel)	<b>I</b>	<b>A</b>	6,2	8,0	9,9	15,4
<i>Technical Data</i>						
Full step				200 per revolution		
Step angle		°	1,8	1,8	1,8	1,8
Angular accuracy		%	3	3	3	3
Phases			2	2	2	2
Winding resistance	R <sub>ph</sub>	Ω	1,65	0,99	0,66	0,28
Winding inductivity	L <sub>ph</sub>	mH	19,6	11,0	7,7	3,2
Detent torque	M <sub>P</sub>	Nm	0,75	0,75	0,75	0,75
Insulation class			B	B	B	B
Insulation inductance				100MΩ @ 500V <sub>DC</sub>		
Dielectricity test				500V <sub>DC</sub> 1min		
<i>Mechanical Data</i>						
Rotor inertia	J	Kgm <sup>2</sup> *10 <sup>-3</sup>	1,62	1,62	1,62	1,62
Mass	m	kg	11,6	11,6	11,6	11,6
Length	L	mm	234,4	234,4	234,4	234,4
Ambient temperature		°C		-20 to +40		
max. surface temperature		°C		95		
Protection class				IP 44		

\* Please replace the y in the item number with the letter of the requested winding.

### 2.2.4. Data K Series (SIGMAX®) - NEMA 42

<b>K41HRFy-LNK-NS-00*</b>			<b>J</b>	<b>L</b>	<b>M</b>	<b>P</b>
<i>Motor Data</i>						
<b>Holding Torque</b> (bipolar/parallel 2 phases on)	<b>M<sub>H</sub></b>	<b>Nm</b>	<b>14,8</b>	<b>14,8</b>	<b>15,1</b>	<b>15,0</b>
<b>Rated current per winding</b> (bipolar, parallel)	<b>I</b>	<b>A</b>	<b>5,5</b>	<b>8,7</b>	<b>10,7</b>	<b>3,4</b>
Rated voltage	U <sub>DC</sub>	V	170	170	170	325
<i>Technical Data</i>						
Full step						
Step angle		°	1,8	1,8	1,8	1,8
Angular accuracy		%	1,5	1,5	1,5	1,5
Phases			2	2	2	2
Winding resistance	R <sub>ph</sub>	Ω	1,16	0,47	0,31	1,47
Winding inductivity	L <sub>ph</sub>	mH	7,8	3,1	2,2	20,1
Detent torque	M <sub>P</sub>	Nm	0,46	0,46	0,46	0,46
Insulation class			B	B	B	B
Insulation inductance				100MΩ @ 500V <sub>DC</sub>		
Dielectricity test				500V <sub>DC</sub> 1min		
<i>Mechanical Data</i>						
Rotor inertia	J	Kgm <sup>2</sup> *10 <sup>-3</sup>	0,55	0,55	0,55	0,55
Mass	m	kg	5,0	5,0	5,0	5,0
Length	L	mm	132,1	132,1	132,1	132,1
Ambient temperature		°C		-20 to +40		
max. surface temperature		°C		95		
Protection class				IP 44		

\* Please replace the y in the item number with the letter of the requested winding.

<b>K42HRFy-LNK-NS-00*</b>			<b>K</b>	<b>L</b>	<b>M</b>	<b>N</b>	<b>P</b>	
<i>Motor Data</i>								
<b>Holding Torque</b> (bipolar/parallel 2 phases on)	<b>M<sub>H</sub></b>	<b>Nm</b>	<b>28,0</b>	<b>27,8</b>	<b>28,4</b>	<b>28,2</b>	<b>28,1</b>	
<b>Rated current per winding</b> (bipolar, parallel)	<b>I</b>	<b>A</b>	<b>6,4</b>	<b>8,1</b>	<b>9,9</b>	<b>15,8</b>	<b>4,1</b>	
Rated voltage	U <sub>DC</sub>	V	170	170	170	170	325	
<i>Technical Data</i>								
Full step								
Step angle		°	1,8	1,8	1,8	1,8	1,8	
Angular accuracy		%	1,5	1,5	1,5	1,5	1,5	
Phases			2	2	2	2	2	
Winding resistance	R <sub>ph</sub>	Ω	1,2	0,75	0,51	0,21	1,47	
Winding inductivity	L <sub>ph</sub>	mH	9,8	6,0	4,2	1,6	23,0	
Detent torque	M <sub>P</sub>	Nm	0,69	0,69	0,69	0,69	0,69	
Insulation class			B	B	B	B	B	
Insulation inductance			100MΩ @ 500V <sub>DC</sub>					
Dielectricity test			500V <sub>DC</sub> 1min					
<i>Mechanical Data</i>								
Rotor inertia	J	Kgm <sup>2</sup> *10 <sup>-3</sup>	1,09	1,09	1,09	1,09	1,09	
Mass	m	kg	8,3	8,3	8,3	8,3	8,3	
Length	L	mm	183,4	183,4	183,4	183,4	183,4	
Ambient temperature		°C	-20 to +40					
max. surface temperature		°C	95					
Protection class			IP 44					

\* Please replace the y in the item number with the letter of the requested winding.

<b>K43HRFy-LNK-NS-00*</b>			<b>K</b>	<b>L</b>	<b>M</b>	<b>N</b>	<b>P</b>	
<i>Motor Data</i>								
<b>Holding Torque</b> (bipolar/parallel 2 phases on)	<b>M<sub>H</sub></b>	<b>Nm</b>	<b>39,9</b>	<b>39,0</b>	<b>39,7</b>	<b>40,23</b>	<b>40,1</b>	
<b>Rated current per winding</b> (bipolar, parallel)	<b>I</b>	<b>A</b>	<b>6,2</b>	<b>8,0</b>	<b>9,9</b>	<b>15,4</b>	<b>4,9</b>	
Rated voltage	U <sub>DC</sub>	V	170	170	170	170	325	
<i>Technical Data</i>								
Full step								
Step angle		°	1,8	1,8	1,8	1,8	1,8	
Angular accuracy		%	1,5	1,5	1,5	1,5	1,5	
Phases			2	2	2	2	2	
Winding resistance	R <sub>ph</sub>	Ω	1,65	0,99	0,66	0,28	1,33	
Winding inductivity	L <sub>ph</sub>	mH	15,2	8,5	5,9	2,5	24,9	
Detent torque	M <sub>P</sub>	Nm	0,83	0,83	0,83	0,83	0,83	
Insulation class			B	B	B	B	B	
Insulation inductance			100MΩ @ 500V <sub>DC</sub>					
Dielectricity test			500V <sub>DC</sub> 1min					
<i>Mechanical Data</i>								
Rotor inertia	J	Kgm <sup>2</sup> *10 <sup>-3</sup>	1,62	1,62	1,62	1,62	1,62	
Mass	m	kg	11,6	11,6	11,6	11,6	11,6	
Length	L	mm	234,4	234,4	234,4	234,4	234,4	
Ambient temperature		°C	-20 to +40					
max. surface temperature		°C	95					
Protection class			IP 44					

\* Please replace the y in the item number with the letter of the requested winding.

### 2.2.5. Torque Characteristics POWERPAC™

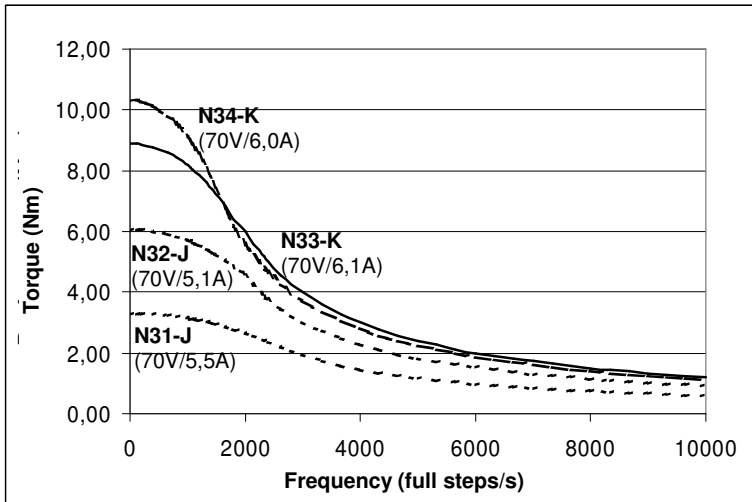

**Size N3 (Standard, NEMA 34)**  
 selected windings -  
 connection bipolar, parallel,  
 at 70V

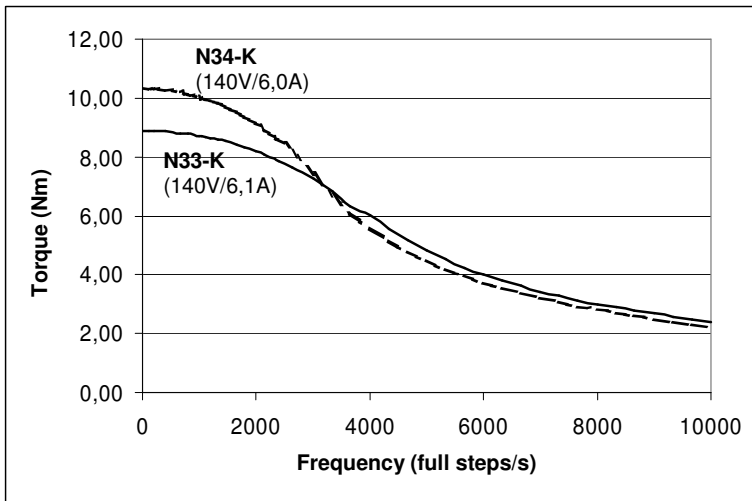

**Size N3 (Standard, NEMA 34)**  
 selected windings -  
 connection bipolar, parallel,  
 at 70V

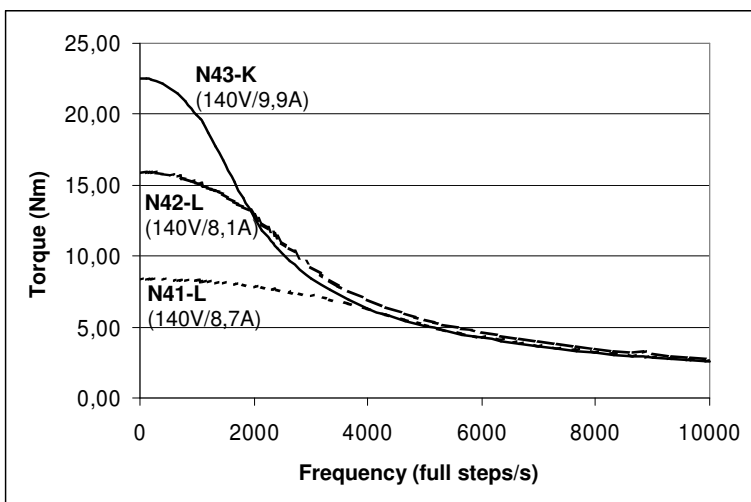

**Size N4 (Standard, NEMA 42)**  
 selected windings -  
 connection bipolar, parallel,  
 at 70V

**Note!**

Optimized characteristics for the K series motors for the requested phase currents and voltages are available upon request.

## 2.2.6. Dimensions POWERPAC™, NEMA 34

### Standard Version

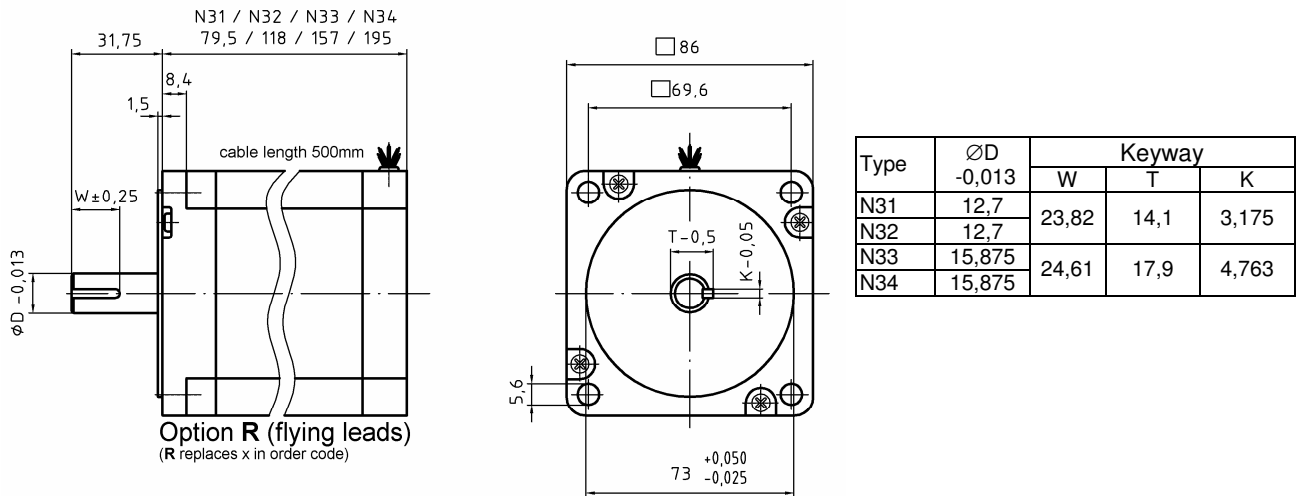

### Connector Options

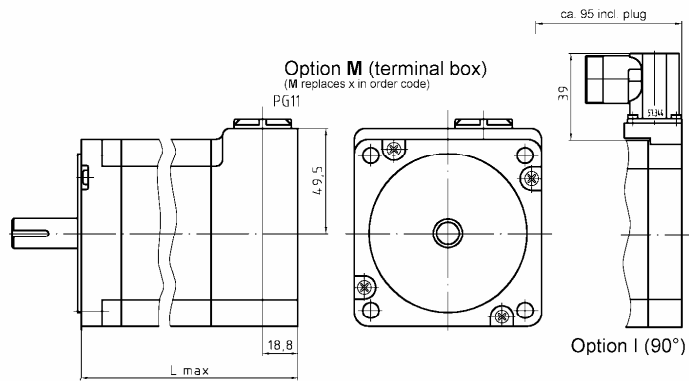

### Shaft Options

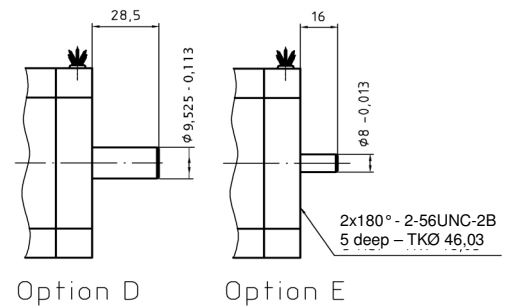

Type	N31	N32	N33	N34
L <sub>max</sub>	112,8	151,4	190,0	228,4

### Mounting Options

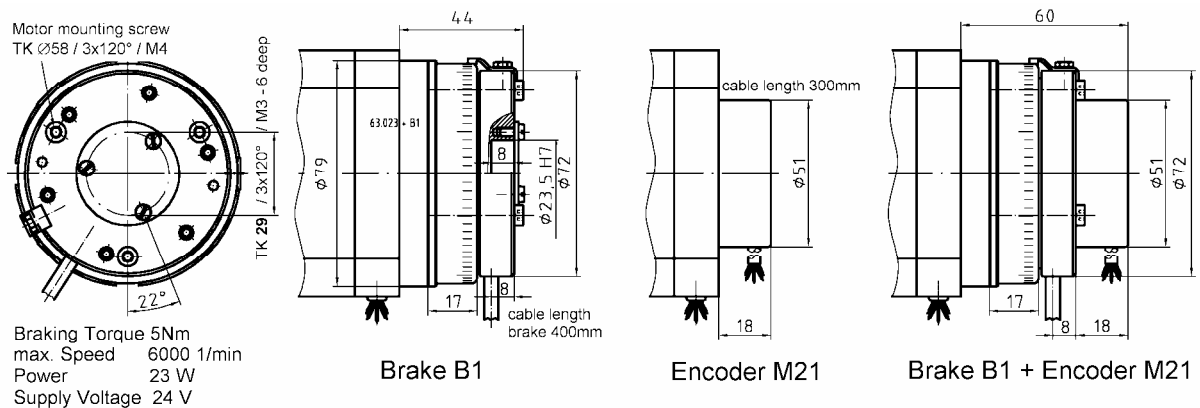

#### Note!

All dimensions in mm.

The above drawings only show the N series, but they are also valid for the K series.

### 2.2.7. Dimensions POWERPAC™, NEMA 42

#### Standard Version

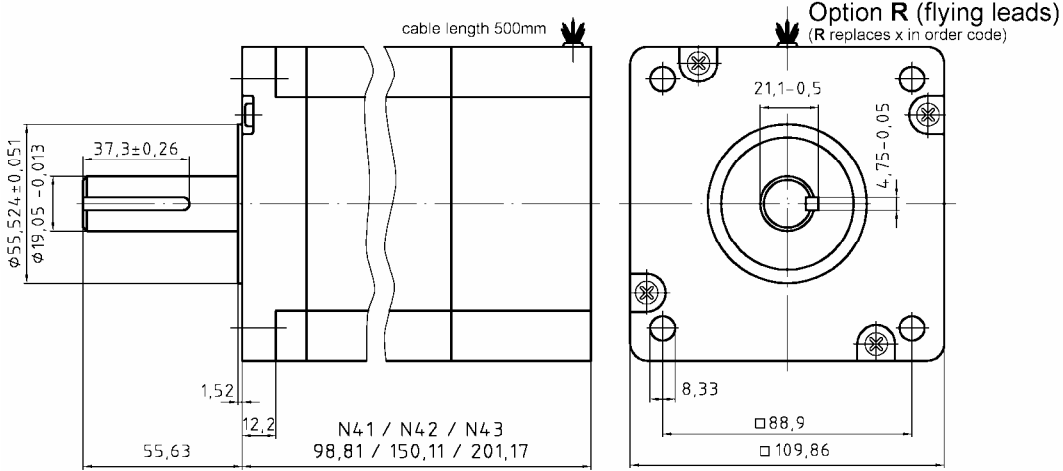

#### Connector Options

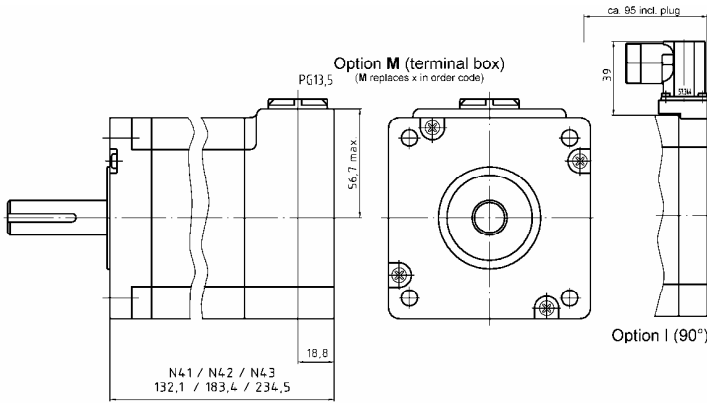

#### Shaft Options

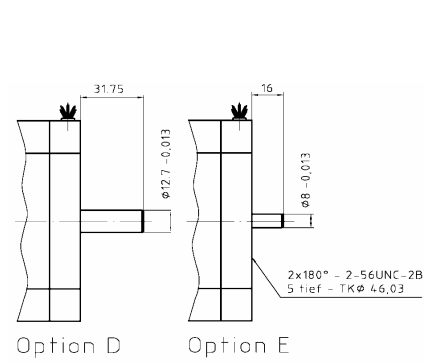

#### Mounting Options

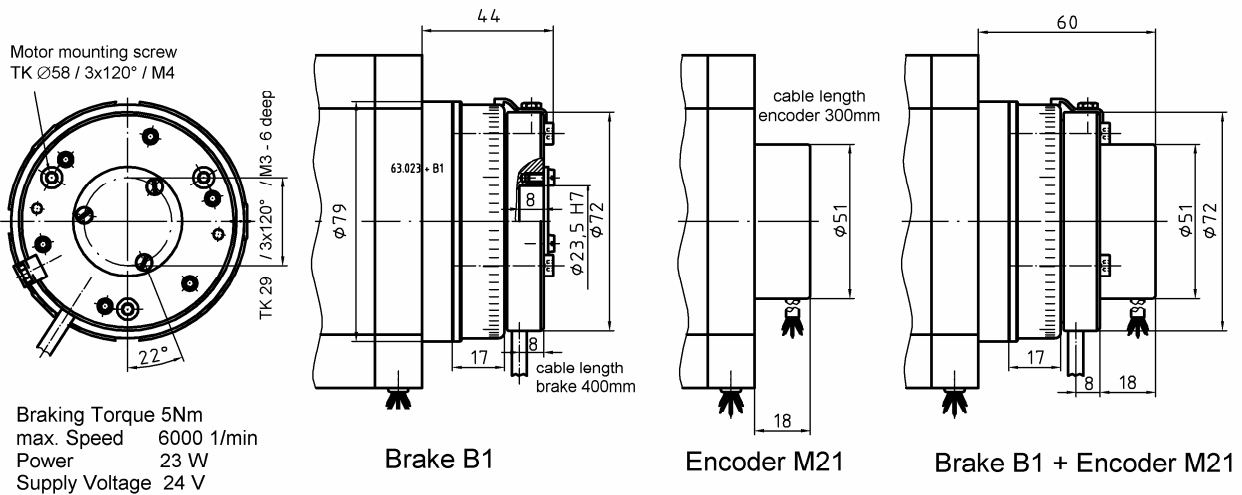

Braking Torque 5Nm  
 max. Speed 6000 1/min  
 Power 23 W  
 Supply Voltage 24 V

**Note!**

All dimensions in mm.  
 The above drawings only show the N series, but they are also valid for the K series.

### 3. Electrical Connections

#### 8 leads parallel

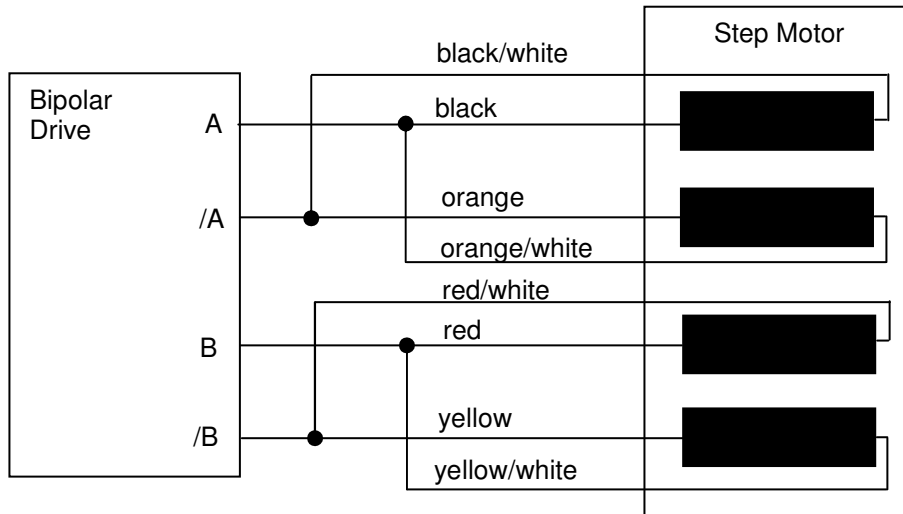

#### 8 leads serial



**Note!**

On 4-lead motors the connections are internally bridged and only the black, orange, red and yellow core are lead through.