

**NEW**

*Position-Based  
Synchronization  
Option*



## Electrak<sup>®</sup> HD

Linear Actuator with Onboard Controls, Superior Performance and Unmatched Environmental Protection



## Electrak<sup>®</sup> HD – Superior Performance Linear Actuator

Onboard electronics eliminate the need for standalone controls. Higher power opens a new, wider range of hydraulic applications to electric conversion. And it meets the most extreme OEM component environmental acceptance tests, including IP69K.

### Industry Leading, Onboard Electronics

The Electrak Modular Control System (EMCS) is the foundation for the best onboard controls currently available in electric linear actuators and includes optional, built-in CANopen<sup>®</sup> and SAE J1939 CAN bus support.

The feature-rich, modular design for all control and feedback options is simple to use and built within one compact housing. It improves controllability, saves space, and reduces installation time and total cost.

- A wide range of voltage options available, including 12, 24 and 48 Vdc
- Built-in CANopen and SAE J1939 CAN bus options enhance controllability, can eliminate individual controls, and simplify OEM machine design
- Electronic trip point calibration ensures consistent overload protection
- Constant monitoring of critical parameters such as end-of-stroke, voltage, current and temperature is standard on all HD actuators
- Built-in dynamic braking reduces coast at the end of stroke, improving repeatability
- Optional low-level switching with automatic sleep mode reduces footprint, lowers costs and boosts circuit isolation

- Optional end-of-stroke indication output for customer use, such as interlocks
- Optional synchronization feature allows for position-based motion integration of up to eight actuators.

### Superior Performance

Higher power and longer stroke lengths enable Electrak HD to tackle applications outside the range of traditional electric linear actuators.

- Higher load ranges up to 16 kN (3600 lbs.) are ideal for applications converting from hydraulic to electric actuators
- Stroke lengths up to 1 m (39 in.) for models up to 10 kN / 500 mm (20 in.) for 16 kN
- Efficient actuator design, including a high-quality ball screw, reduces current draw by up to 20%



### Unrivalled Environmental Protection

Electrak HD is tested to meet and exceed the toughest OEM mechanical and electronic component acceptance tests on the market today.

- IP69K (static), IP67 (static) and IP66 (dynamic) ratings prove Electrak HD can withstand the harshest environments
- Capable of operating in a wide temperature range from -40°C to +85°C (-40°F to +185°F)
- Salt spray tested for 500 hours
- CE, RoHS and REACH (EU) compliant
- Rated for IP-X6 (dynamic) during water splash at +10°C (+50°F) and an equalized actuator temperature of +85°C (+185°F)

### Additional Standard Features

- Integrated manual override
- Standard anti-rotation actuation
- Integrated thermal overload protection
- Load lock in case of ball nut overload failure
- Flexible front and rear clevis options





## How Thomson Built a World-Class Linear Actuator

1. Start with the proven, rugged Electrak® electric linear actuator.
2. Add state-of-the-art onboard controls, feedback, CANopen® or SAE J1939 CAN bus, and eliminate the need for standalone controls.
3. Boost the power, increase stroke lengths and reduce current draw.
4. Design it all into a more compact envelope with the best environmental protections on the market today.

### INDUSTRY-LEADING ONBOARD CONTROLS

The Electrak Modular Control System (EMCS) is the foundation of the best onboard controls available today for electric linear actuators and includes optional, built-in CANopen and SAE J1939 CAN bus support.

#### 1 EMCS

- Electronic Monitoring Package (standard)
- Synchronization Option
- End-of-Stroke Indication Output Option
- Analog Position Output Option
- Digital Position Output Option
- Low-Level Signal Motor Switching Option
- Programmable Limit Switches and Signal-Follower Option
- CANopen and SAE J1939 CAN Bus Control Options

#### 2 Built-in, End-of-Stroke Limit Switches

#### 3 Mounting Slots for External Limit Switches



## SUPERIOR PERFORMANCE

Higher power and longer stroke lengths enable Electrak HD to tackle applications outside the range of traditional electric linear actuators.

- 4 Modular Cabling
- 5 Standard Anti-Rotation Feature
- 6 Static Load Holding Brake
- 7 Robust Zinc Housing
- 8 Large Variety of Adapters
- 9 Integrated Manual Override
- 10 High-Efficiency Ball Screw Assembly

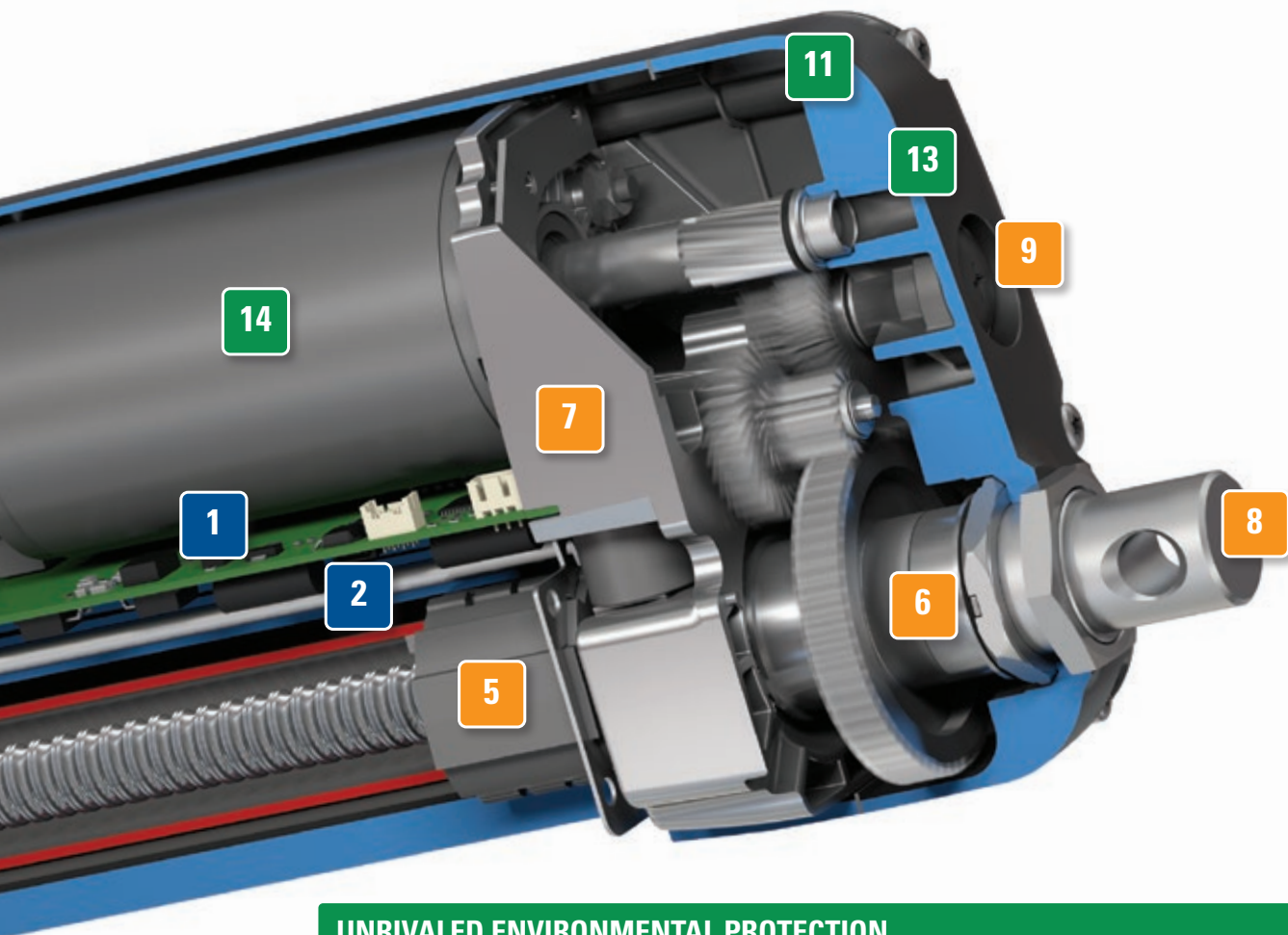

## UNRIVALED ENVIRONMENTAL PROTECTION

Electrak HD is tested to meet and exceed the toughest OEM mechanical and electronic component acceptance tests on the market today.

- 11 IP69K/IP67/IP66 Protection Class
- 12 Stainless Steel Extension Tube
- 13 Salt Spray Tested for 500 Hours
- 14 Large Operating Temperature Range
- 15 Hard-Coat Anodized Aluminum Cover Tube



## Smart Onboard Electronics for Easier Control

Thomson's Electrak Modular Control System (EMCS) is built into every Electrak® HD actuator and serves as the foundation for the best onboard controls currently available on the market, including optional CANopen® and SAE J1939 CAN bus.

### Industry Leading Onboard Electronics

EMCS is the culmination of decades of global design and application engineering in some of the toughest environments.

### Electronic Monitoring Package – Standard on all Electrak HD Actuators

Safety comes first. Each HD electric linear actuator is equipped with the Electronic Monitoring Package, which will constantly monitor critical parameters and take appropriate action as needed. Each unit will reset automatically when conditions return to normal, allowing for operation to continue.

### A Wide Range of Optional Control Features Within the Same Compact Envelope

Optional control functions can eliminate the need for external controls, saving design and installation time, as well as space and installed cost. A generous selection of control configurations can tailor HD to fit a wide breadth of heavy duty applications. The available control configurations are described on the next page and more details, including wiring diagrams for each option, begin on page 24.

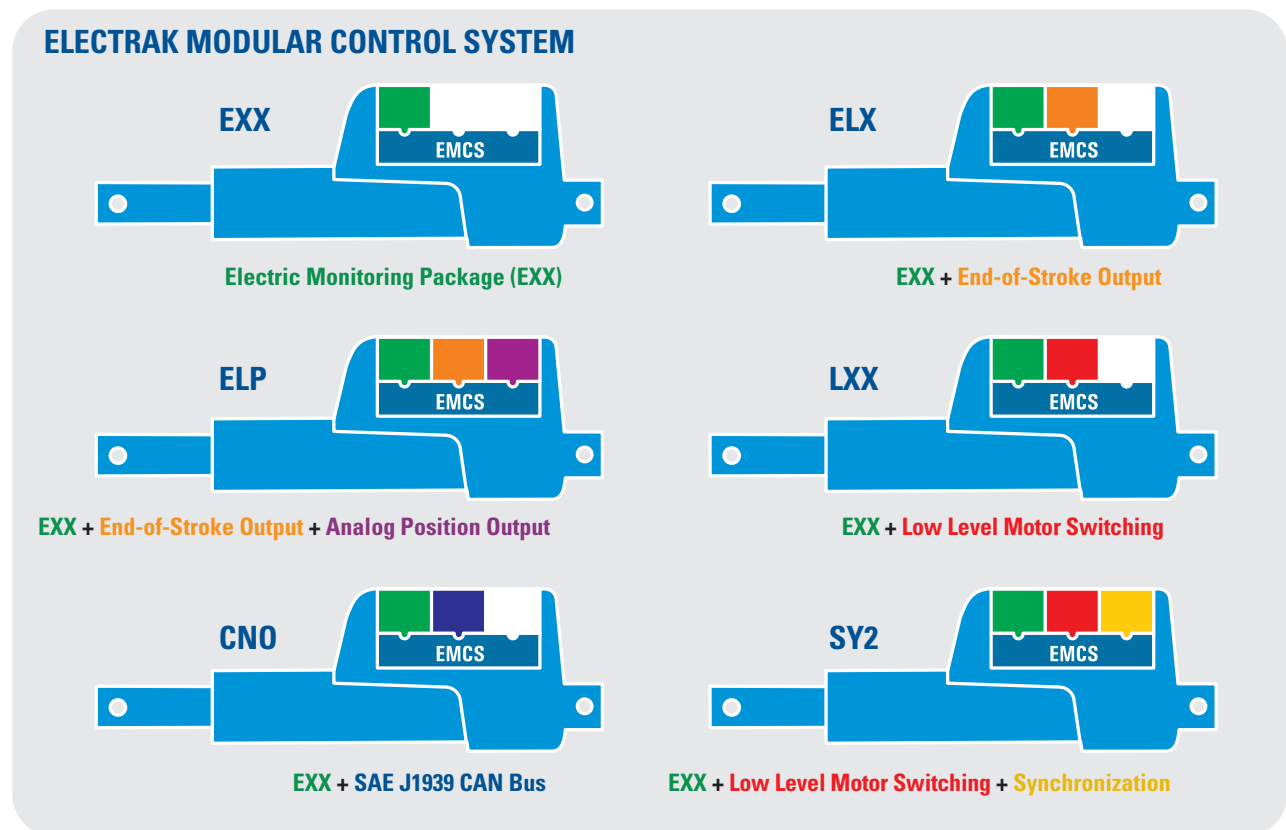

Only six of the 13 possible control option combinations shown. For the full list, see page 7.

## Electronic Monitoring Package Standard Features

### Current Monitoring

A critical safety feature that shuts down the actuator on overload and eliminates the need for the traditional mechanical clutch.

### Voltage and Temperature Monitoring

Continuous monitoring protects the actuator by preventing motion if outside normal ranges.

### Temperature Compensation

Boosts productivity by enabling normal operation at lower temperatures without nuisance tripping.

### Load Trip Point Calibration

Each Electrak HD actuator is individually calibrated at assembly to ensure a repeatable overload trip point.

### Internal End-of-Stroke Limit Switches

Built into each HD actuator, they ensure smooth, repeatable operation, and protect both connected equipment and the actuator.

### End-of-Stroke Dynamic Braking

Enables quick, end-of-stroke stops for more repeatable movements when loads would traditionally cause coasting.

## Optional Control Features

### CANopen CAN Bus

Allows plug and play connectivity on your already established CANopen network.

### SAE J1939 CAN Bus

Allows plug and play connectivity on your already established SAE J1939 network.

### Synchronization

Enables position-based motion integration of up to eight actuators.

### Low-Level Switching

Improves safety and saves energy with an auto-sleep feature, and simplifies design by using low current (< 22 mA) signals. Its soft start improves the smoothness of the move profile.

### Programmable Limit Switches

Makes it possible to set mid-stroke extend and retract software travel limits.

### Mid-Stroke Dynamic Braking

Standard with the low-level switching or CAN bus options, it reduces coast, improving repeatability.

### Limit Switch Output

Confirms successful operation by indicating the actuator is fully extended or retracted.

### Analog Position Output

A high-quality potentiometer with essentially infinite resolution and low noise provides a voltage signal for position and direction feedback.

### Digital Position Output

An encoder provides a single-channel pulse train for position and speed feedback, which can be used to allow synchronization via customer control.

### Signal Follower

Allows the actuator extension tube position to be controlled by an external signal from a potentiometer or other voltage control source.

## Control Option Combinations

Code	Control Combination Possibilities	Code	Control Combination Possibilities
EXX	Electric Monitoring Package only <sup>(1)</sup>	LXX	EXX + Low-Level Signal Motor Switching <sup>(2)</sup>
ELX	EXX + End-of-Stroke Indication Output <sup>(1)</sup>	LLX	EXX + LXX + End-of-Stroke Indication Output <sup>(2)</sup>
EXP	EXX + Analog Position Output <sup>(1)</sup>	LXP	EXX + LXX + Analog Position Output <sup>(2)</sup>
EXD	EXX + Digital Position Output <sup>(1)</sup>	LPS	EXX + LXX + Programmable Limit Switches + Signal Follower <sup>(1)</sup>
ELP	ELX + Analog Position Output <sup>(1)</sup>	CNO	SAE J1939 CAN Bus Control + Open-Loop Speed Control <sup>(2)</sup>
ELD	ELX + Digital Position Output <sup>(1)</sup>	COO	CANopen CAN Bus Control + Open-Loop Speed Control <sup>(2)</sup>
		SY2	LXX + Synchronization <sup>(2)</sup>

(1) Available for 12 and 24 Vdc models only

(2) Available for 12, 24 and 48 Vdc models



## Bus Communication – The Future of Actuator Control

Controlling an actuator over a network bus opens the door to breakthrough opportunities in machine design. More control, monitoring and feedback options can eliminate the need for separate controls. These options will also simplify design, diagnostic feedback and installation while reducing installed costs.

The built-in CAN bus option makes it possible to communicate with Electrak® HD electric linear actuators over a simple, two-wire network.

### CAN Bus in Practice

Electrak HD uses CANopen® and SAE J1939 CAN bus, well-known, mature bus standards widely used in the material handling, construction and agriculture industries. Up to eight Electrak HD actuators can be connected to the same controller and to other CAN bus controls in the network.

Complex, real-time interactions between multiple actuators and related systems are now much simpler to monitor and control.

### Application Examples

- Check position of doors and hatches and take action depending on the situation
- Monitor the temperature, overload condition or voltage variations, then take action across the network as needed. Examples: start ventilation, reduce speed or stop an operation.
- Confirm when position or other criteria are met
- Synchronize the motion of several actuators

### Benefits of CAN Bus Controls

- Better controllability – more complex, precisely controlled motion
- Improved safety – feedback in real time with all operations verified
- Shorter design cycles and installation time – CAN bus means minimal wiring, no extra control boxes and quick connection to existing networks
- Greater flexibility – use the same actuator with minor program edits for multiple applications instead of designing for unique actuators and controls for every type of application
- Reduced costs – all of the above will lead to reduced design, component, installation, operation and maintenance costs

# Control Architecture With and Without CAN Bus

## System Without CAN Bus

- A power (1) is distributed to each device
- A main control (2) system communicates separately with an individual control (3) box connected to an actuator. Each instance may require individual design, configuration, wiring and installation.
- Other equipment (4) that needs to be controlled or integrated with the actuators requires separate controls with more design and configuration required

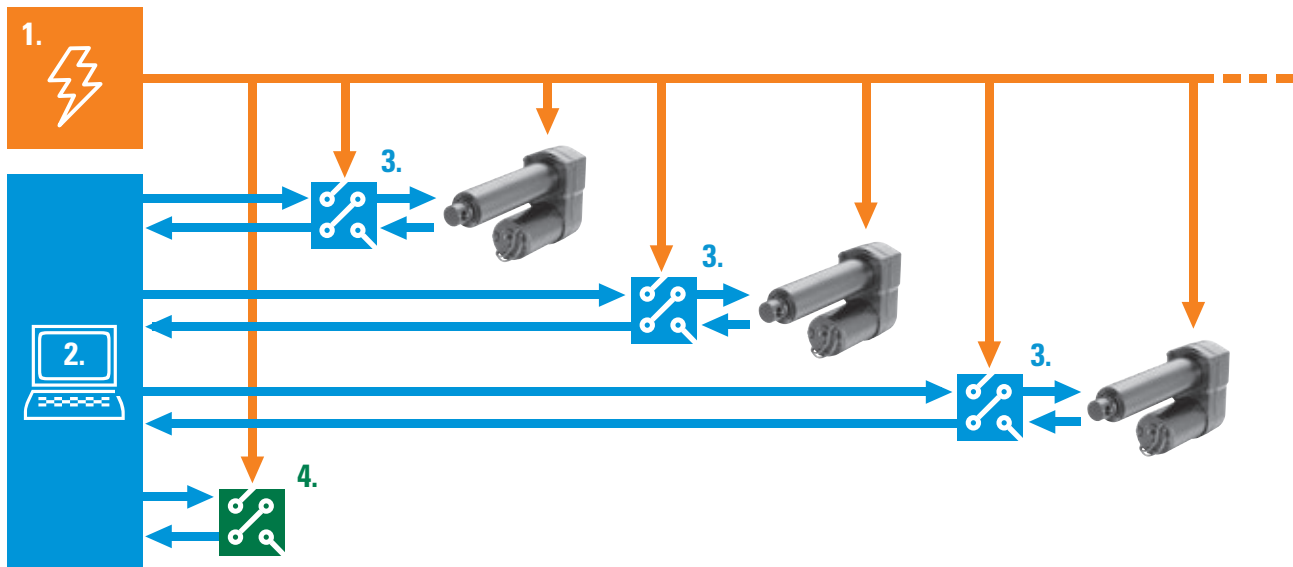

## System With CAN Bus

- A control system and actuators with CAN bus can communicate directly with each other. Adding additional, separately configured actuators is fast and easy. Only the power and a two-wire bus cable are needed to extend the network
- Any other equipment with CAN bus can be connected to the bus and communicate directly
- The result is a less complex system to design, better performance and controllability, and reduced installation time and overall cost

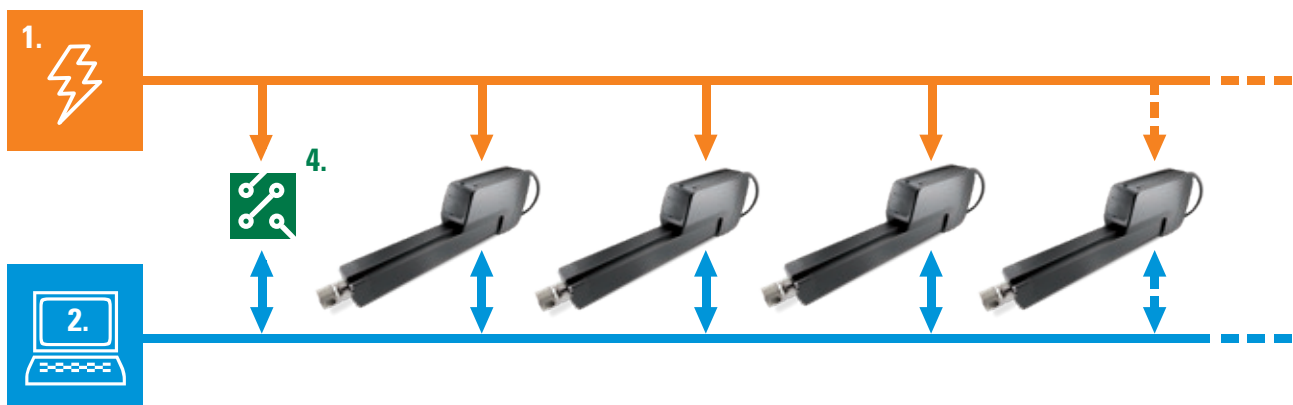



## Add Even More Control and Power with the Synchronization Option

Electrak® HD's control features undergo thorough testing at Thomson to ensure your machines are prepared for countless application challenges – both expected and unexpected. With the synchronization option, machine designers are able to easily conquer not only heavier loads but the sometimes unforeseen obstacle of actuating uneven loads as well.

Not all applications present machine designers with ideal conditions in which to work. For example, a load requiring actuation may be much heavier on one end, which could lead to potential damage to the machine or its components if handled improperly.

To address situations such as this, the synchronization feature allows up to eight Electrak HD units to share position data with each other and, by doing so, be able to work in unison and share the load. This capability, which can be utilized with the simple flip of a switch, opens up new application opportunities where a single HD actuator cannot handle the load.

At the same time, the use of multiple, heavy duty HD actuators allows users to electrify additional movement with their loads compared to hydraulic solutions.

### Benefits of Synchronization

- No more “bouncing.” When multiple actuators with synchronization are installed, designers can take advantage of a more stable and potentially quicker lift, no additional guides, and improved handling of uneven loads.
- Installation is simple and lowers the complexity of wiring up the system since the actuators have integrated controls for the synchronization feature (as opposed to an external sync control).

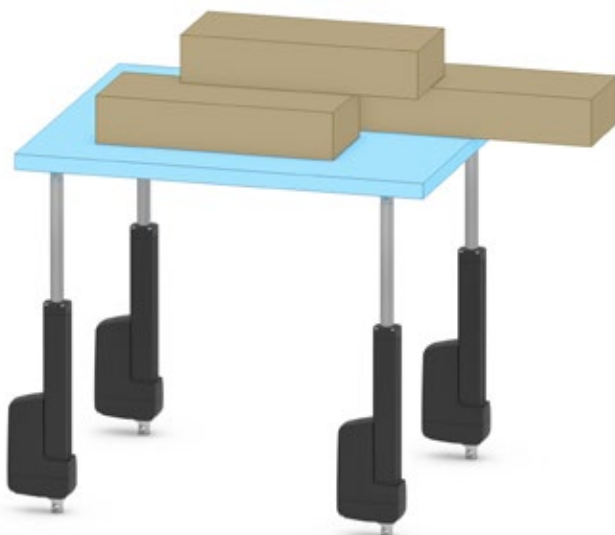

Each Electrak HD can push or pull up to its maximum dynamic load capacity in an effort to automate an uneven load in a synchronized fashion.

### WHY SYNCHRONIZE?

- Handle uneven or awkward loads
- Lift heavier loads
- Integrate movement of multiple end points
- Eliminate mechanical linkage

# Synchronization Applications

## Door/Hatch Lifts

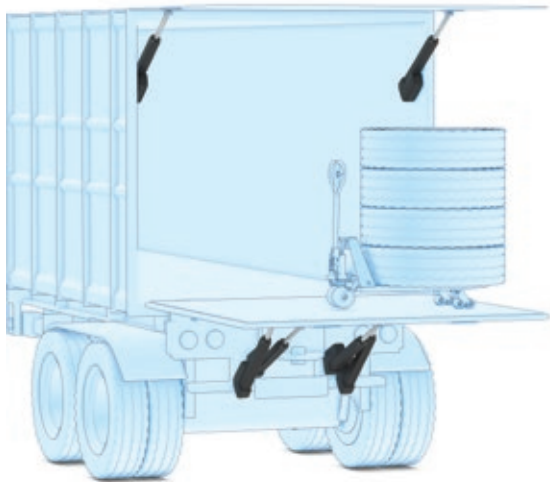

Utilizing synchronization for mobile lifting platforms on vehicles provides a robust, reliable solution without the complexity and maintenance requirements of a traditional hydraulic solution.

## Assembly Stations

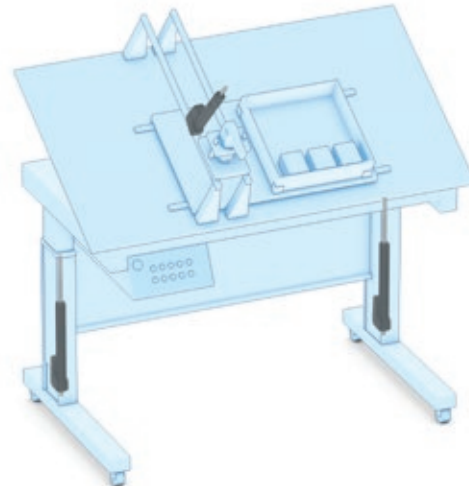

Placing the Electrak HD with synchronization into your ergonomic applications ensures a stable, effective lift for off-center or awkward loads.

## Solar Panels

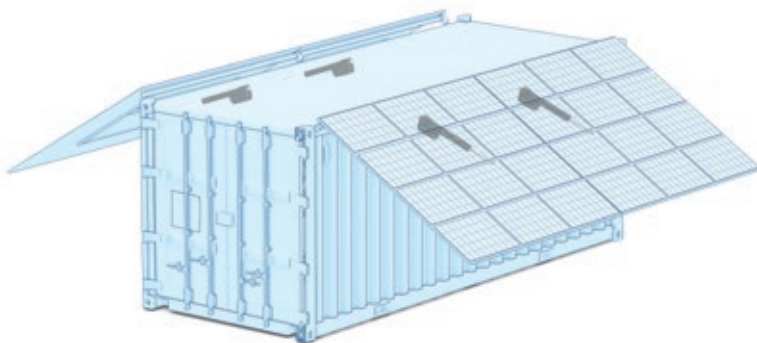

The Electrak HD is an industrial solution that can handle heavy loads – such as large solar panels – in rugged installations. These heavier loads, which would typically require structural support and larger actuation solutions, can be easily lifted with multiple HD actuators in sync.

## Automated Guided Vehicles

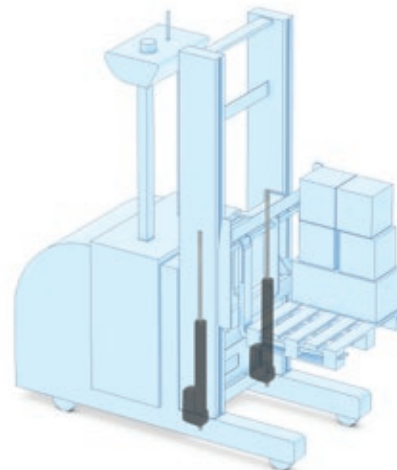

Applications using automation can benefit from internal condition monitoring with every HD actuator. This keeps the actuators running within rated specification and shuts them down if temperatures rise, loads are exceeded or input voltage is insufficient.



## Electrak<sup>®</sup> HD – Smarter, Stronger, Longer

In addition to advanced control features, the Electrak HD offers 50% higher load capacity and 60% longer stroke lengths than previous designs, and is faster than the competition at comparable loads. This extended envelope of operation also opens a larger range of hydraulic-to-electric application conversions.



Electrak HD offers smart design solutions, like built-in cable management, an integrated connector and a manual override feature on every actuator.



Building on the capabilities of the Electrak 10, the workhorse of electric actuators for decades, the Electrak HD offers onboard controls, higher load



capacity (up to 16 kN [3600 lbs.]), longer strokes (up to 1 m [39 in.] / 500 mm [20 in.] for 16 kN) and higher speeds.

## Ready to Work in Extreme Environments

The Electrak HD is well suited for heavy duty, industrial applications, including conversion of hydraulic to electric actuation. It shows its mettle when used under the harshest conditions. Each HD actuator is designed to meet and exceed the toughest OEM mechanical and electrical components tests, including IP69K.





## Accelerated Trend Toward Electric Conversions

Once dominated by manual, pneumatic and hydraulic systems, mobile on- and off-highway equipment is increasingly equipped with electric actuators to automate many tasks. Electric linear actuators are easier to integrate with modern computer-based control systems and are precisely controlled. They consume a smaller footprint and are cleaner than both pneumatic and hydraulic systems.

### **Converting to Electric Immediately Eliminates:**

- the cost and bulk of pumps, valves and hoses.
- environmentally hazardous oil and leaks.
- costly hydraulic reliability issues and contamination.
- the high-energy consumption of pneumatic and hydraulic systems.
- nuisance start-up failures in cold temperatures.

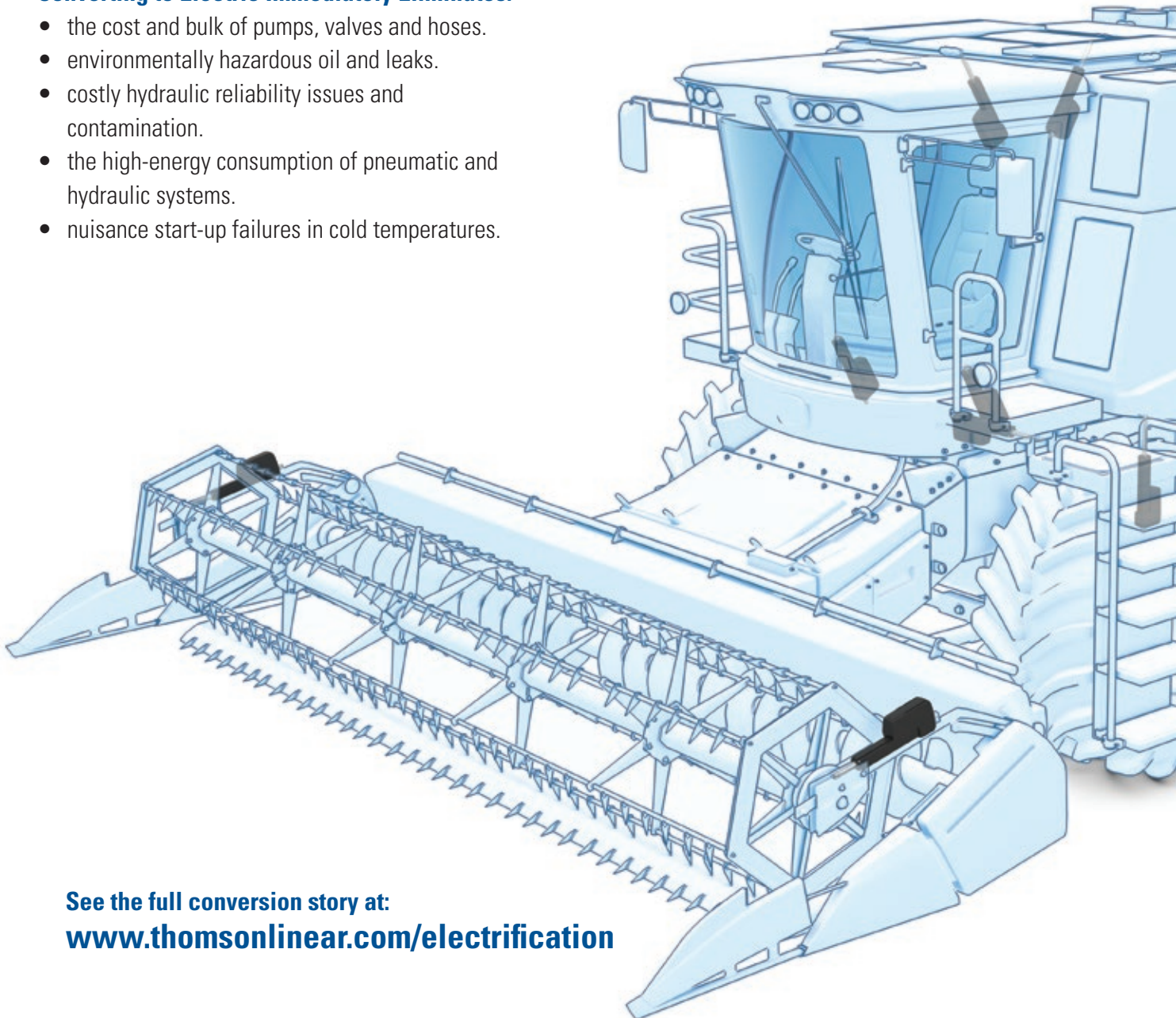

See the full conversion story at:  
[www.thomsonlinear.com/electrification](http://www.thomsonlinear.com/electrification)

## Easier Installation, Superior Control and Less Complexity

### Simpler, Smaller and Faster to Install

- Electric actuators require fewer components than hydraulic or pneumatic systems for faster and easier installation
- Component costs are less than in comparable hydraulic or pneumatic systems
- A smaller footprint simplifies and speeds design

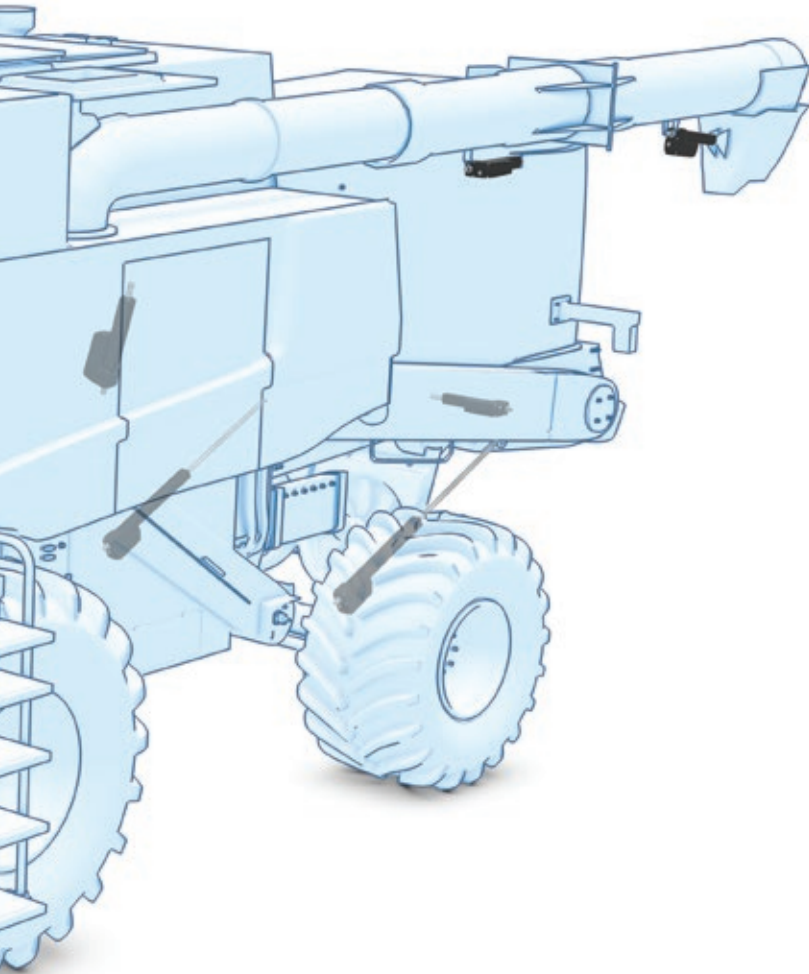

### Easier Control, Better Accuracy

- All-electric components mean easier integration, fewer control components and less complexity
- Electric actuators react quicker and more predictably, and will not drift when power is off

### Lower Energy Costs

- Electric motors are intrinsically more efficient than pneumatic or hydraulic motors
- No need to up-size the existing system to account for potential parasitic power draw
- No power required to hold load-reducing power consumption

### Less Maintenance

- No hydraulic pumps, valves or hoses means reduced downtime with fewer parts to service and replace
- Self-contained units with smart, onboard electronics require zero maintenance, adding design flexibility in component placement
- Electric actuation eliminates the cost and hassle associated with fluid maintenance

### Cleaner, Quieter, Healthier Environment

- No pumps, fluids, chemicals or solvents translates into a cleaner, safer and quieter workspace
- A compact design requires fewer materials to be used in production
- Regional manufacturing and distribution plants minimize freight and reduce the carbon footprint



## Improving Machine Design with Electric Actuators

These applications illustrate how the Electrak® HD can deliver huge benefits over pneumatic and hydraulic mechanisms, including reduced design, installation and operation costs, while improving controllability, safety and productivity.

### Single-User Maintenance and Repair

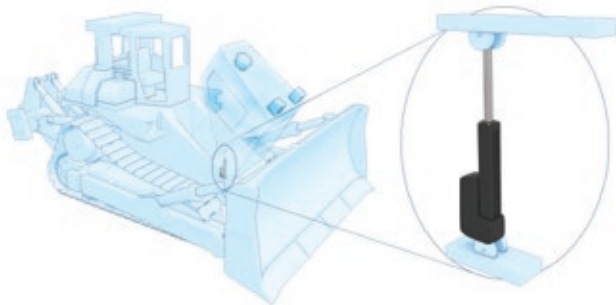

Electric linear actuators enable a single maintenance or repair technician to access the engine compartment quickly and safely.

### Quick-Attach

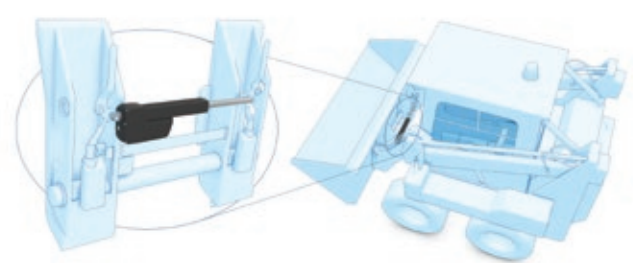

Quick-attach actuators allow the operator to change implements on the loader or skid steer without leaving the seat for improved productivity and safety.

### Utility Vehicles

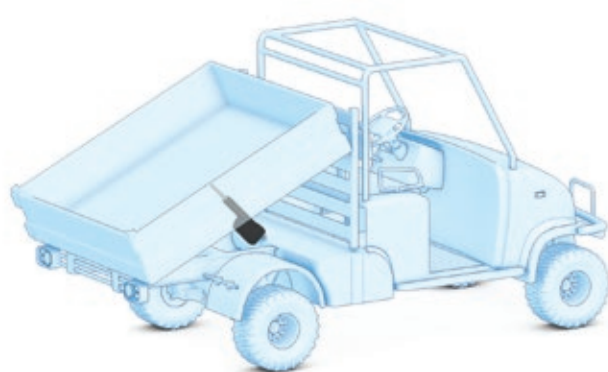

Garden, construction and service vehicles require rugged, efficiently controlled performance. The environmental protection (IP69K), high load capabilities and CAN bus communication provide that performance.

### Roadwork and Construction Site Equipment

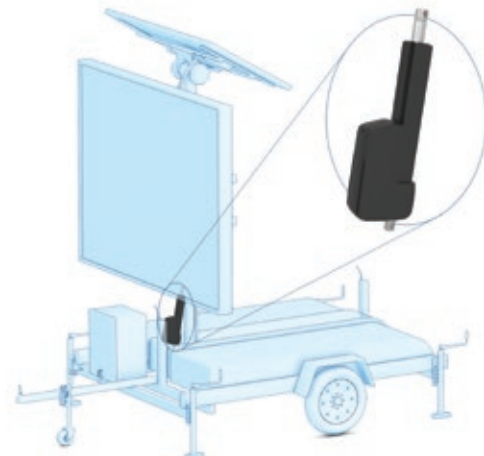

Long stroke, protection against harsh environments and high load rating (including high shock loading for wind shear) make the Electrak HD a great fit for this roadside construction sign.

## Railroad Equipment

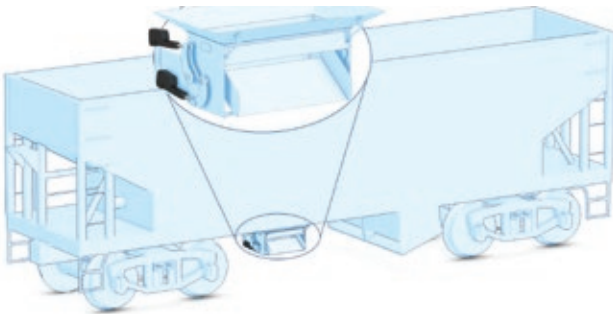

Railroad equipment experiences the toughest conditions. Whether it is to open and close a gravity bin or to control a pantograph, the Electrak HD actuator will perform effectively despite harsh weather, heavy vibrations or high-pressure washing.

## Logistic Systems

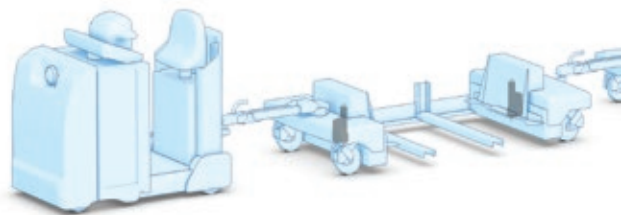

The Electrak HD, with its built-in CAN bus capabilities, makes it easy to build intelligent logistic systems such as the material handling train shown here.

## Emergency and Rescue Vehicles

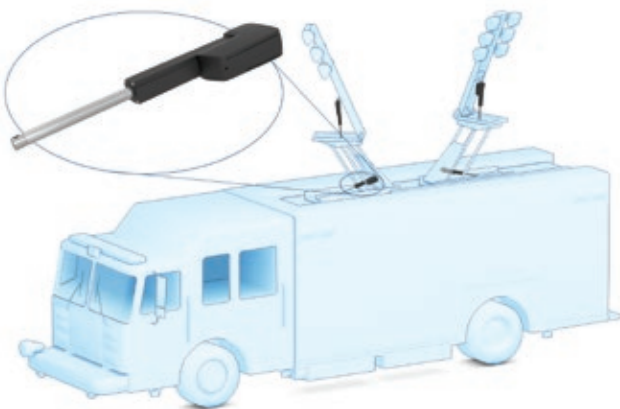

The deployment of lighting on emergency vehicles demands the most reliable operation. Electrak HD is easily controlled, has a built-in manual override and operates reliably in all weather to help emergency responders perform their jobs safely.

## Switch Gears

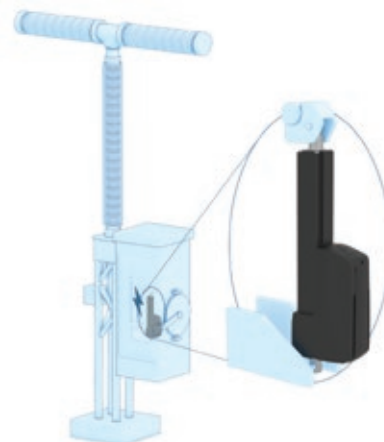

Electrical switch gears are often placed in remote locations. It is critical that power switching is executed and confirmed without fail. Electrak HD is ideal for this task in arctic to high-temperature conditions.



# Electrak® HD Technical Features



## Optional Features

Parameter	Electrak HD
Mechanical options	Variety of front and rear adapters
	Alternative adapter orientation
Control options (see page 24)	End-of-stroke output
	Analog position feedback
	Digital position feedback
	Programmable limit switches
	Signal follower
	Low-level signal motor switching
	CANopen® CAN bus
	SAE J1939 CAN bus
Synchronization	

## General Specifications

Parameter	Electrak HD
Screw type	ball
Nut type	load lock ball nut
Manual override	yes
Anti-rotation	yes
Dynamic braking	yes <sup>(1)</sup>
Static load holding brake	yes
End-of-stroke protection	internal end-of-stroke limit switches
Overload protection	yes
Temperature monitoring	yes
Temperature compensation	yes
Voltage monitoring	yes
Electrical connections <sup>(2)</sup>	cable(s) with flying leads
Compliance	CE

(1) Dynamic braking is included at the ends of stroke for all Electrak HD actuators. Dynamic braking is offered throughout the entire stroke length only on low-level switching and SAE J1939 options.

(2) There are one or two cables depending on the control option used. The cable(s) enters the actuator via a connector. The replacement of an actuator can be completed by unplugging the old actuator and plugging in the new one.

## Accessories

Parameter	Electrak HD
Mechanical	Rod end front adapter
Electrical	External slot-mounted limit switches

## Cable Definitions

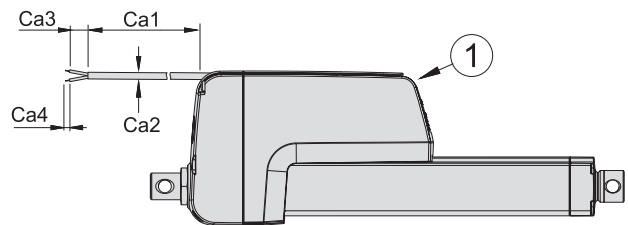

The drawing shows the cables exiting the cable slots at the end of the actuator housing, which is the shipping position. The user can adjust the exit point to be anywhere between the connector (1) in the front of the housing and the end of the cable slots.

# Electrak HD Technical Specifications

Mechanical Specifications		
Parameter		Electrak HD
Max. static load <sup>(1)</sup>	[kN (lbs)]	18 (4050)
Max. dynamic load (Fx)	[kN (lbs)]	
HDxx-B017		1.7 (382)
HDxx-B026		2.6 (585)
HDxx-B045		4.5 (1012)
HDxx-B068		6.8 (1529)
HDxx-B100		10 (2248)
HDxx-B160		16 (3584)
Speed @ no load/max. load <sup>(2)</sup>	[mm/s (in/s)]	
HDxx-B017		71/58 (2.8/2.28)
HDxx-B026		40/32 (1.6/1.3)
HDxx-B045		24/19 (0.94/0.75)
HDxx-B068		18/14 (0.71/0.55)
HDxx-B100		11/9 (0.43/0.35)
HDxx-B160		7/5 (0.27/0.21)
Min. ordering stroke (S) length	[mm]	100
Max. ordering stroke (S) length <sup>(3)</sup>	[mm]	1000
Ordering stroke length increments	[mm]	50
Operating temperature limits	[°C (F)]	-40 – 85 (-40 – 185)
Full load duty cycle @ 25 °C (77 °F)	[%]	25 <sup>(4)</sup>
End play, maximum	[mm (in)]	1.2 (0.047)
Restraining torque	[Nm (lbs)]	0
Protection class - static		IP67 / IP69K
Protection class - dynamic		IP66
Salt spray resistance	[h]	500

<sup>1</sup> Max. static load at fully retracted stroke.

<sup>2</sup> For units with the synchronization option, the speed will vary slightly when synchronizing, but will typically remain close to the speed they are rated for at full load. See page 29 for more information on the synchronization option.

<sup>3</sup> 500 mm max. for 16 kN.

<sup>4</sup> For HDxx-B100 and HDxx-160 load, the duty cycle is 15%.

<sup>5</sup> Do not use PWM voltage for speed control to avoid damaging the onboard electronics.

<sup>6</sup> See previous page for cable definitions.

Electrical Specifications		
Parameter		Electrak HD
Available input voltages <sup>(5)</sup>	[Vdc]	12, 24, 48
Input voltage tolerance	[Vdc]	
HD12 (12 Vdc input voltage)		9 - 16
HD24 (24 Vdc input voltage)		18 - 32
HD48 (48 Vdc input voltage)		36 - 64
Current draw @ no load/max. load	[A]	
HD12-B017		3/18
HD24-B017		1.5/9
HD48-B017		0.75/4.5
HD12-B026		3/18
HD24-B026		1.5/9
HD48-B026		0.75/4.5
HD12-B045		3/18
HD24-B045		1.5/9
HD48-B045		0.75/4.5
HD12-B068		3/20
HD24-B068		1.5/10
HD48-B068		0.75/5
HD12-B100		3/18
HD24-B100		1.5/9
HD48-B100		0.75/4.5
HD12-B160		3/20
HD24-B160		1.5/10
HD48-B160		0.75/5
Motor leads cross section	[mm <sup>2</sup> (AWG)]	2 (14)
Signal leads cross section	[mm <sup>2</sup> (AWG)]	0.5 (20)
Standard cable lengths (Ca1) <sup>(6)</sup>	[m (in)]	0.3, 1.5, 5 (11.8, 59, 197)
Cable diameter (Ca2) <sup>(6)</sup>	[mm (in)]	7.5 (.295)
Flying lead length (Ca3) <sup>(6)</sup>	[mm (in)]	76 (3)
Stripped lead length (Ca4) <sup>(6)</sup>	[mm (in)]	6 (0.25)

## Actuator Weight [kg]

Maximum Dynamic Load (Fx) [kN (lbs)]	Ordering Stroke (S) [mm]																		
	100	150	200	250	300	350	400	450	500	550	600	650	700	750	800	850	900	950	1000
1.7 (382)	6.5	6.7	7.0	7.2	7.5	7.7	8.0	8.2	8.5	8.7	9.0	9.2	9.5	9.7	10.0	10.2	10.5	10.7	11.0
2.6 (585)	6.5	6.7	7.0	7.2	7.5	7.7	8.0	8.2	8.5	8.7	9.0	9.2	9.5	9.7	10.0	10.2	11.6	11.9	12.2
4.5 (1012)	6.5	6.7	7.0	7.2	7.5	7.7	8.0	8.2	8.5	8.7	9.0	9.2	10.4	10.7	11.0	11.3	11.6	11.9	12.2
6.8 (1592)	6.5	6.7	7.0	7.2	7.5	7.7	8.0	8.2	8.5	9.5	9.8	10.1	10.4	10.7	11.0	11.3	11.6	11.9	12.2
10 (2248)	6.7	7.0	7.2	7.5	7.7	8.0	8.2	9.1	9.4	9.7	10.0	10.3	10.6	10.9	11.2	11.5	11.8	12.1	12.4
16 (3584)	8.1	8.3	8.5	8.7	8.9	9.1	9.3	9.5	9.7										

Conversion Factors: Millimeter to inch: 1 mm = 0.03937 in, kilogram to pound: 1 kg = 2.204623 lbs



# How to Order the Electrak® HD

This ordering key provides a quick overview of the product versions available. It is important to consider many application details when selecting a product, including the loads, speeds and control options required, as well as the product environment and necessary accessories. More information can be found at [www.thomsonlinear.com/hd](http://www.thomsonlinear.com/hd).

## Ordering Key

1	2	3	4	5	6	7	8	9
<b>HD12</b>	<b>B026-</b>	<b>0300</b>	<b>LXX</b>	<b>2</b>	<b>M</b>	<b>M</b>	<b>S</b>	<b>D</b>
<p><b>1. Model and input voltage</b>            HD12 = Electrak HD, 12 Vdc            HD24 = Electrak HD, 24 Vdc            HD48 = Electrak HD, 48 Vdc</p> <p><b>2. Screw type, dynamic load capacity</b>            B017 = ball screw, 1.7 kN (382 lbf)            B026 = ball screw, 2.6 kN (585 lbf)            B045 = ball screw, 4.5 kN (1012 lbf)            B068 = ball screw, 6.8 kN (1529 lbf)            B100 = ball screw, 10 kN (2248 lbf)            B160 = ball screw, 16 kN (3584 lbf)</p> <p><b>3. Ordering stroke length <sup>(1) (2)</sup></b>            0050 = 50 mm <sup>(3)</sup>            0100 = 100 mm            0150 = 150 mm            0200 = 200 mm            0250 = 250 mm            0300 = 300 mm            0350 = 350 mm            0400 = 400 mm            0450 = 450 mm            0500 = 500 mm            0550 = 550 mm            0600 = 600 mm            0650 = 650 mm            0700 = 700 mm            0750 = 750 mm            0800 = 800 mm            0850 = 850 mm            0900 = 900 mm            0950 = 950 mm            1000 = 1000 mm</p> <p><small>(1) Other stroke lengths available upon request. Please contact customer support.            (2) 500 mm is the max. stroke length for 16 kN units.            (3) 50 mm stroke units will have same retracted length and envelope size as a 100 mm unit.            (4) Max. ordering stroke for the rear mounting flange type A is 300 mm.            (5) Max. dynamic load capacity for the rear mounting flange type A is 10 kN.</small></p>	<p><b>4. Electrak Modular Control System options</b></p> <p>Options available for HD12 and HD24 only            EXX = Electronic Monitoring Package only            ELX = EXX + end-of-stroke indication output            EXP = EXX + analog (potentiometer) position output            EXD = EXX + digital position output            ELP = ELX + analog (potentiometer) position output            ELD = ELX + digital position output            LPS = EXX + LXX + programmable limit switches + signal-follower</p> <p>Options available for HD12, HD24 and HD48            LXX = EXX + low-level signal motor switching            LLX = EXX + LXX + end-of-stroke indication output            LXP = EXX + LXX + analog (potentiometer) position output            CNO = SAE J1939 CAN bus + open-loop speed control            COO = CANopen CAN bus + open-loop speed control            SY2 = LXX + synchronization option</p> <p><b>5. Cable length</b>            1 = 0.3 m long cables            2 = 1.5 m long cables            3 = 5.0 m long cables</p> <p><b>6. Rear adapter/mounting flange options</b>            A = rear mounting flange <sup>(4) (5)</sup>            M = cross hole for 12 mm pin            E = cross hole for ½ inch pin            N = forked cross hole for 12 mm pin            F = forked cross hole for ½ inch pin</p> <p><b>7. Front adapter options</b>            A = metric M16 male thread            M = cross hole for 12 mm pin            E = cross hole for ½ inch pin            N = forked cross hole for 12 mm pin            F = forked cross hole for ½ inch pin            P = metric M12 female thread            G = inch 1/2-20 UNF-2B female thread</p> <p><b>8. Adapter orientation</b>            S = standard            M = 90 ° turned</p> <p><b>9. Connection options</b>            D = flying leads</p>							

# Performance Diagrams

Load vs. Speed <sup>(1)</sup>

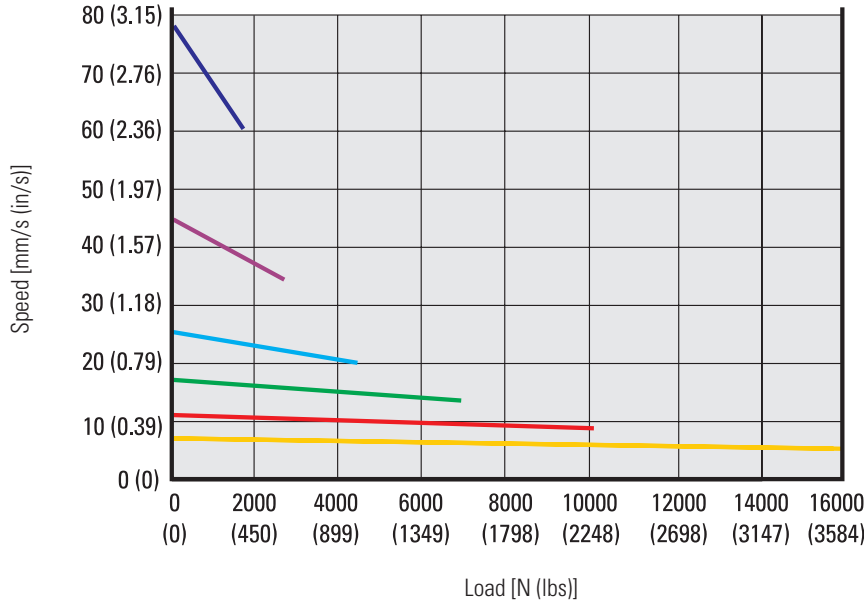

<sup>1</sup> Curves valid for all units except those with the synchronization option, where the speed may vary, but will typically remain close to the speed they are rated for at full load, even if they are running at a lower load.

Load vs. Life

Load (kN)	Stroke (mm)	Life (cycles)
1.7	300	60,000
2.6		40,000
4.5		20,000
6.8		10,000
10		7,500
16		4,000

The life of an actuator is dependent upon the application in which it is used. The table above provides estimates based on a 300 mm stroke that is fully loaded throughout the entire cycle. If you have any questions regarding the life of the Electrak HD in your specific application, please contact Thomson Customer Support.

Load vs. Current

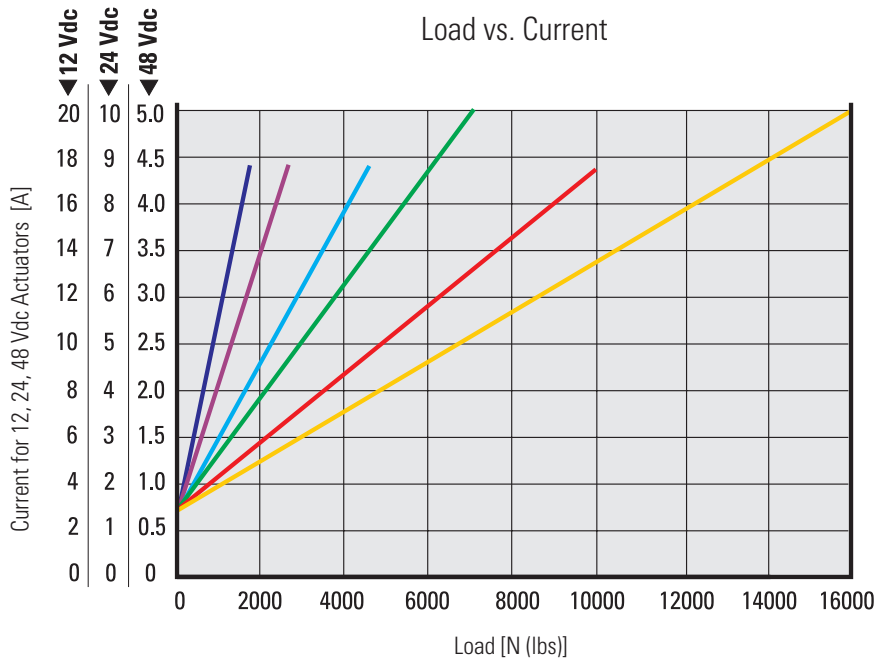

Screw Type and Dynamic Load Capacity

- ball screw, 1.7 kN (382 lbs) █
- ball screw, 2.6 kN (585 lbs) █
- ball screw, 4.5 kN (1012 lbs) █
- ball screw, 6.8 kN (1529 lbs) █
- ball screw, 10 kN (2248 lbs) █
- ball screw, 16 kN (3584 lbs) █

**Note!** Curves were generated at an ambient temperature of 21°C (70°F). Different ambient temperature and individual actuator characteristics can produce slightly different values.

# Dimensions

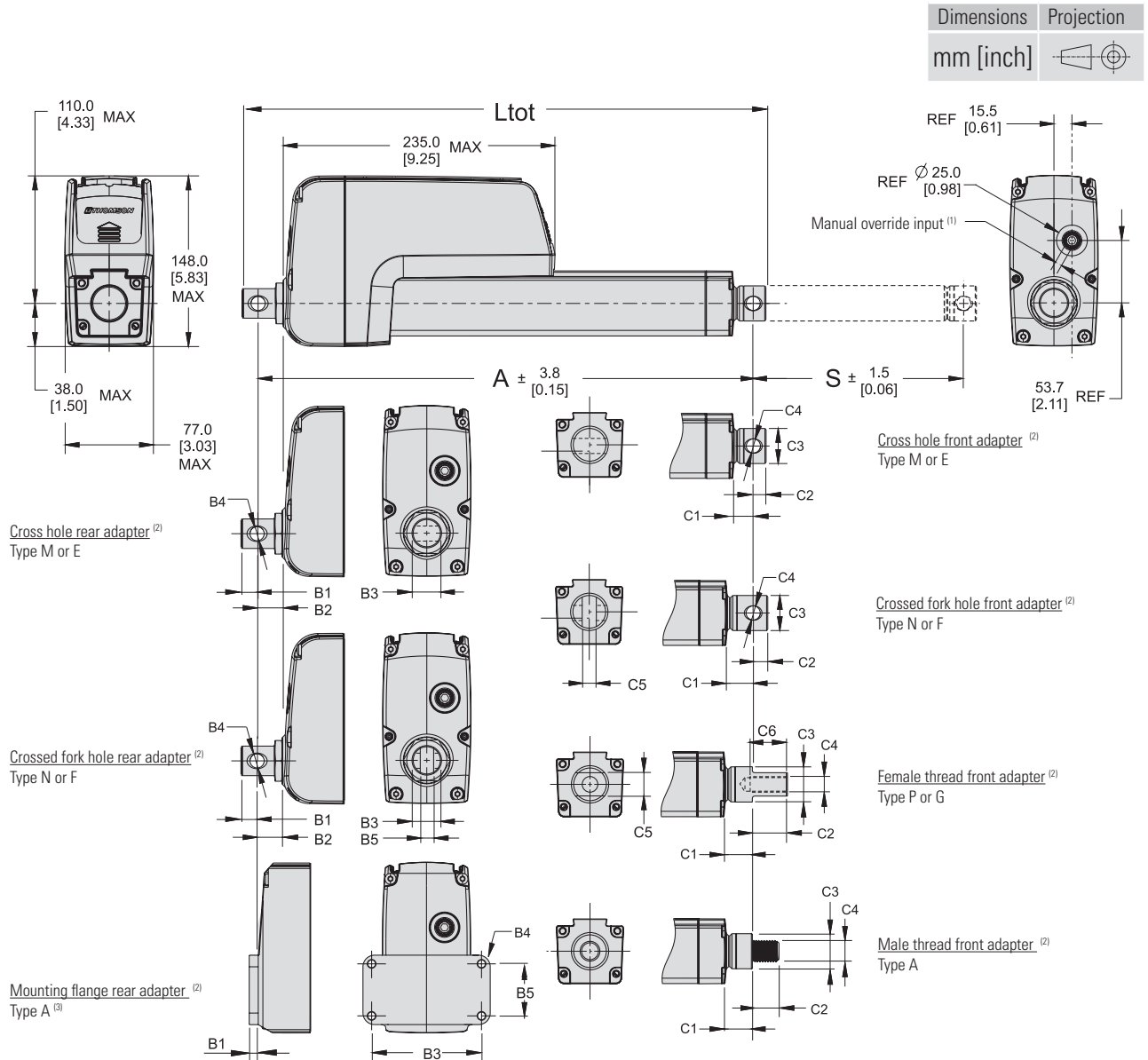

Rear and Front Adapter Dimensions [mm (in)]

	Rear Adapter Types						Front Adapter Types						
	M	E	N	F	A <sup>(3)</sup>		M	E	N	F	P	G	A
B1	13.4 (0.53)				7.8 (0.31)	C1	see table on next page						16.5 (0.65)
B2	21.6 (0.85)				-	C2	10.9 (0.43)	12.9 (0.51)		30.0 (1.18)		20.0 (0.79)	
B3	25.4 (1.0)				95.0 (3.70)	C3	see table on next page						
B4	12.2 (0.48)	12.8 (0.51)	12.2 (0.48)	12.8 (0.51)	6.6 (0.26)	C4	12.2 (0.48)	12.8 (0.51)	12.2 (0.48)	12.8 (0.51)	M12 × 1.75	1/2-20 UNF-2B	M16 × 2
B5	-	-	8.2 (0.32)		45.0 (1.77)	C5	-	-	8.2 (0.32)		19.0 (0.75)		-
						C6	-	-	-	-	35.0 (1.38)		-

(1) The input hole is covered with a plastic threaded plug. When removed, a 6 mm socket can be inserted and used as a crank.

(2) All adapters shown in the standard orientation.

(3) Rear mounting flange type A cannot be ordered with a higher maximum static load capacity than 10 kN or/and a maximum stroke of 300 mm.

# Dimensions

Maximum Dynamic Load and Stroke Relationships							
Maximum Dynamic Load (Fx) - kN (lbs.)	Total Length (Ltot), Retracted Length (A) and Adapter Dimensions [mm]	Ordering Stroke (S) [mm]					
		100 – 500	550 – 600	650 – 700	750 – 900	950 – 1000	
1.7 (382)	Ltot	A + B1 + C2					
	A	S + 150.9 + B2 + C1					
	C1	Type M, E	17.5				
		Type N, F	26.5				
		Type P, G	23.9				
C3	30.2						
2.6 (585)	Ltot	A + B1 + C2			A + B1 + C2		
	A	S + 150.9 + B2 + C1			S + 156.8 + B2 + C1		
	C1	Type M, E	17.5			24.0	
		Type N, F	26.5			27.0	
		Type P, G	23.9			24.9	
C3	30.2			35.0			
4.5 (2012)	Ltot	A + B1 + C2			A + B1 + C2		
	A	S + 150.9 + B2 + C1			S + 156.8 + B2 + C1		
	C1	Type M, E	17.5			24.0	
		Type N, F	26.5			27.0	
		Type P, G	23.9			24.9	
C3	30.2			35.0			
6.8 (1529)	Ltot	A + B1 + C2			A + B1 + C2		
	A	S + 150.9 + B2 + C1			S + 156.8 + B2 + C1		
	C1	Type M, E	17.5			24.0	
		Type N, F	26.5			27.0	
		Type P, G	23.9			24.9	
C3	30.2			35.0			
10 (2248)	Ltot	A + B1 + C2		A + B1 + C2			
	A	S + 180.9 + B2 + C1		S + 182 + B2 + C1			
	C1	Type M, E	17.5		24.0		
		Type N, F	26.5		27.0		
		Type P, G	23.9		24.9		
C3	30.2		35.0				
16 (3584)	Ltot	A + B1 + C2					
	A	S + 182 + B2 + C1					
	C1	Type M, E	24.0				
		Type N, F	27.0				
		Type P, G	24.9				
C3	35.0						

# Control Options

Electrak® HD electric linear actuators feature the Electrak Modular Control System, and each unit is shipped with the Electronic Monitoring Package. A generous offering of optional control and feedback features can be configured to fit most applications – all within the same design envelope. Details for each control option and its wiring are described on the following pages. Please contact customer support for more information at [www.thomsonlinear.com/cs](http://www.thomsonlinear.com/cs).

## Control Option Type EXX

Actuator supply voltage	[Vdc]	
HD12		9 - 16
HD24		18 - 32
HD48		-
Actuator current draw	[A]	see page 19

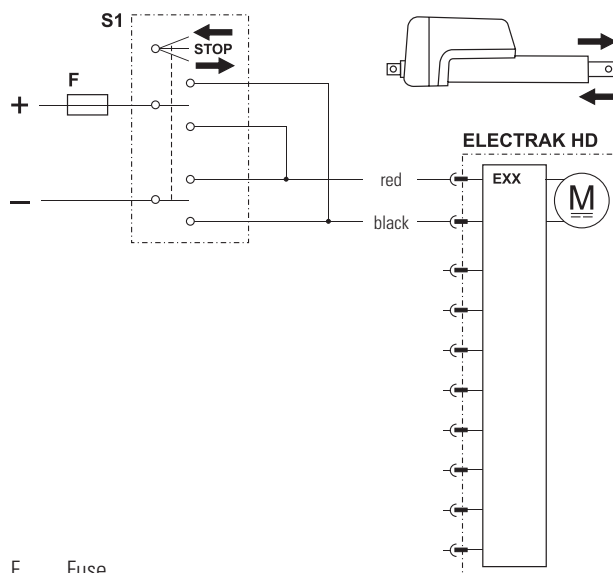

- F Fuse
- S1 Double pole double throw switch

Control option EXX contains all of the basic Electronic Monitoring Package features described on page 7, guaranteeing safe operation of the actuator and equipment. With control option EXX, the polarity of the motor voltage is switched by a customer-supplied switch (switch, relay, etc.) to make the actuator extend or retract. The switch, power supply, wiring and all other components must be able to handle the motor current for the actuator model and load being used, as well as the inrush current (up to three times the max. continuous current for the max. load being used for up to 150 milliseconds).

## Control Option Type ELX

Actuator supply voltage	[Vdc]	
HD12		9 - 16
HD24		18 - 32
HD48		-
Actuator current draw	[A]	see page 19
Output contact type		potential free
Limit switch max. switch voltage	[Vdc/ac]	30/120
Limit switch max. switch current	[mA]	100

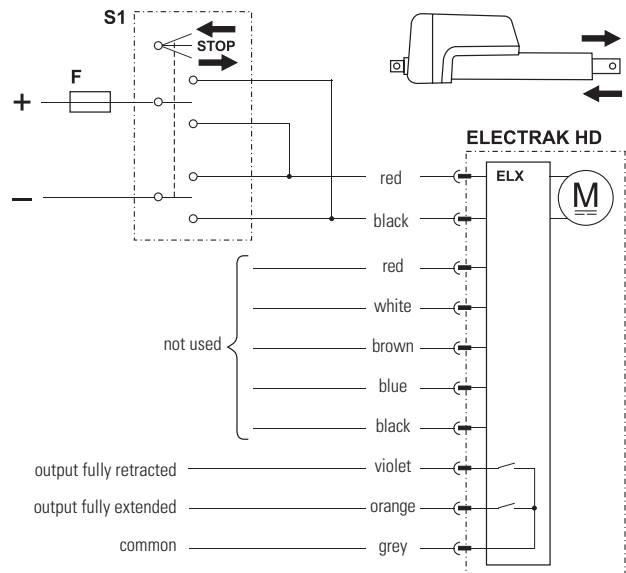

- F Fuse
- S1 Double pole double throw switch

Control option ELX works as option EXX but also has two outputs that indicate when the extension tube is in its fully extended or retracted position.

# Control Options

## Control Option Type EXP

Actuator supply voltage	[Vdc]	
HD12		9 - 16
HD24		18 - 32
HD48		-
Actuator current draw	[A]	see page 19
Potentiometer type		wirewound
Potentiometer max. input voltage	[Vdc]	32
Potentiometer max. power	[W]	1
Potentiometer linearity	[%]	± 0.25
Potentiometer output resolution	[ohm/mm]	
50 - 100 mm stroke		65.6
150 - 250 mm stroke		32.8
300 - 500 mm stroke		19.7
550 - 1000 mm stroke		9.8

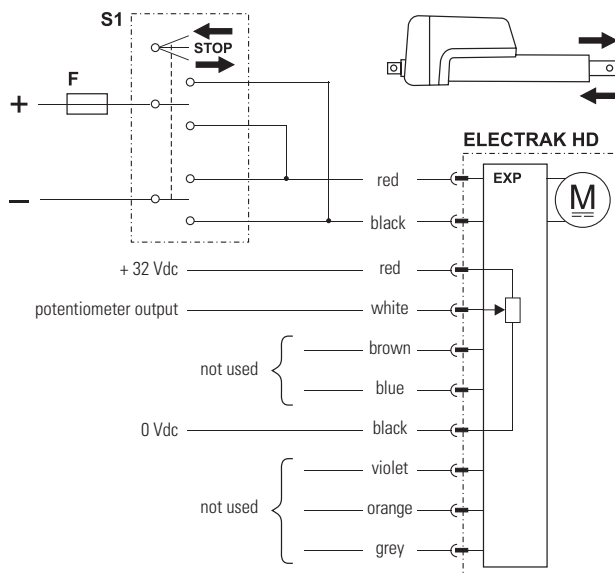

F Fuse

S1 Double pole double throw switch

Control option EXP works as option EXX but also has an analog (potentiometer) output that will provide feedback on the extension tube position.

## Control Option Type EXD

Actuator supply voltage	[Vdc]	
HD12		9 - 16
HD24		18 - 32
HD48		-
Actuator current draw	[A]	see page 19
Encoder type		hall effect
Encoder input voltage	[Vdc]	4 - 24
Encoder output voltage levels	[Vdc]	
low (logical zero), typical / max.		0.1 / 0.25
Encoder resolution	[mm/pulse]	
HDxx-B017		0.28
HDxx-B026		0.15
HDxx-B045		0.09
HDxx-B068		0.07
HDxx-B100		0.04
HDxx-B160		0.03

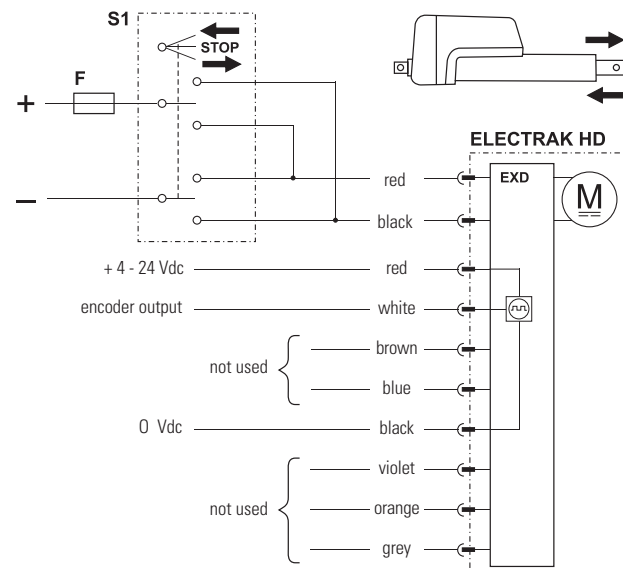

F Fuse

S1 Double pole double throw switch

Control option EXD works as option EXX but also has a single-channel encoder output that will provide feedback on the extension tube position.

# Control Options

## Control Option Type ELP

Actuator supply voltage	[Vdc]	9 - 16 HD12 HD24 HD48
Actuator current draw	[A]	see page 19
Output contact type		potential free
Limit switch max. switch voltage	[Vdc/ac]	30/120
Limit switch max. switch current	[mA]	100
Potentiometer type		wirewound
Potentiometer max. input voltage	[Vdc]	32
Potentiometer max. power	[W]	1
Potentiometer linearity	[%]	± 0.25
Potentiometer output resolution	[ohm/mm]	65.6 50 - 100 mm stroke 32.8 150 - 250 mm stroke 19.7 300 - 500 mm stroke 9.8 550 - 1000 mm stroke

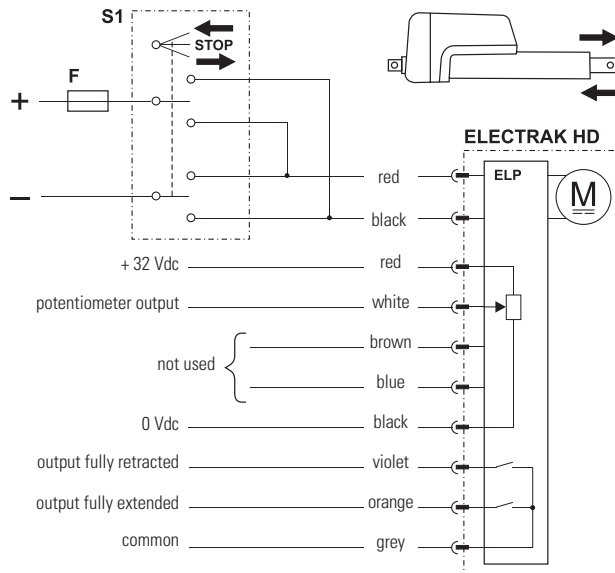

F Fuse  
S1 Double pole double throw switch

Control option ELP works as option EXP but also has two outputs that indicate when the extension tube is in its fully extended or retracted position.

## Control Option Type ELD

Actuator supply voltage	[Vdc]	9 - 16 HD12 HD24 HD48
Actuator current draw	[A]	see page 19
Output contact type		potential free
Limit switch max. switch voltage	[Vdc/ac]	30/120
Limit switch max. switch current	[mA]	100
Encoder type		hall effect
Encoder input voltage	[Vdc]	4 - 24
Encoder output voltage levels	[Vdc]	low (logical zero), typical / max. 0.1 / 0.25
Encoder resolution	[mm/pulse]	0.28 HDxx-B017 0.15 HDxx-B026 0.09 HDxx-B045 0.07 HDxx-B068 0.04 HDxx-B100 0.03 HDxx-B160

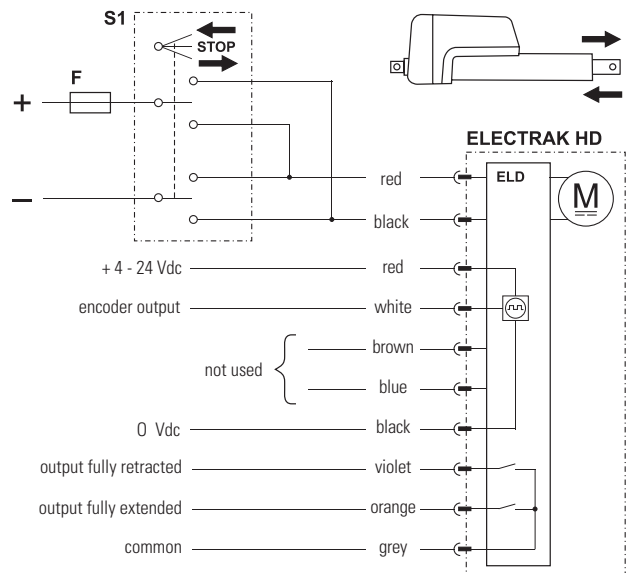

F Fuse  
S1 Double pole double throw switch

Control option ELD works as option EXD but also has two outputs that indicate when the extension tube is in its fully extended or retracted position.

## Control Options

### Control Option Type LXX

Actuator supply voltage	[Vdc]	
HD12		9 - 16
HD24		18 - 32
HD48		36 - 64
Actuator current draw	[A]	see page 19
Extend / retract input voltage	[Vdc]	
HD12(24)		9 - 32
HD48		12 - 64
Extend / retract input current	[mA]	6 - 22

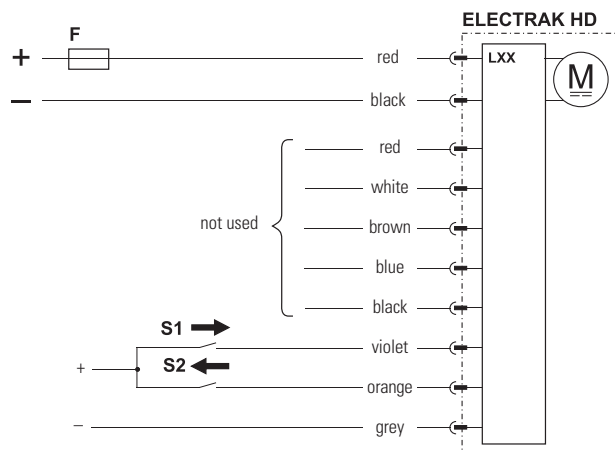
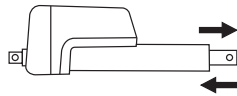

- F Fuse  
S1 Extend switch  
S2 Retract switch

Control option LXX has all the basic Electronic Monitoring Package features included in control option EXX, but the polarity of the motor voltage is switched by the onboard electronics instead. The customer-supplied switches used to command the actuator to extend or retract only need to handle low-level signals. However, the power supply and wiring that supply the actuator must be able to handle the motor current for the actuator model and load being used, as well as the inrush current (up to one and a half times the max. continuous current for the max. load being used for up to 150 milliseconds).

### Control Option Type LLX

Actuator supply voltage	[Vdc]	
HD12		9 - 16
HD24		18 - 32
HD48		36 - 64
Actuator current draw	[A]	see page 19
Output contact type		potential free
Limit switch max. switch voltage	[Vdc/ac]	30/120
Limit switch max. switch current	[mA]	100
Extend / retract input voltage	[Vdc]	
HD12(24)		9 - 32
HD48		12 - 64
Extend / retract input current	[mA]	6 - 22

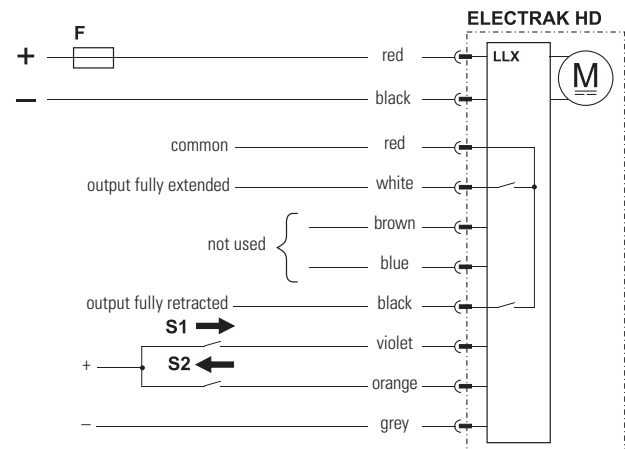
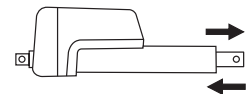

- F Fuse  
S1 Extend switch  
S2 Retract switch

Control option LLX works as option LXX but also has two outputs that indicate when the extension tube is in its fully extended or retracted position.



# Control Options

## Control Option Type LXP

Actuator supply voltage	[Vdc]	
HD12		9 - 16
HD24		18 - 32
HD48		36 - 64
Actuator current draw	[A]	see page 19
Potentiometer type		wirewound
Potentiometer max. input voltage	[Vdc]	32
Potentiometer max. power	[W]	1
Potentiometer linearity	[%]	± 0.25
Potentiometer output resolution	[ohm/mm]	
50 - 100 mm stroke		65.6
150 - 250 mm stroke		32.8
300 - 500 mm stroke		19.7
550 - 1000 mm stroke		9.8
Extend / retract input voltage	[Vdc]	
HD12(24)		9 - 32
HD48		12 - 64
Extend / retract input current	[mA]	6 - 22

## Control Option Type LPS

Actuator supply voltage	[Vdc]	
HD12		9 - 16
HD24		18 - 32
HD48		-
Actuator current draw	[A]	see page 19
Signal-follower input voltage	[Vdc]	0.5 - 4.5
Signal-follower max. output current	[A]	0.8
Signal-follower movement	[mm/Vdc]	stroke* [mm] / 4
Signal-follower repeatability	[± mm]	0.1
Programming inputs voltage	[Vdc]	
HD12(24)		9 - 32
HD48		-
Extend / retract input voltage	[Vdc]	
HD12(24)		9 - 32
HD48		-
Extend / retract input current	[mA]	6 - 22

\* ordering stroke of the actuator or the stroke between any set programmable extend or retract limits.

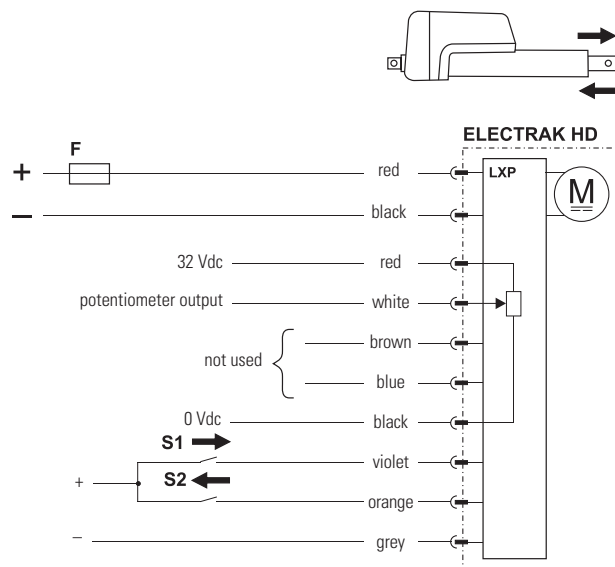

- F Fuse
- S1 Extend switch
- S2 Retract switch

Control option LXP works as option LXX but also has an analog (potentiometer) output that will provide feedback on the extension tube position.

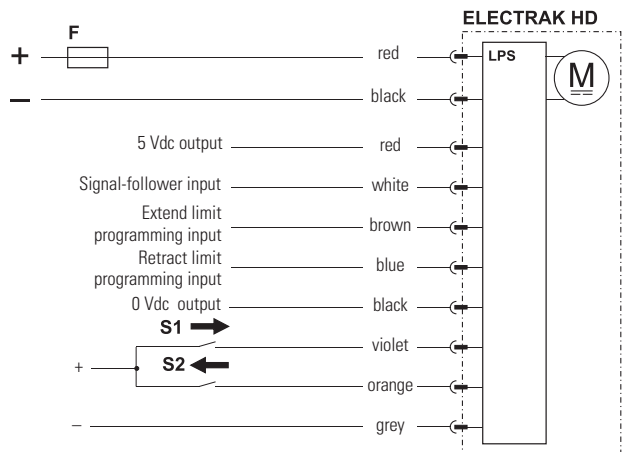
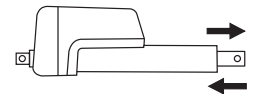

- F Fuse
- S1 Extend switch
- S2 Retract switch

Control option LPS works as option LXX but also has programmable mid-stroke software extend and retract limits as well as a signal-follower input that allows the extension tube position to be controlled from a potentiometer or other voltage control. Both functions can be used at the same time.

# Control Options

Control Option Type SY2		
Actuator supply voltage	[Vdc]	
HD12		9 - 16
HD24		18 - 32
HD48		36 - 64
Actuator current draw	[A]	see page 19
Extend / retract input voltage	[Vdc]	
HD12(24)		9 - 32
HD48		12 - 64
Extend / retract input current	[mA]	6 - 22
Number of synchronized actuators		2 - 8
Max. actuator speed difference	[%]	25
Hold and wait distance	[mm]	
HDxx-B017		25.0
HDxx-B026		15.0
HDxx-B045		10.0
HDxx-B068		7.5
HDxx-B100		5.0
HDxx-B160		2.5

Control option SY2 works as option LXX but also has a synchronization feature, allowing up to eight actuators having the SY2 option to run in integrated motion. When using the low-level extend and retract inputs on the master actuator, the receiver(s) will follow. If there is a need to run an actuator individually, it is possible to put it into an override state by closing a switch (S3) connected to the red lead as shown in the wiring diagram.

### Important design notes:

- All actuators' supply voltages must be within  $\pm 10\%$  of each other.
- While uneven loads can be supported, it is suggested that loads be distributed as evenly as possible to avoid overloading a single actuator within the system.
- The speed of the actuators will typically remain close to the speed they are rated for at full load, even if running at a lower load.
- If a unit detects that it is 1 mm further ahead of any other in the network, it will reduce its speed slightly to allow the other to catch up. If the positional difference between an actuator and the rearmost actuator exceeds the hold and wait distance specified in the table above, the unit will stop until the rearmost actuator catches up.
- If one actuator encounters an overload condition or detects that the measured position isn't updating while running the motor, it will trip the overload protection and send a signal to each actuator on the network to stop. The units can be immediately reversed (unless they bind up the system), or they can continue in the same direction after a power reset.

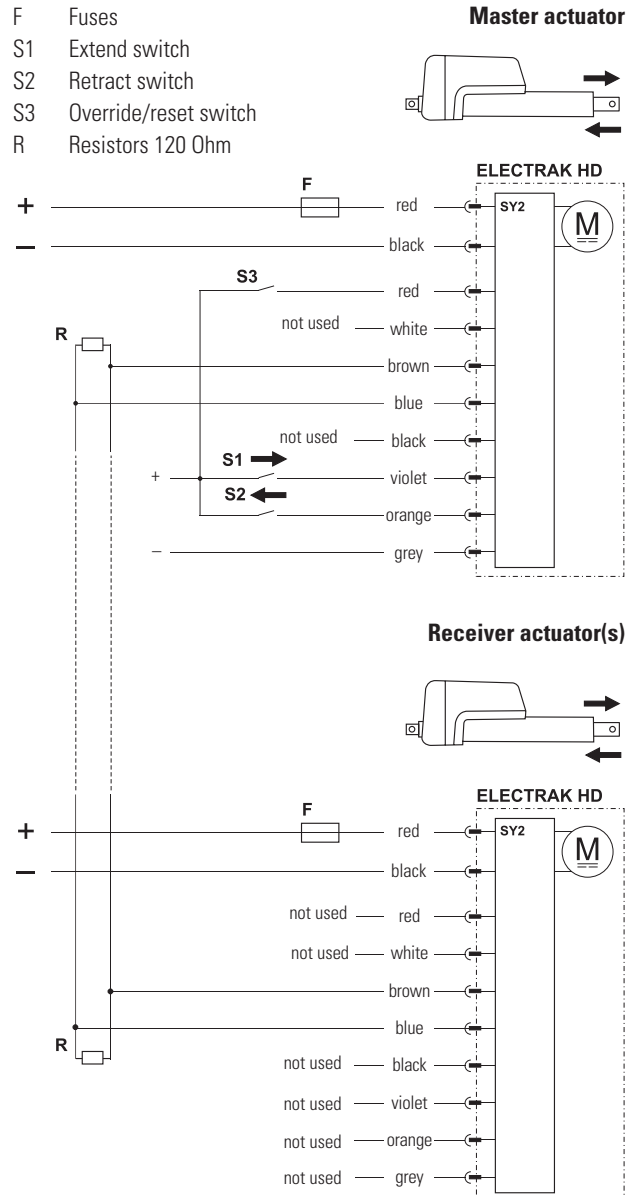

- Each actuator tracks the total number of actuators that are connected to the system. No synchronous motion will be allowed if any actuator detects that fewer than the minimum number of required actuators are connected. This allows the whole system to stop if the power or communication is lost to any actuator in the system.
- Activating the override/reset signal on any of the actuators will reset the minimum number of required actuators that must be connected to the system to 0. If more actuators are connected at any point, the minimum number of required actuators will be updated to the number of actuators that are currently connected.
- In order to give the master and receiver(s) enough time to communicate, a 250 ms delay will be enforced following any motion and before any subsequent motion is allowed.



# Control Options

## Control Option Type CNO and COO

Actuator supply voltage	[Vdc]	
HD12		9 - 16
HD24		18 - 32
HD48		36 - 64
Actuator current draw	[A]	see page 19
Command data includes:		
<ul style="list-style-type: none"> <li>• position</li> <li>• speed</li> <li>• current</li> </ul>		
Feedback data includes:		
<ul style="list-style-type: none"> <li>• position</li> <li>• speed</li> <li>• current</li> <li>• other diagnostic information</li> </ul>		
Extend / retract input voltage	[Vdc]	
HD12(24)		9 - 32
HD48		12 - 64
Extend / retract input current	[mA]	6 - 22

Address select 1, 2 and 3 pins can be used as a binary encoded decimal (BCD) adder to the default address. This can be used when multiple CAN bus actuators are located on a single bus. The actuator can be manually forced to extend or retract by using the inputs on white and black wires. When the manual control inputs are used, CAN bus control messages are ignored, but the unit will still provide CAN bus feedback messages. When the inputs are left floating, CAN bus functionality for control messages is restored.

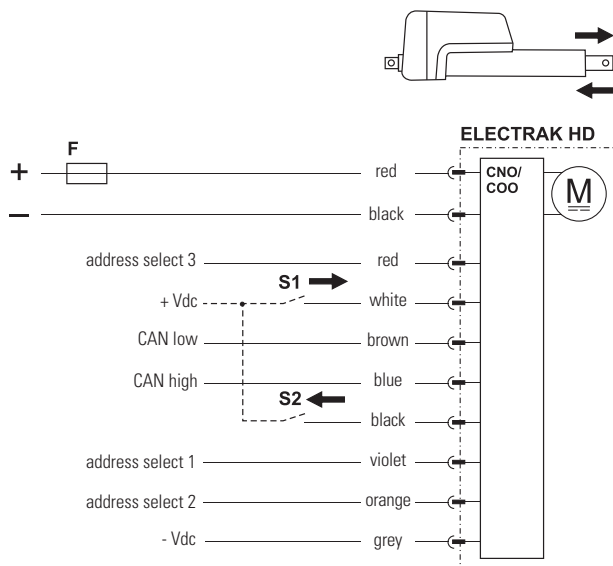

- F Fuse
- S1 Manual extension switch (optional)
- S2 Manual retraction switch (optional)

Control option CNO has a SAE J1939 CAN bus control interface, COO has a CANopen control interface that control and monitor the actuator. Extend and retract commands are sent via CAN messages on the CAN low and CAN high pins.

## Accessories

### Limit Switches for Cover Tube Mounting

Sensor type	solid state	reed switch
Contact type	normally open (N.O.)	
Output type	PNP	contact
Voltage [VDC/AC]	10 - 30 / -	5 -120 / 5 -120
Max. current [mA]	100	
Hysteresis [mm]	1.5	1.0
Operating temperature [°C]	- 25 to + 85	- 25 to + 70
Lead cross section [mm <sup>2</sup> ]	3 × 0.14	2 × 0.14
Length (L) [mm]	25.3	30.5
Height (H) [mm]	5.1	5.7
Protection class	IP69K	IP67
LED indicator	yes	
Connection	2 m cable with flying leads	
p/n	840-9131	840-9132

### Mounting positions

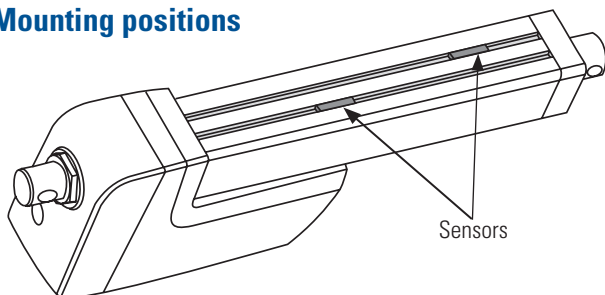

### Dimensions [mm]

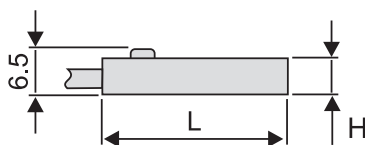

### Connection

Solid state

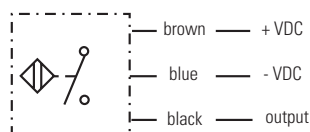

Reed switch

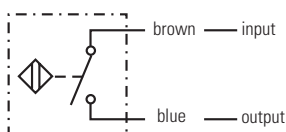

The limit switches are mounted in the cover tube slots and will be switched by a magnet mounted inside of the actuator on the extension tube.

### Rod End Front Adapter

Type	metric	inch
Material	Cadmium-plated steel	
Dimensions		
A	12.0 ± 0.1 mm	0.5 in
B	14.3 ± 0.1 mm	0.625 in
C	M12	1/2-20 UNF
p/n	756-9021	756-9007

### Dimensions [mm (in)]

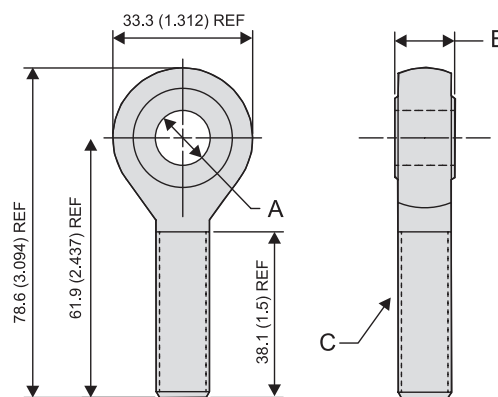

The rod end front adapter comes in a metric or inch version. The metric adapter can be mounted to the front of the extension tube if the actuator is equipped with the metric female thread front adapter option (type P), while the inch adapter requires the inch female thread option (type G).

### Wire Harness Kits

Part Number	Description
954-9364	0.3 m Power Only (EXX)
954-9365	1.5 m Power Only (EXX)
954-9366	5.0 m Power Only (EXX)
954-9367	0.3 m Power and 8-Wire Signal (ELX, ELP, ELD, LXX, LLX, LXP, CNO, COO, SY2)
954-9368	1.5 m Power and 8-Wire Signal (ELX, ELP, ELD, LXX, LLX, LXP, CNO, COO, SY2)
954-9369	5.0 m Power and 8-Wire Signal (ELX, ELP, ELD, LXX, LLX, LXP, CNO, COO, SY2)
954-9370	0.3 m Power and 3-Wire Signal (EXP, EXD)
954-9371	1.5 m Power and 3-Wire Signal (EXP, EXD)
954-9372	5.0 m Power and 3-Wire Signal (EXP, EXD)



## Customization

Can't find what you need for your application's design requirements? Experienced Thomson engineers are ready to work alongside you to find your optimal custom solution. From a small modification to a unique, white paper design that perfectly matches your needs, we are your trusted partner.

Thomson has been providing custom actuator solutions for decades. We have an extensive library of modifications that we can apply, ranging from surface treatments to custom strokes or supply voltage.

### Controls or Software

Integrating custom controls and/or software instead of changing the physical size/properties of the actuator is often an easier means to enhance its intelligence.

### Voltage

Custom supply voltages are a common actuator modification.

### Manual Override

Modifications to the override input are possible.

### Electrical Connections

Special cables, connectors or custom harnesses can be added to match your application requirements.

### Speed or Force

Custom gears can alter the speed and/or force of the actuator to suit the application.

### Ingress Protection

Custom sealings, gaskets, bellows and other design solutions can be provided to bolster protection from the elements.

### Stroke

Stroke length is a common and easily done customization.

### Surface Treatment

Thomson can provide a custom color, coating or other special surface treatment to the Electrak® HD.

### Sensors and Switches

Pre-mounting both internal and external sensors at the factory can save you significant time.

### Adapters

Both front and rear adapters can be customized to fit your application to help the actuator fit into a given mounting position.

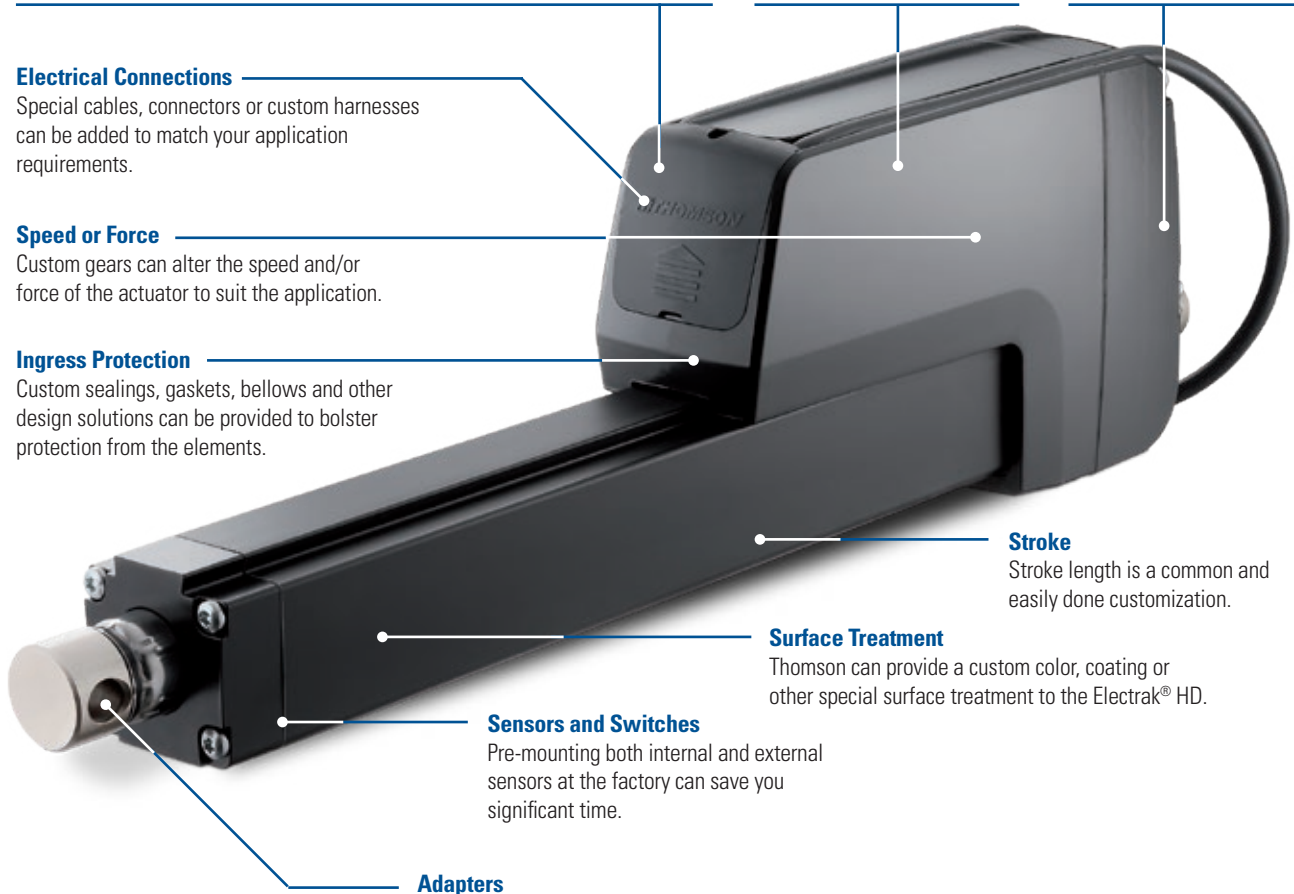

## Online Resources

Thomson offers a wide variety of online application, sizing and training tools to help you in the selection process. An experienced team of application engineers is also available to help you find an Electrak® HD model to best fit your application needs. To explore additional technical resources and options, contact Thomson customer support at [www.thomsonlinear.com/hd](http://www.thomsonlinear.com/hd).

### Linear Actuators on the Web

Find additional information and learn more about electric linear actuators on this content-rich web page. [www.thomsonlinear.com/en/products/linear-actuators#overview](http://www.thomsonlinear.com/en/products/linear-actuators#overview)

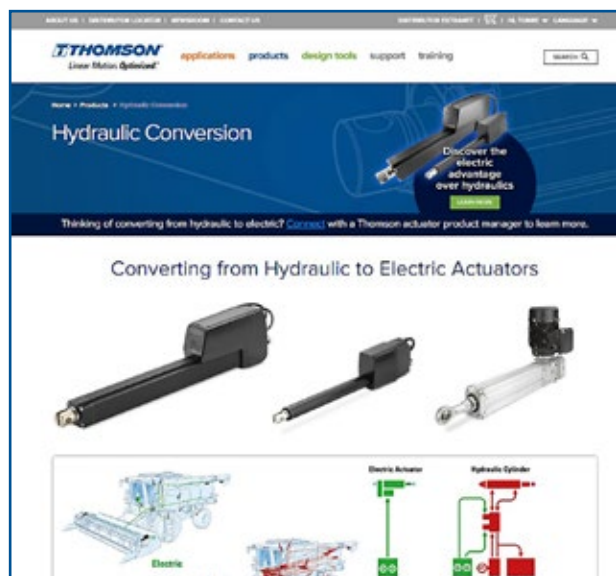
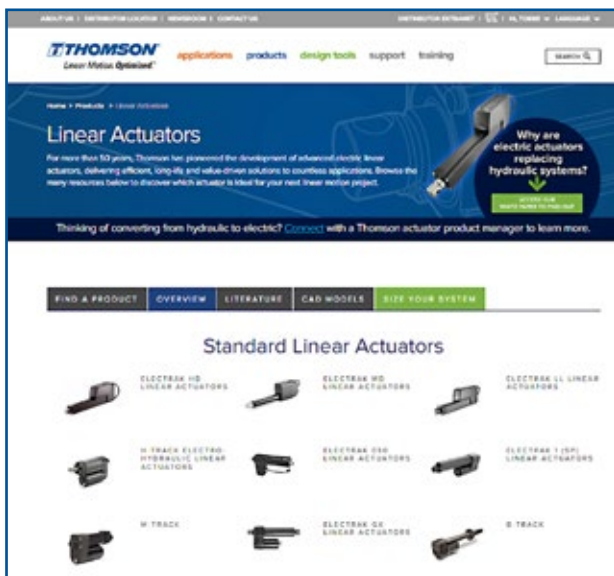

### Linear Actuator Selector Tool

The product selector will walk you through the selection process. [www.thomsonlinear.com/en/products/linear-actuators-products](http://www.thomsonlinear.com/en/products/linear-actuators-products)

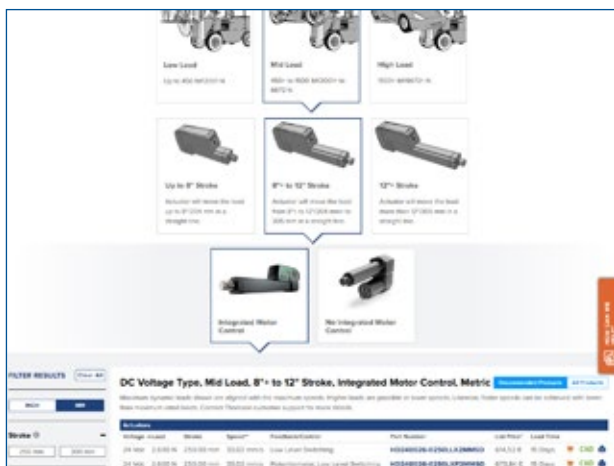

### Interactive 3D CAD Models

Download free interactive 3D CAD models in the most common CAD formats. [www.thomsonlinear.com/micro/electrakhd\\_eng/3d-model-downloads.html](http://www.thomsonlinear.com/micro/electrakhd_eng/3d-model-downloads.html)

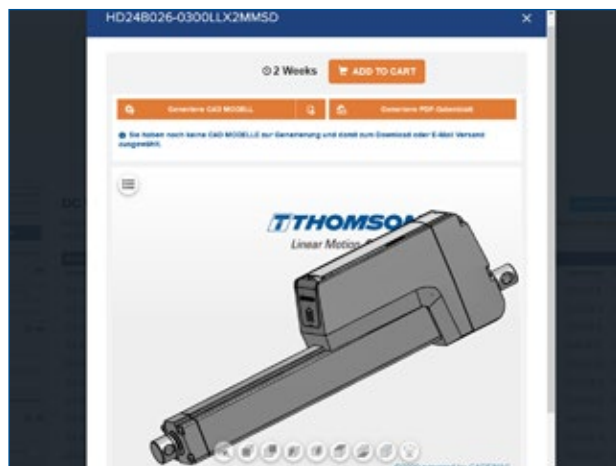



## Frequently Asked Questions

Here are answers to common questions we receive. If you need more information, please contact customer support at [www.thomsonlinear.com/cs](http://www.thomsonlinear.com/cs).

### What is the typical life of an actuator?

Life is a function of load and stroke length. Please contact customer support for more information.

### What are the most common reasons for premature actuator failure?

Side load due to incorrect mounting, shock loading, exceeding the duty cycle and incorrect wiring are the most prominent causes for premature failure.

### What are IP ratings?

International Protection Marking (IP) ratings are commonly referenced standards that classify electrical equipment using standard tests to determine resistance to ingress of solid objects (first digit) and liquids (second digit). See the IP Ratings table below.

### Is Electrak HD suitable for tough environments such as washdown or extreme temperatures?

Yes. Electrak HD actuators are designed for washdown and have passed 500 hours of salt spray tests. They can operate in temperatures ranging from -40°C (-40°F) to +85°C (185°F).

### How is the duty cycle determined?

Duty cycle = on time / on time + off time. For example, if Electrak HD is powered for 15 seconds and then off for 45 seconds, the duty cycle for that minute would be 25%. All models are rated to 25% at full load, and an ambient temperature of 25°C (77°F). If load and/or ambient temperature are lower, then the duty cycle can exceed 25%. At higher temperatures, the duty cycle will be lower.

IP Rating (EN60529)		
Code	First Digit Definition	Second Digit Definition
0	No protection.	No protection.
1	Protected against solid objects over 50 mm.	Protected against vertically falling drops of water.
2	Protected against solid objects over 12.5 mm.	Protected against vertically falling drops of water, if the case is disposed up to 15° from vertical
3	Protected against solid objects over 2.5 mm.	Protected against vertically falling drops of water, if the case is disposed up to 60° from vertical
4	Protected against solid objects over 1 mm.	Protected against splash water from any direction.
5	Limited protection against dust ingress (no harmful deposits).	Protected against low-pressure water jets from any direction. Limited ingress permitted.
6	Totally dust protected.	Protected against high-pressure water jets from any direction. Limited ingress permitted.
7	–	Protected against short periods of immersion in water.
8	–	Protected against long, durable periods of immersion in water.
9K	–	Protected against close-range, high-pressure and high-temperature spray downs.

### Is Electrak HD maintenance free?

Yes. Electrak HD never requires lubrication, maintenance or adjustment for wear.

### Is it possible for a load to back-drive the extension tube?

No. The ball screw models incorporate a static load holding brake.

### What is the difference between a tension and a compression load?

A tension load tries to stretch the actuator, while a compression load tries to compress it. With bi-directional loads, the end play of the actuator extension tube may need to be taken into consideration when using the actuator for positioning tasks.

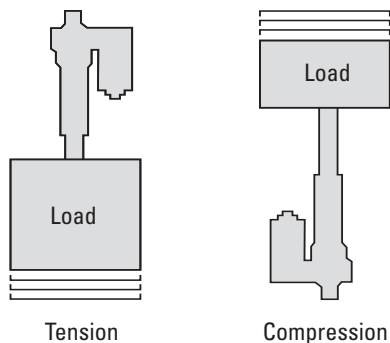

### Can Electrak HD be side loaded?

No. A proper design of the application should eliminate any side loads.

### What is the range of input voltage an Electrak HD can operate with?

A 12 Vdc model will accept 9 – 16 Vdc, a 24 Vdc model 18 – 32 Vdc and a 48 Vdc model 36 – 64 Vdc. Outside of these limits, the Electronic Monitoring Package will prevent the actuator from operating.

### Can the speed of an Electrak HD be adjusted by changing the input voltage?

No. When using direct current from a battery or full wave rectifier that are within the acceptable voltage limits, the Electronic Monitoring Package will keep the actuator at the correct speed for the load in question. Outside of the limits, the actuator will be switched off. If utilizing Pulse Width Modulation (PWM) controls or drives, the actuator PCB can be damaged and is therefore not recommended.

### What is the inrush current?

The inrush current is a short current peak that appears at the start of an actuator as the motor tries to get the load moving. Typically, the inrush current will last between 75 to 150 milliseconds and can be up to three times higher (1.5 times higher on a low-level switched actuator) than the current for the actuator and load. Batteries have no problem delivering the inrush current, but if using an AC-powered power supply, it is important to size it to handle the inrush current.

### What special mounting considerations does the Electrak HD require?

There is no restraining torque that needs to be considered as Electrak HD is internally restrained. However, the actuator must be mounted so that there are no side loads acting on the extension tube. It is also important that the manual override input is accessible after the actuator is mounted and that connectors and cables are placed so that they are not damaged during operation.

### What is the maximum extension speed?

The extension speed of an Electrak HD actuator is a function of the load. To determine the speed at a certain load, consult the load vs. speed charts on page 21. If a higher linear travel speed is required, a simple mechanical linkage can be employed.

Contact us or any of our 2000+ global distribution partners by scanning the code below  
or visiting [www.thomsonlinear.com/contact](http://www.thomsonlinear.com/contact)



**RegalRexnord™**

[www.regalrexnord.com](http://www.regalrexnord.com)

[www.thomsonlinear.com](http://www.thomsonlinear.com)

Electrak\_HD\_Actuator\_BREN-0020-27 | 20260217KB | MCB-12354-TL-EN-US  
Specifications are subject to change without notice. It is the responsibility of the product user to determine the suitability of this product for a specific application. All trademarks property of their respective owners. ©2026 Thomson Industries, Inc. | 2400 Curtiss Street, Downers Grove, IL 60515 USA

**THOMSON®**