

NEW OPTIONS

*Controls, Supply Voltages
and Higher Speeds*



Electrak[®] LL

Long Life, High Duty Cycle Actuator
with Superior Environmental Protection



Electrak[®] LL – Long Life, High Duty Cycle Linear Actuator

Finding an affordable electric linear actuator with long life, high duty cycle and the ability to work in the harshest environments has been difficult for design engineers. With the new Electrak LL, the search is over, and new markets and applications have been opened for electric actuators.

Long Maintenance-Free Life

In order to make long life and no maintenance the top priorities for Electrak LL, Thomson's engineering team closely examined every function and component to develop the necessary improvements upon its predecessors.

- **NEW!** Additional control options including bus communications (CANopen[®] or SAE J1939) and non-contact absolute position sensor
- **NEW!** Higher speed option for lighter loads
- **NEW!** Option for 48 Vdc supply voltage
- Efficient, long-life brushless motor
- Built-in, brushless motor drive system
- Specially designed onboard controls, meeting railway safety standards*
- Long-life ball screw and nut assembly
- Long-life, load-bearing design
- Long-life, manual override design
- UV-resistant surface treatment
- Thomson's full Electronic Monitoring Package functionality
- All stainless steel external hardware

High Duty Cycle

The full load duty cycle for Electrak LL is 35%, and up to 100% at reduced load, which is significantly higher than comparable actuators. The combination of higher duty cycle and longer life makes Electrak LL well suited for many applications - most notably mobile battery powered ones - that previously have had to employ more expensive and complex solutions. Examples include:

- Pantograph control
- Lifting and positioning in mobile equipment
- Door, hatch and valve control
- Picking, placing and sorting
- Material handling
- AGV applications
- Conveyor control

* Electrak LL (24 Vdc version only) complies to the railway standards EN 50155, EN 60077 and EN 4554.

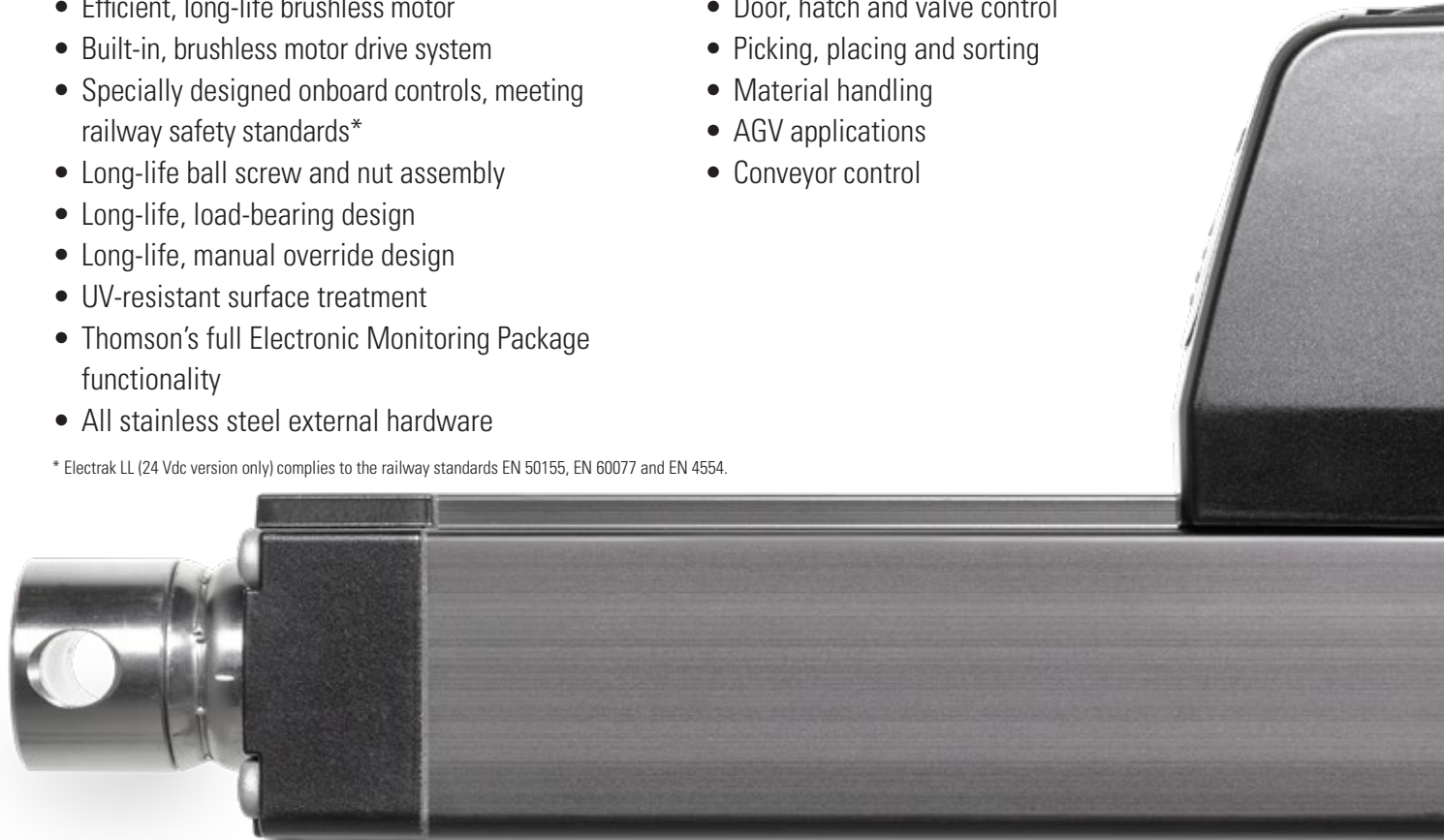

Superior Environmental Protection

Electrak LL takes environmental protection to the next level, offering outstanding protection against dirt, chemicals and elements of nature.

- IP69K (static) and IP66 (static and dynamic) ratings prove Electrak LL can withstand the harshest environments
- Capable of operating in a wide temperature range from -40°C to +85°C (-40°F to +185°F)
- Salt spray tested for 500 hours
- CE, RoHS and REACH (EU) compliant
- Rated for IP-X6 (dynamic) during water splash at +10°C (+50°F) and an equalized actuator temperature of +85°C (+185°F)
- Solar radiation (UV) tested for 300 hours according to IEC 60068-2-5

Replacing Pneumatic or Fluid Power

Electrak LL's multitude of capabilities opens up new application opportunities where electric linear actuators can replace pneumatic and hydraulic cylinders. This results in benefits such as:

- Better controllability and feedback capabilities
- Space-saving designs
- Simplified engineering and installation
- Less energy usage leading to improved efficiency
- Cleaner and more environment friendly
- Little to no maintenance required





Thrives in Places Where Most Actuators Give Up

Electrak[®] LL was specially designed to ensure long and trouble-free operation in the toughest applications. Even by Thomson standards, Electrak LL stands out in this respect, and it will keep working where most other electric linear actuators bow out.

Thomson engineers have labored and scrutinized over the smallest of details to ensure that all Electrak LL parts meets the strictest environmental demands. The

result is a heavy duty actuator that can ensure up to 600 km (375 miles) of trouble-free duty in some of the worst conditions imaginable.

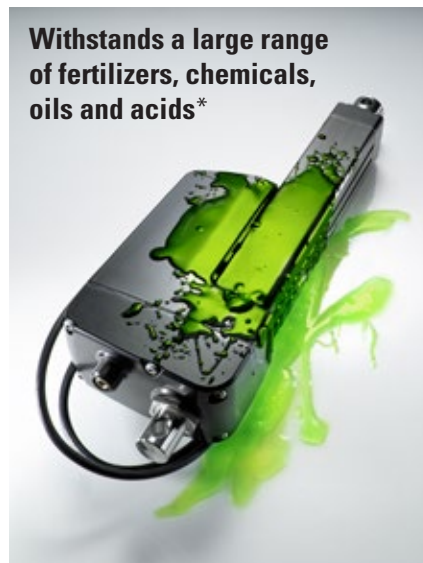

* Contact customer support for information on the resistance for specific substances

Travels Further at a Faster Pace

Not only is Electrak LL tough, but it is tenacious as well. With a life of up to 600 km and a duty cycle of up to 100%, these actuators can work longer and at a higher frequency than previous generations of actuators. This makes them ideal in applications where, if you were previously using a traditional electric actuator, you had to settle for shorter life and more maintenance, or turn to a more complex, expensive and bulkier pneumatic or hydraulic system.

Electrak linear actuators deliver many benefits, but they also carry some inherent limitations. Often these are related to the life and/or duty cycle of the actuators, which force engineers to opt for a pneumatic or hydraulic solution despite their many drawbacks. Now with its improved life and duty cycle, Electrak LL offers the full gamut of benefits and is equipped to tackle applications once thought impossible for electric actuators.

Longer Life

The theoretical maximum travel life of an Electrak LL actuator is 600 km (375 miles), which is more than 10 times longer than comparable actuators capable of the same load and speed. In order to calculate an exact as possible life expectancy for an actuator in a specific application, many more variables must be taken into account. Please contact Thomson customer support for assistance with these calculations.

Higher Duty Cycle

The Electrak LL full load duty cycle is 35%, which is 10 – 20% higher than for other comparable electric linear actuators, and at reduced load it can go up to 100%. That translates into more work done in a given timeframe without having to use forced cooling or a stronger and bigger actuator than the load requires just to avoid overheating.

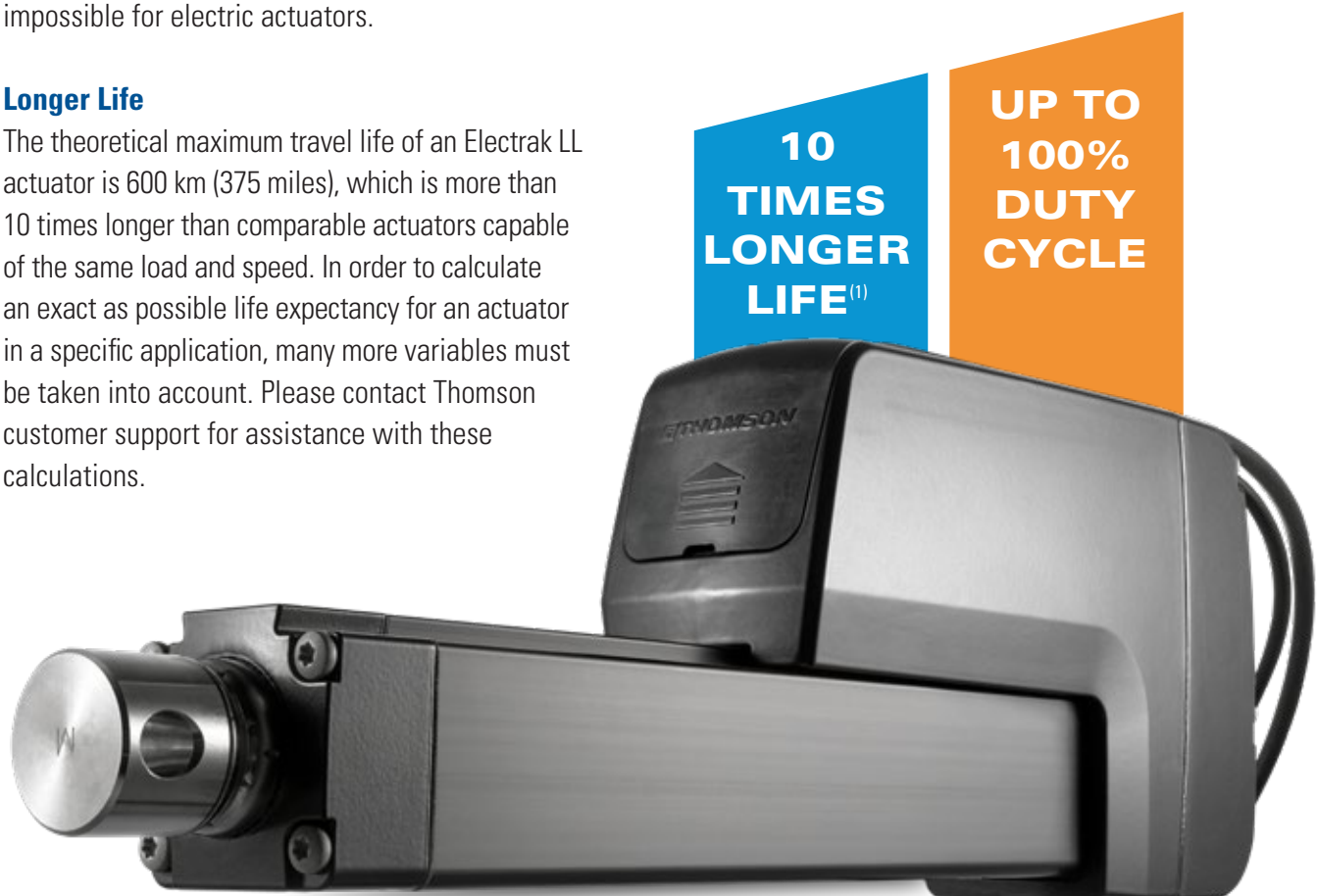

¹ Compared to an electric linear actuator of comparable size, type and load/speed performance.



A Look Inside the Thomson Electrak® LL

What makes Electrak LL tick? In short, it is decades of accumulated electric actuator knowledge combined with state-of-the-art technologies, high-quality components and thorough testing done both in the lab and in the field.

LONGER LIFE

The best materials and the use of cutting-edge technologies deliver long and trouble-free life.

- 1 **Brushless DC motor with electromagnetic brake**
- 2 **New control board with tougher components**
- 3 **Longer life screw and nut assembly**
- 4 **New long-life, load-bearing design**
- 5 **New more robust manual override design**

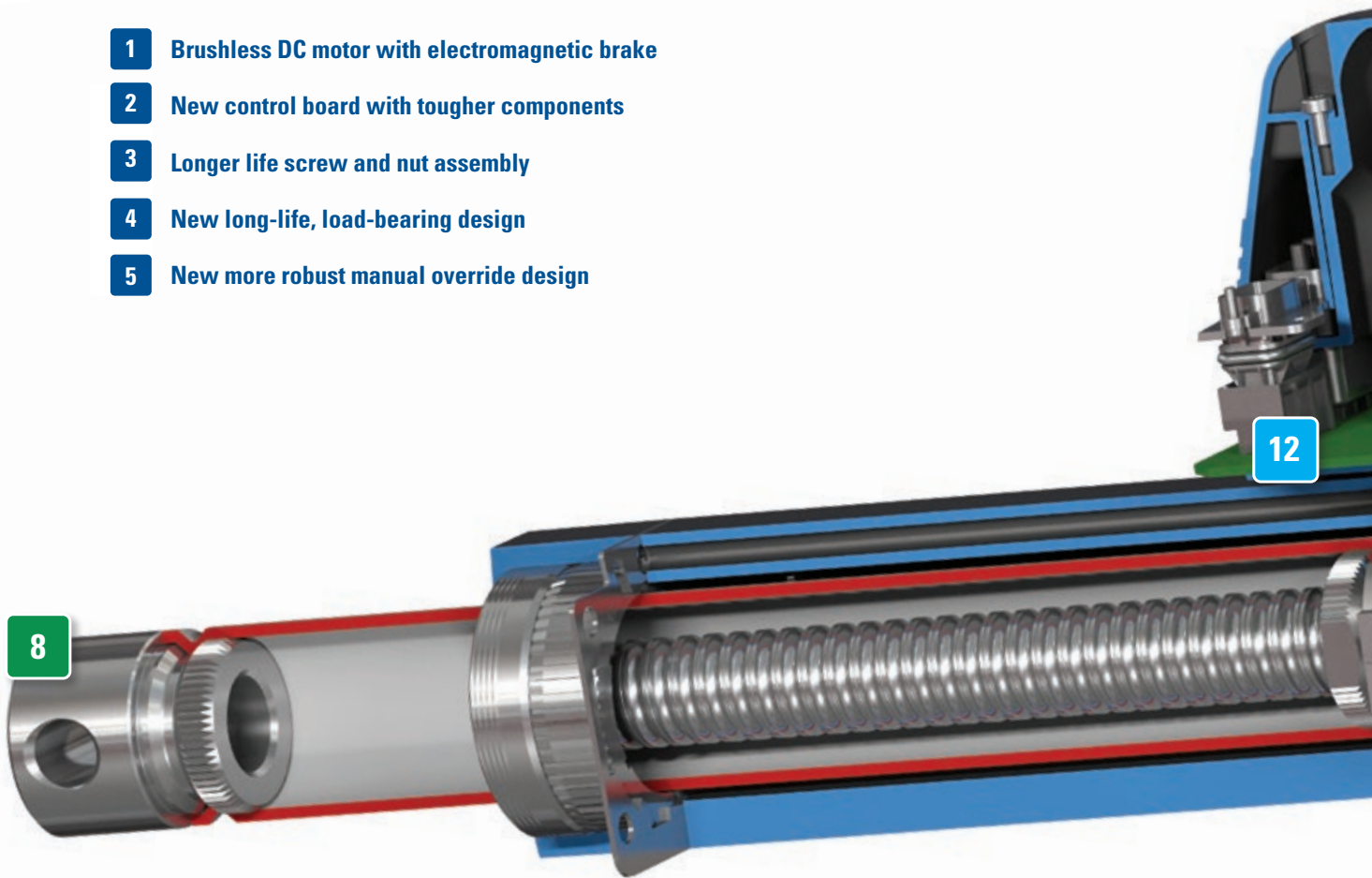

HIGHER DUTY CYCLE

Lower-friction components and a more efficient motor results in smoother operation and a higher duty cycle.

- 6 **More efficient motor and control**
- 7 **Higher quality screw and nut**

UPGRADED ENVIRONMENTAL PROTECTION

Tougher exterior hardware and improved surface treatment reduce the impact of the elements.

- 8 **Stainless steel adapters**
- 9 **Stainless steel hardware**
- 10 **Better UV-resistant surface treatment**
- 11 **Flame-retardant, halogen-free cables**

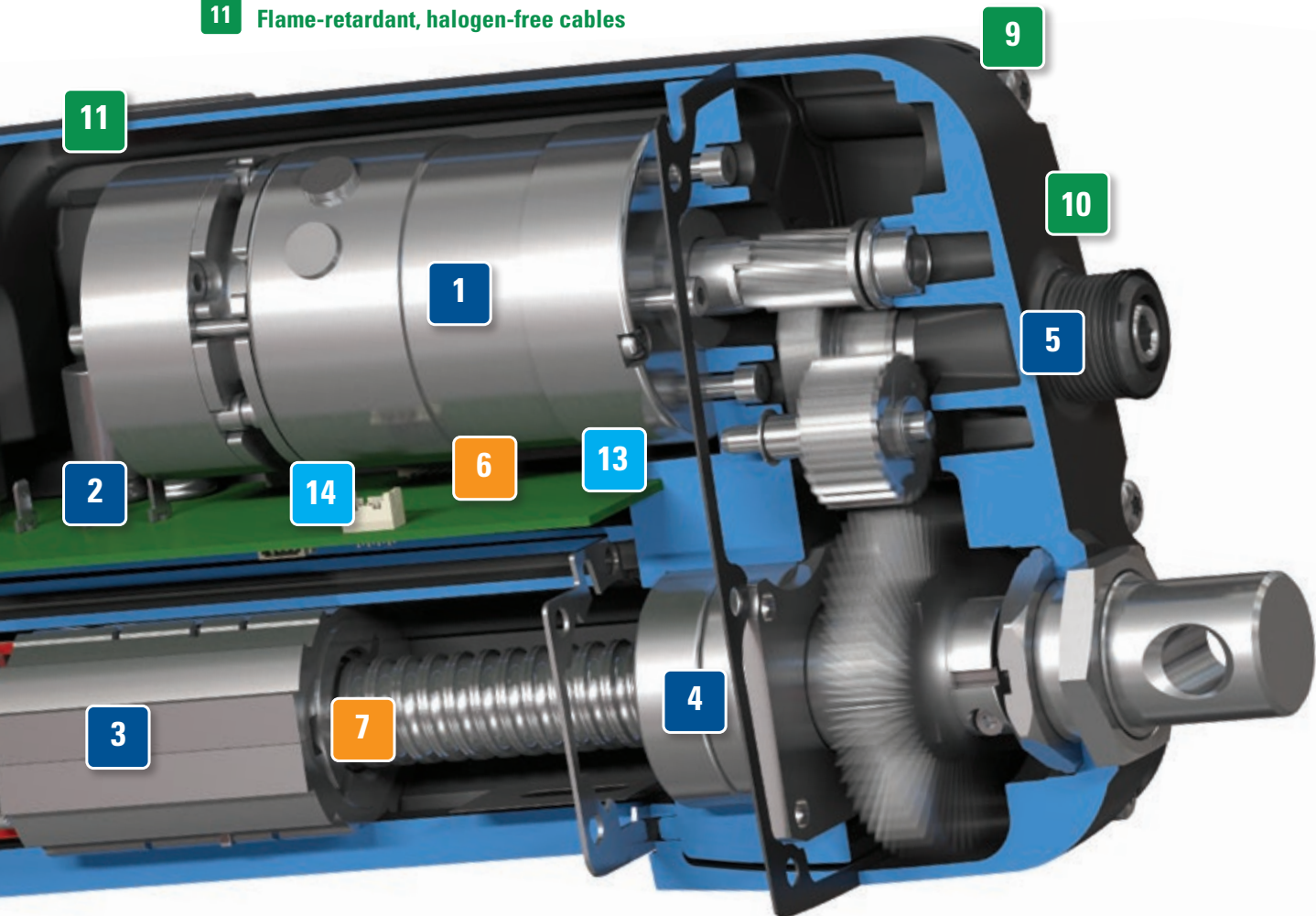

BETTER CONTROLLABILITY

Smart onboard controls open new possibilities and reduce engineering time.

- 12 **Built-in low-level switching**
- 13 **Control options with non-contact absolute position feedback sensor**
- 14 **Bus communication options (CANopen® or SAE J1939)**



Ready for the Railway

Electrak[®] LL was designed with the railway market in mind. The standards and safety regulations for railway equipment can be very demanding and require rigorous testing to ensure compliance.

Railroad equipment is exposed to some of the toughest conditions. The Electrak LL actuator performs effectively despite harsh weather, heavy vibrations or high-pressure washing, making it ideal for opening and closing gravity bins or controlling a pantograph.

Railway Standards

The railway industry has its own safety standards* and regulations for components and equipment used for critical operations. Electrak LL complies to the following railway standards:

- EN 50155
- EN 60077
- EN 45545

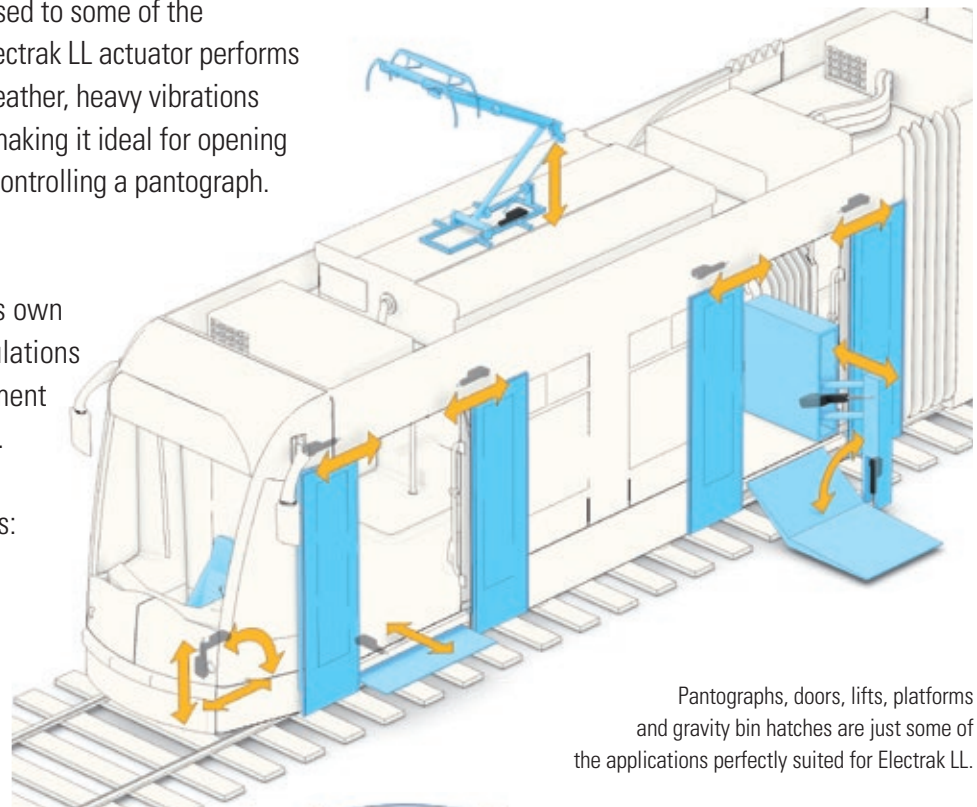

* Electrak LL (24 Vdc version only) complies to the railway standards EN 50155, EN 60077 and EN 4554.

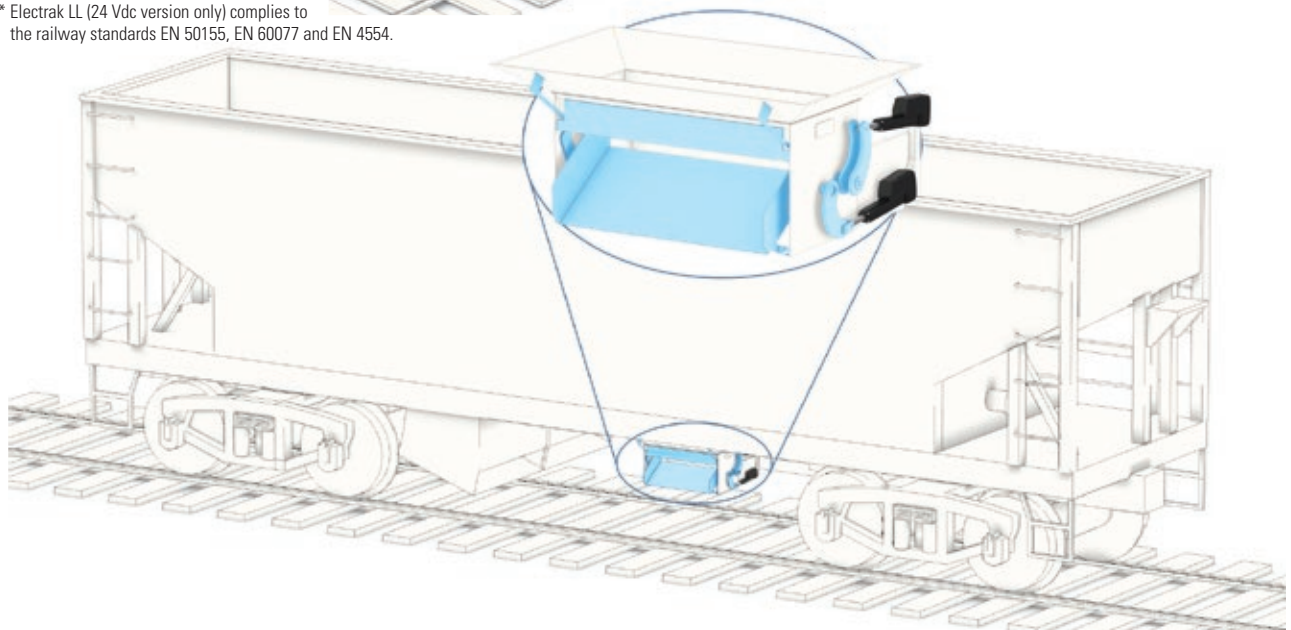

The Long Life Advantage

The long life of Electrak LL enables it to take on applications where before it may have been difficult or impossible to use electric linear actuators due to life expectancy constraints. This advantage is especially true for industrial applications where equipment is often put to work around the clock without any breaks.

Typical electric linear actuator applications have traditionally been those for low-frequency setup and adjustment operations since, in many cases, life may have been the limiting factor. Therefore, the only solution has been to upgrade to more expensive actuators that deliver higher overall performance. With life being the only improvement really needed though, the unfortunate result has been an over-performing and over-priced solution. Electrak LL now closes that gap, giving you the opportunity to realize long, reliable life at a reasonable cost for medium-frequency tasks.

Logistics and Material Handling

There are many industrial applications for which Electrak LL provides an ideal solution, but where it really excels are in applications in which medium-frequency work is done on a daily basis. Examples

are lifting, tilting and grabbing operations in AGVs, logistic trains and lift trucks, or in material handling machines operating a valve, hatch or cutter back and forth during a production cycle. Often these types of operations also require multiple actuators sharing the load, which can be a challenge due to uneven loads and resulting binding effects. With Electrak LL, it is an easier task since its speed is load independent and therefore constant.

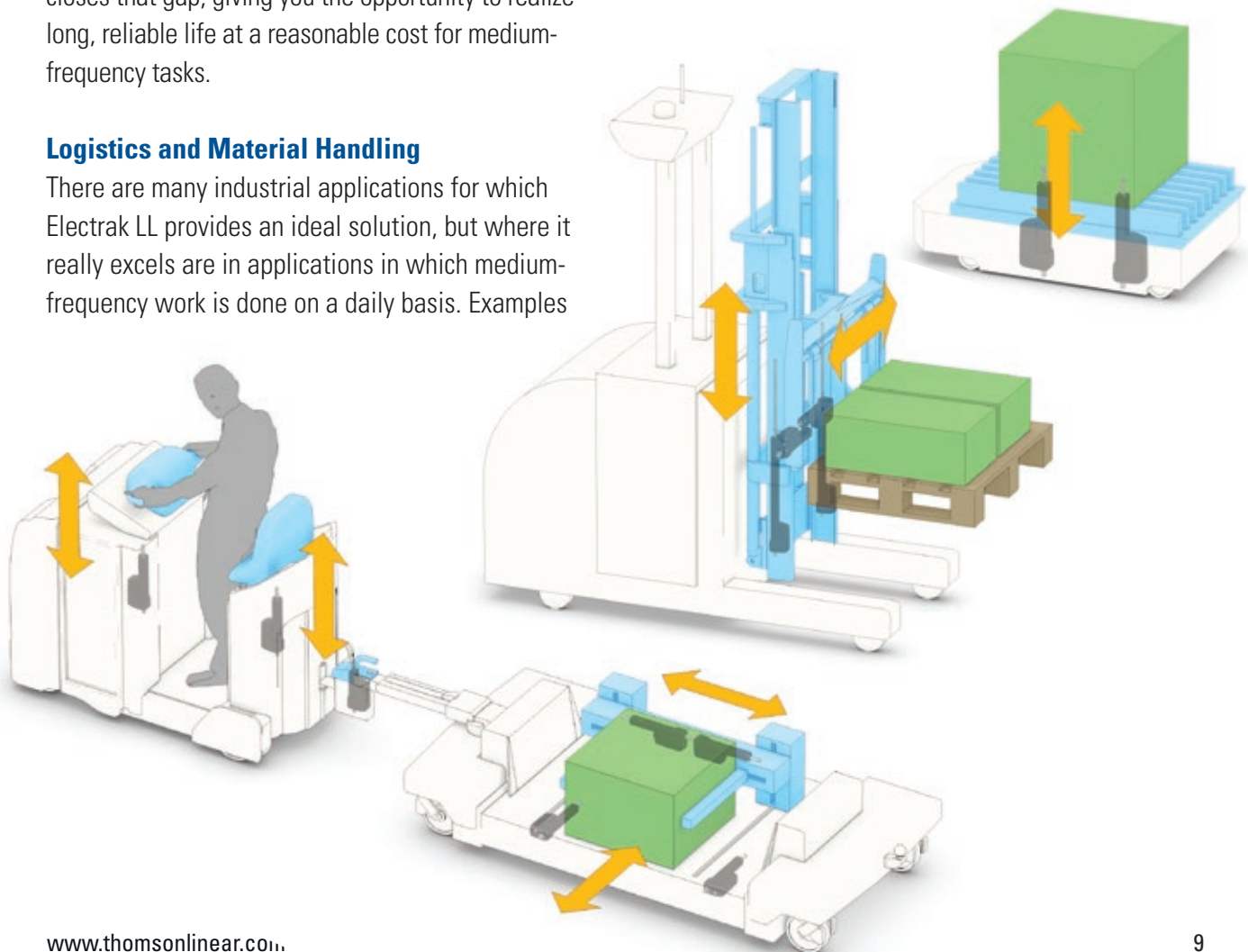



Electrak® LL Technical Features



Electrak LL - The Long Life Actuator

- Long life expectancy
- High duty cycle
- Constant speed regardless of the load
- Designed and tested to meet the toughest environmental demands
- 24 Vdc versions complies to railway standards EN 50155, EN 60077 and EN 45545 *
- Onboard electronics eliminate the need for standalone controls
- Suitable for pneumatic and hydraulic-to-electric application conversions

* Electrak LL (24 Vdc version only) complies to the railway standards EN 50155, EN 60077 and EN 4554.

General Specifications

Screw type	ball
Nut type	load lock ball nut
Manual override	yes
Anti-rotation	yes
Controlled braking	yes ⁽¹⁾
Static load holding brake	yes
End-of-stroke protection	internal end-of-stroke limit switches
Overload protection	yes
Temperature monitoring	yes
Temperature compensation	yes
Voltage monitoring	yes
Electrical connections ⁽²⁾	cable(s) with flying leads
Electronic onboard controls	see control options table below
Compliances ⁽³⁾	CE, RoHS, EN 50155, EN 60077, EN 45545

(1) The actuator is stopped in a controlled manner using a preset deceleration rate.

(2) There are two cables. The cable(s) enters the actuator via a connector. The replacement of an actuator can be completed by unplugging the old actuator and plugging in the new one.

(3) Only the 24 Vdc versions complies to EN 50155, EN 60077 and EN 45545.

Mechanical Options

Mechanical options	Variety of front and rear adapters
	Alternative adapter orientation

Control Options

LEX	Electrak Monitoring Package + low-level signal motor switching + external end-off-stroke limit switch inputs
LXX	Electrak Monitoring Package + low-level signal motor switching
LXP	Electrak Monitoring Package + low-level signal motor switching + absolute position feedback output
CNO	SAE J1939 CAN bus + speed control
COO	CANopen CAN bus + speed control

Accessories

Mechanical	Rod end front adapter
Electrical	External slot-mounted limit switches

Electrak LL Technical Specifications

Mechanical Specifications

Max. static load ⁽¹⁾	[kN (lbs)]	
LLxx-B020		5 (1124)
LLxx-B040		10 (2248)
LLxx-B060		15 (3372)
Max. dynamic load (Fx)	[kN (lbs)]	
LLxx-B020		2 (450)
LLxx-B040		4 (899)
LLxx-B060		6 (1349)
Speed ⁽²⁾	[mm/s (in/s)]	
LLxx-B020		54 (2.13)
LLxx-B040		30 (1.18)
LLxx-B060		15 (0.59)
Min. ordering stroke (S) length	[mm]	100
Max. ordering stroke (S) length	[mm]	450
Ordering stroke length increments	[mm]	50
Operating temperature limits	[°C (F)]	-40 – 85 (-40 – 185)
Full load duty cycle @ 25 °C (77 °F)	[%]	35
End play, maximum	[mm (in)]	1.2 (0.047)
Restraining torque	[Nm (lbs)]	0
Protection class - static		IP66 / IP69K
Protection class - dynamic		IP66
Salt spray resistance	[h]	500

1) Max. static load at fully retracted stroke

2) Speeds are constant regardless of the load unless using the speed control feature in bus controlled units

3) Do not use PWM voltage for speed control to avoid damaging the onboard electronics

4) Control option LEX not available with 48 Vdc input voltage

Weight [kg]

Ordering Stroke (S) [mm]

100	150	200	250	300	350	400	450
6.8	7.2	7.5	7.9	8.2	8.6	8.9	9.3

Conversion Factors:

Millimeter to inch: 1 mm = 0.03937 in

Kilogram to pound: 1 kg = 2.204623 lbs

Electrical Specifications

Available input voltages ⁽³⁾⁽⁴⁾	[Vdc]	24, 48
Input voltage tolerance	[Vdc]	
LL24 (24 Vdc input voltage)		16.8 - 32.0
LL48 (48 Vdc input voltage)		36.0 - 60.0
Current draw @ no load/max. load	[A]	
LL24-B020(40)		2/10.50
LL24-B060		2/8.50
LL48-B020(40)		1/5.25
LL48-B060		1/4.25
Motor cable leads cross section	[mm ² (AWG)]	2 (14)
Signal cable leads cross section	[mm ² (AWG)]	0.5 (20)
Standard cable length (Ca1)	[m (in)]	0.3 (11.8)
Cable diameter (Ca2)	[mm (in)]	
motor cable		7.3 (0.29)
signal cable		6.6 (0.26)
Flying lead length (Ca3)	[mm (in)]	74 (2.9)
Stripped lead length (Ca4)	[mm (in)]	6 (0.25)

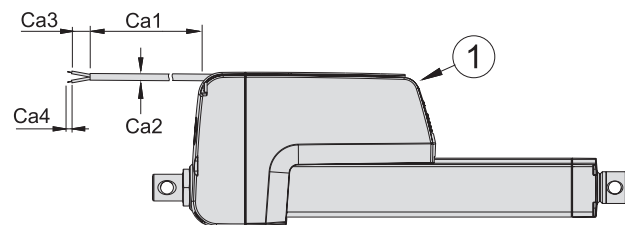

The drawing shows the cables exiting the cable slots at the end of the actuator housing, which is the shipping position. The user can adjust the exit point to be anywhere between the connector (1) in the front of the housing and the end of the cable slots.



How to Order the Electrak[®] LL

This ordering key provides a quick overview of the product versions available. It is important to consider many application details when selecting a product, including the loads, speeds and control options required, as well as the product environment and necessary accessories.

Ordering Key								
1	2	3	4	5	6	7	8	9
LL24	B040-	0200	LEX	A	S	S	S	D
<p>1. Model and input voltage LL24 = Electrak LL, 24 Vdc LL48 = Electrak LL, 48 Vdc</p> <p>2. Screw type, dynamic load capacity B020- = ball screw, 2 kN (450 lbs) B040- = ball screw, 4 kN (899 lbs) B060- = ball screw, 6 kN (1348 lbs)</p> <p>3. Ordering stroke length ⁽¹⁾ 0100 = 100 mm 0150 = 150 mm 0200 = 200 mm 0250 = 250 mm 0300 = 300 mm 0350 = 350 mm 0400 = 400 mm 0450 = 450 mm</p> <p>4. Control option LEX = Electrak Monitoring Package + low-level signal motor switching + external end-off-stroke limit switch inputs ⁽²⁾ LXX = Electrak Monitoring Package + low-level signal motor switching ⁽³⁾ LXP = LXX + absolute position feedback output ⁽³⁾ CNO = SAE J1939 CAN bus + speed control ⁽³⁾ COO = CANopen CAN bus + speed control ⁽³⁾</p> <p>5. Harness option A = 0.3 m long railway approved cables with flying leads (number coded leads) 1 = 0.3 m long halogen-free cables with flying leads (color coded leads) 2 = 1.5 m long halogen-free cables with flying leads (color coded leads) 3 = 5.0 m long halogen-free cables with flying leads (color coded leads)</p>					<p>6. Rear adapter option M = cross hole for 12 mm pin E = cross hole for 0.5 inch pin N = forked cross hole for 12 mm pin F = forked cross hole for 0.5 inch pin S = stainless cross hole for 12 mm pin T = stainless forked cross hole for 12 mm pin</p> <p>7. Front adapter option M = cross hole for 12 mm pin E = cross hole for 0.5 inch pin N = forked cross hole for 12 mm pin F = forked cross hole for 0.5 inch pin P = metric female thread M12 × 1.75 G = inch female thread 1/2-20 UNF-2B S = stainless cross hole for 12 mm pin Q = stainless metric male thread M16 × 2 R = stainless metric female thread M16 × 2 T = stainless forked cross hole for 12 mm pin</p> <p>8. Adapter orientation S = standard M = 90° turned</p> <p>9. Connector option D = flying leads</p> <p><small>(1) Other stroke lengths available upon request. Please contact customer support. (2) Only available with 24 Vdc input voltage. (3) Available for both 24 and 48 Vdc input voltages.</small></p>			

Performance Diagrams

Screw Type and Dynamic Load Capacity

■ ball screw, 2 kN (450 lbs)
 ■ ball screw, 4 kN (899 lbs)
 ■ ball screw, 6 kN (1348 lbs)

Load vs. Speed

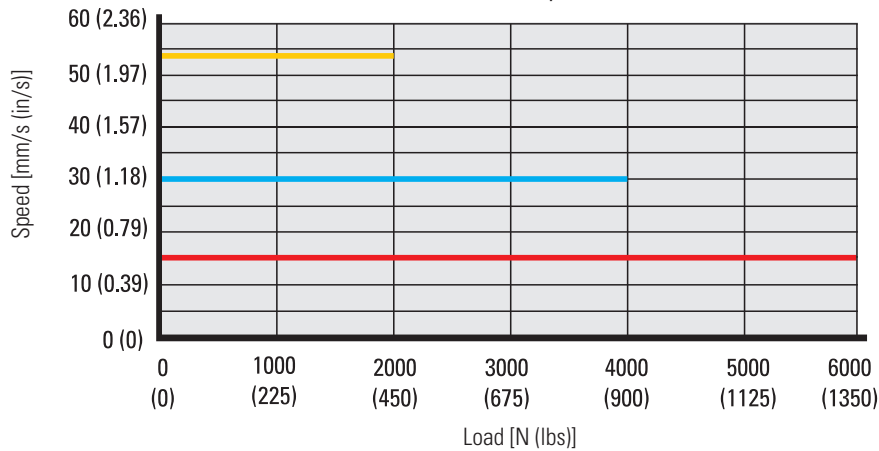

Load vs. Current ⁽¹⁾

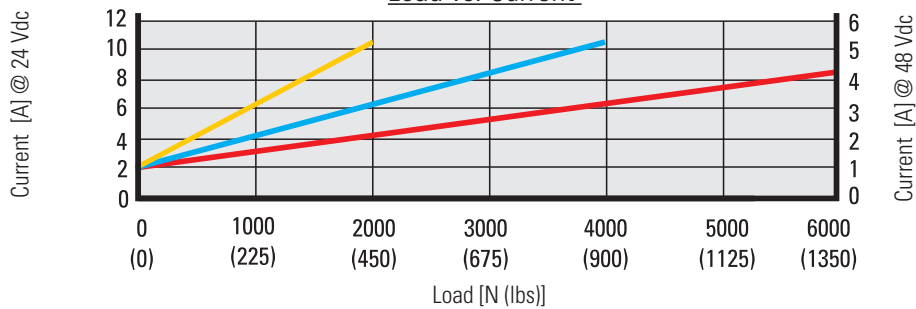

Load vs. Travel Life Distance ⁽²⁾

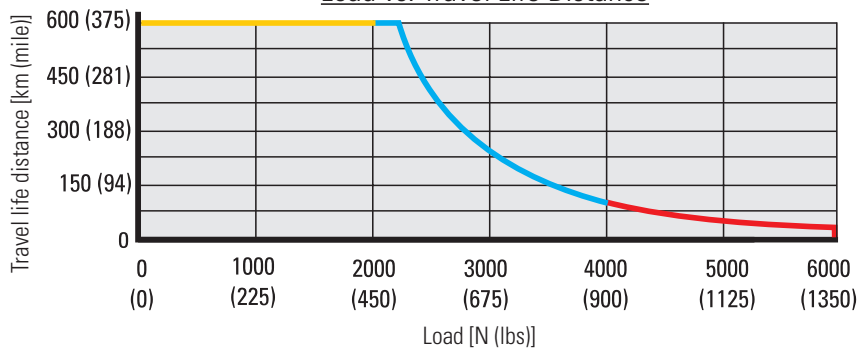

Load vs. Duty Cycle ⁽¹⁾⁽³⁾

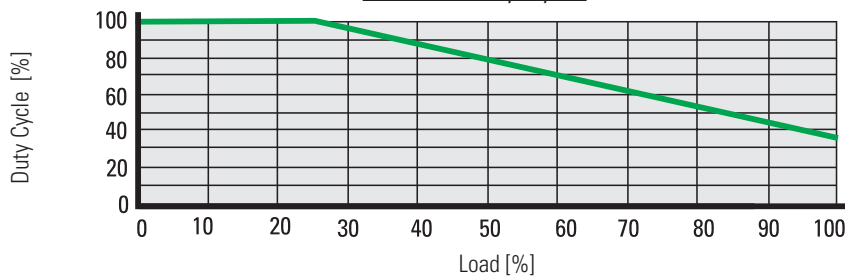

1) Curves were generated at an ambient temperature of 25°C (77°F).

2) The exact travel life also depends on temperature and other environmental factors. Contact customer support for more information.

3) Load in percent of the max permissible load for the screw type and dynamic load capacity in question.



Dimensions

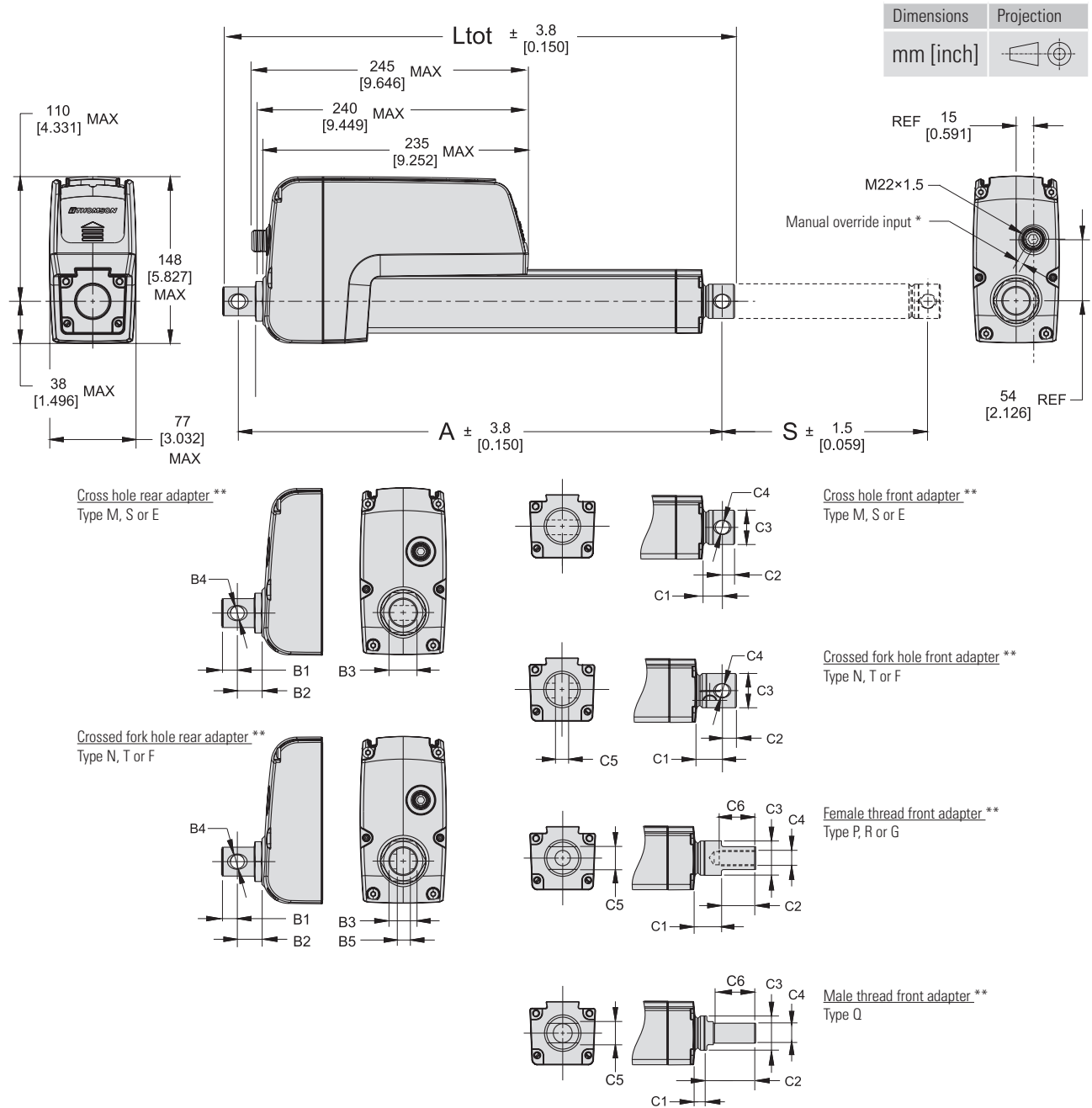

* Manual override input. The input hole is covered with a plastic plug. When removed, a 6 mm female hexagon key can be inserted and used as a crank.

** All adapters shown in the standard orientation.

Dimensions

Ordering Stroke, Retracted Length and Total Length Relationships [mm (in)]

Ordering Stroke (S)	Retracted Length (A)	Total Length (Ltot),
100 - 450 (3.937 - 17.716)	$S + 182 (7.165) + B2 + C1$	$A + B1 + C2$

Rear Adapter Dimensions [mm (in)]

	Adapter Type			
	M, S	E	N, T	F
B1	13.4 (0.53)			
B2	21.6 (0.85)			
B3	25.4 (1.0)			
B4	12.2 E9 (0.48)	12.8 (0.506)	12.2 E9 (0.48)	12.8 (0.506)
B5	-	-	8.2 (0.323)	

Front Adapter Dimensions [mm (in)]

	Adapter Type						
	M, S	E	N, T	F	P, R	G	Q
C1	24.0 (0.945)	27.0 (1.063)		24.9 (0.980)		13.2 (0.519)	
C2	10.9 (0.429)	12.9 (0.508)		30 (1.18)		42 (1.654)	
C3	34.93 (1.375)						
C4	12.2 E9 (0.48)	12.8 (0.506)	12.2 E9 (0.48)	12.8 (0.506)	M12 × 1.75	1/2-20 NF-2B	M16 × 2
C5	-	-	8.2 (0.323)		19 (0.748)		
C6	-	-	-	-	35 (1.38)		



Keypoints for Successful Actuator Control

In order to run and control the actuator successfully, there are several considerations that must be understood. Contact Thomson customer support for advice.

Fuse Protection

Use a slow blow fuse on the supply voltage input wiring to protect the actuator and the wiring. Size it in accordance with local regulations and the current draw for the application in question.

Voltage Drop

Long supply wires may need an increased cross section in order to prevent the supply voltage from dropping to levels below the limits of the actuator. Calculations to determine the necessary cross section should take local regulations, application specifics and the actuator supply voltage limits into account.

Speed Control by Pulse Width Modulation (PWM) or Voltage Adjustment

The actuator speed cannot be changed by PWM control of the supply voltage as this may harm the actuator. Adjusting the input voltage will not change the speed of the actuator but stop it when outside its limits. Actuator speed can only be controlled on units with a CAN bus control using the speed control commands.

Inrush Current

The system must be able to handle the inrush current that occurs at the start of the actuator motor, which can be up to two times the maximum continuous current for the maximum load being used for up to 150 milliseconds.

Regeneration Energy Due to Helping Load

When encountering a helping load, the motor acts as a generator, sending back energy through the system. It is important to ensure that the power supply used can handle the power generated back by the motor.

In cases the power supply cannot handle it, there is a brake resistor output that must be used. For 24V supply voltage resistance should be between 2.3-3.3 Ohm and for 48V supply voltage resistance should be between 4.7-6.8 Ohm. Use a power resistor that can handle at least 100W. Keep in mind that the regenerated energy will produce heat where it is dissipated, whether in the power supply, resistor or elsewhere, that must be handled.

Duty Cycle

While the duty cycle of Electrak LL itself is dependent on the load and the ambient temperature (see graph on page 13, you also must take the duty cycle and temperatures into account when sizing power supplies and other components. Keep in mind that very frequent stops and starts will stress the system more due to the inrush current and/or regeneration energy than steady motion during the same time period.

Control Options

Each control option has capabilities and limitations that need to be understood. Below is a list of the major differences between the options. For more details and wiring, see the information on the following pages and/or in the user manual.

Available Control Options	
LEX	Electrak Monitoring Package + low-level signal motor switching + external end-of-stroke limit switch inputs
LXX	Electrak Monitoring Package + low-level signal motor switching
LXP	Electrak Monitoring Package + low-level signal motor switching + end-of-stroke indication output + absolute position feedback output
CNO	SAE J1939 CAN bus + speed control
COO	CANopen® + speed control

Control Option Functionality

The onboard control options used in Electrak LL can be divided into two groups: those with the Electrak Monitoring Package and those with bus communication.

Low-Level Switching

Both groups of control options are equipped with low-level switching, which allows the customer-supplied switches/relays that are connected to the extend-and-retract inputs to handle only low-level signals and not the voltage and current of the motor.

Electrak Monitoring Package Features

All controls in this group include:

- Current monitoring, shutting down the actuator on overload.
- Temperature and voltage monitoring, protecting the actuator by preventing motion when temperature and/or voltage are outside of normal ranges.
- Temperature compensation, enabling normal operation at low temperatures.
- Software-controlled end-of-stroke limits, protecting the actuator and ensuring smooth stops.
- Dynamic braking, producing quick, repeatable stops with no coasting.

Each control option also has one or more additional feature such as low-level switching or position feedback.

Bus Control Features

Both bus control options - CANopen and SAE J1939 CAN bus - have the same functionality but use slightly different protocols. Each option includes all functions of the Electrak Monitoring Package, capabilities to adjust certain parameters over the bus, plus the following:

- Moving to a position at a speed sent by a host control.
- Sending present position, speed and current to a host control.
- Sending other diagnostic information such as temperature, voltage and error status to a host control.

Control Options Functionality

Feature	Electrak Monitoring Package Controls	Bus Controls
Bus control and communication	no	yes
Low-level switching	yes	yes
Software controlled end-of-stroke protection	yes	yes
Temperature monitoring	yes	yes
Temperature compensation	yes - fixed value	yes - variable parameter
Voltage monitoring	yes	yes
Current monitoring:	yes - fixed value	yes - variable parameter
End-of-stroke inputs	yes - with option LEX	no
Absolute position feedback	yes - with option LXP	yes
Speed control	no	yes

Control Option Functions and Wiring Diagrams

Control Option LEX

Available input voltages	[Vdc]	24
Input voltage tolerance	[Vdc]	16.8 - 32.0
Extend / retract input logical high level	[Vdc]	5 - 32
Extend / retract input high current	[mA]	0.35 - 3.15
Extend / retract input logical low level	[Vdc]	< 0.8

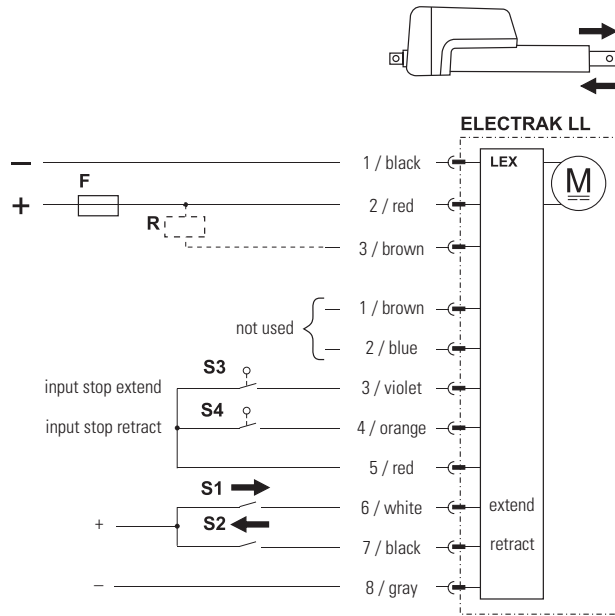

- + / - Positive / negative voltage
- F Fuse
- R Brake resistor
- S1 Switch extend
- S2 Switch retract
- S3 Limit switch stop extend
- S4 Limit switch stop retract

The actuator movement is controlled by connecting a positive voltage to the extend or retract input, and a negative to the common input on lead 8 / gray. There are also external limit switch inputs that stop the actuator from extending or retracting when activated. If you want to detect the position of the extension tube, we recommend using a Thomson reed sensor (part number 840-9132) that mounts directly to the extension tube sensor grooves.

Control Option LXX / LXP

Available input voltages	[Vdc]	24, 48
Input voltage tolerance	[Vdc]	16.8 - 32.0 LL24 (24 Vdc input voltage) LL48 (48 Vdc input voltage)
Extend / retract input logical high level	[Vdc]	9 - 60
Extend / retract input high current	[mA]	0.35 - 2.75
Extend / retract input logical low level	[Vdc]	< 1.2
Position feedback supply voltage	[Vdc]	5 ± 10%
Position feedback output voltage	[Vdc]	0.5 - 4.5
Position feedback linearity	[%]	± 0.25
Position feedback resolution	[mm/V]	ordering stroke length (S) [mm] / 4

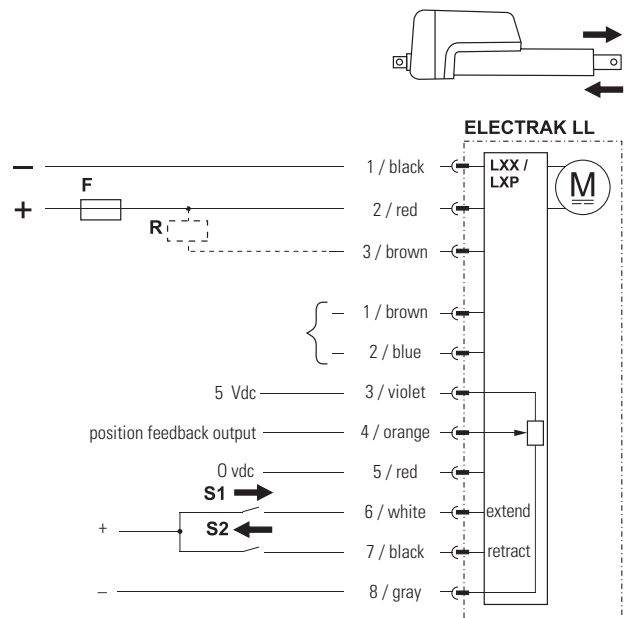

- + / - Positive / negative voltage
- F Fuse
- R Brake resistor
- S1 Switch extend
- S2 Switch retract

On control options LXX and LXP, the actuator movement is controlled by connecting the input voltage positive to the extend or retract input, and the negative to the common input on lead 8 / gray. On the LXP option, there is also an absolute position feedback output.

Control Options Functions and Wiring Diagrams

Control Option Type CNO / COO		
Available input voltages	[Vdc]	24, 48
Input voltage tolerance LL24 (24 Vdc input voltage) LL48 (48 Vdc input voltage)	[Vdc]	16.8 - 32.0 36.0 - 60.0
Extend / retract input logical high level	[Vdc]	9 - 60
Extend / retract input high current	[mA]	0.35 - 2.75
Extend / retract input logical low level	[Vdc]	< 1.2
CAN bus command data includes:		
<ul style="list-style-type: none"> • position • speed • current 		
CAN bus feedback data includes:		
<ul style="list-style-type: none"> • position • speed • current • other diagnostic information 		

Control option CNO includes a SAE J1939 CAN bus control interface, and COO includes a CANopen® control interface that controls and monitors the actuator. Movement commands are sent via CAN messages on the CAN low and CAN high inputs. Address inputs AS1, AS2 and AS3J can be used as a binary coded decimal (BCD) adder to change the default address of the actuator. This option can be used when multiple CAN bus actuators are located on a single bus. The actuator can be manually forced to move by connecting a positive voltage to the extend or retract input, and a negative to the common input. When these manual control inputs are used, CAN bus control messages are ignored, but the unit will still provide CAN bus feedback messages. When the inputs are left floating, CAN bus functionality for control messages is restored. When using the address inputs and/or the manual extend and retract switches, the common input on lead 8 / gray must be connected to negative.

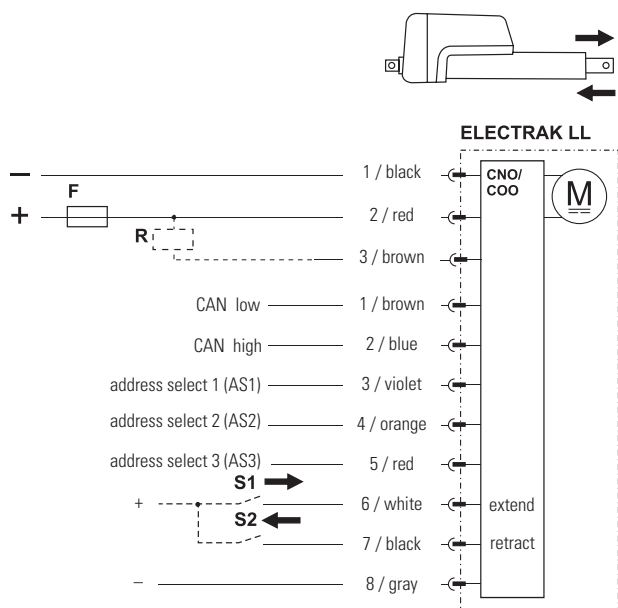

+ / - Positive / negative voltage

R Brake resistor

F Fuse

S1 Switch extend (optional)

S2 Switch retract (optional)

AS1 Address selection switch for binary position 1

AS2 Address selection switch for binary position 2

AS3 Address selection switch for binary position 3

Accessories

Limit Switches for Cover Tube Mounting

Sensor type	solid state	reed switch
Contact type	normally open (N.O.)	
Output type	PNP	contact
Voltage [Vdc/Vac]	10 - 30 / -	5 - 120 / 5 - 120
Max. current [mA]	100	
Hysteresis [mm]	1.5	1.0
Operating temperature [°C]	- 20 to + 70	- 20 to + 70
Lead cross section [mm ²]	3 × 0.14	2 × 0.14
Length (L) [mm]	25.3	30.5
Height (H) [mm]	5.1	5.7
Protection class	IP69K	IP67
LED indicator	yes	
Connection	2 m cable with flying leads	
p/n	840-9131	840-9132

Mounting positions

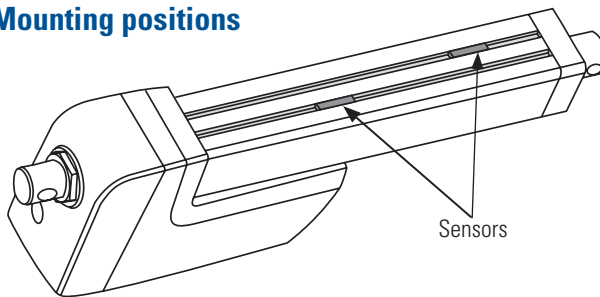

Dimensions [mm]

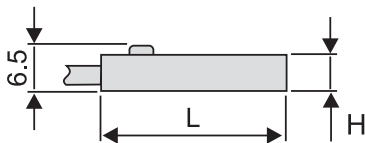

Connection

Solid state

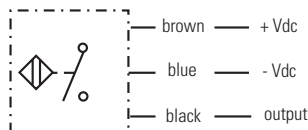

Reed switch

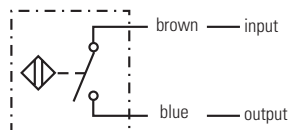

The limit switches are mounted in the cover tube slots and will be switched by a magnet mounted inside of the actuator on the extension tube.

Rod End Front Adapter

Type	metric	inch
Material	Cadmium-plated steel	
Dimensions		
A	12.0 ± 0.1 mm	0.5 in
B	14.3 ± 0.1 mm	0.625 in
C	M12	1/2-20 UNF
p/n	756-9021	756-9007

Dimensions [mm (in)]

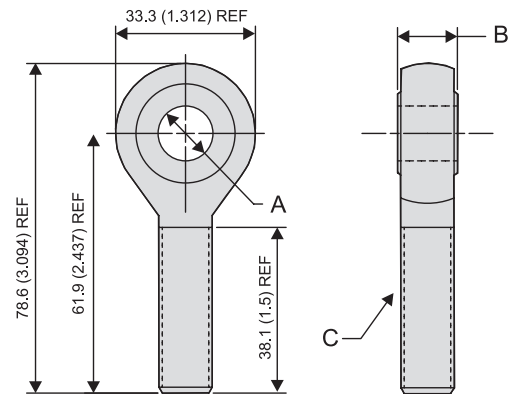

The rod end front adapter comes in a metric or inch version. The metric adapter can be mounted to the front of the extension tube if the actuator is equipped with the metric female thread front adapter option (type P), while the inch adapter requires the inch female thread option (type G).

Frequently Asked Questions

Here are answers to common questions we receive. If you need more information, please contact customer support at www.thomsonlinear.com/cs.

What is the typical life of an actuator?

Life is a function of load and stroke length. Please contact customer support for more information.

What are the most common reasons for premature actuator failure?

Side load due to incorrect mounting, shock loading, exceeding the duty cycle and incorrect wiring are the most prominent causes for premature failure.

What are IP ratings?

International Protection Marking (IP) ratings are commonly referenced standards that classify electrical equipment using standard tests to determine resistance to ingress of solid objects (first digit) and liquids (second digit). See the IP Ratings table below.

Is Electrak® LL suitable for tough environments such as washdown or extreme temperatures?

Yes. Electrak LL actuators are designed for washdown and have passed 500 hours of salt spray tests. They can operate in temperatures ranging from -40 to +85°C (-40 to +185°F).

How is the duty cycle determined?

The duty cycle = on time / on time + off time. For example, if Electrak LL is powered for 15 seconds and then off for 45 seconds, the duty cycle for that minute would be 25%. All models are rated to 35% at full load, and an ambient temperature of 25°C (77°F). If load and/or ambient temperature are lower, then the duty cycle can exceed 35%. At higher temperatures, the duty cycle will be lower.

IP Rating (EN60529)		
Code	First Digit Definition	Second Digit Definition
0	No protection.	No protection.
1	Protected against solid objects over 50 mm.	Protected against vertically falling drops of water.
2	Protected against solid objects over 12.5 mm.	Protected against vertically falling drops of water, if the case is disposed up to 15° from vertical.
3	Protected against solid objects over 2.5 mm.	Protected against vertically falling drops of water, if the case is disposed up to 60° from vertical.
4	Protected against solid objects over 1 mm.	Protected against splash water from any direction.
5	Limited protection against dust ingress (no harmful deposits).	Protected against low-pressure water jets from any direction. Limited ingress permitted.
6	Totally dust protected.	Protected against high-pressure water jets from any direction. Limited ingress permitted.
7	–	Protected against short periods of immersion in water.
8	–	Protected against long, durable periods of immersion in water.
9K	–	Protected against close-range, high-pressure and high-temperature spray downs.



Frequently Asked Questions

Is Electrak LL maintenance free?

Yes. Electrak LL never requires lubrication, maintenance or adjustment for wear.

Is it possible for a load to back-drive the extension tube?

No. The ball screw models incorporate a static load holding brake.

What is the difference between a tension and a compression load?

A tension load tries to stretch the actuator, while a compression load tries to compress it. With bi-directional loads, the end play of the actuator extension tube may need to be taken into consideration when using the actuator for positioning tasks.

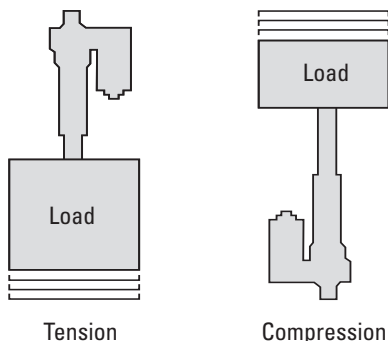

Can Electrak LL be side loaded?

No. A proper design of the application should eliminate any side loads.

What is the range of input voltage an Electrak LL can operate with?

The nominal input voltage is 24 Vdc or 48 Vdc depending on model. A 24 Vdc model will however accept 16.8 – 32 Vdc while the range for 48 Vdc model is 36 – 60 Vdc. Outside of these limits, the Electronic Monitoring Package will prevent the actuator from operating.

Can the speed of an Electrak LL be adjusted by changing the input voltage?

No. When using direct current from a battery or full wave rectifier that are within the acceptable voltage limits, the Electronic Monitoring Package will keep the actuator at the rated speed. Outside of the limits, the actuator will be switched off. If utilizing Pulse Width Modulation (PWM) controls or drives, the actuator PCB can be damaged and is therefore not recommended.

Which power supply should be used with the Electrak LL?

The Electrak LL is equipped with a brushless motor. When running the actuator with a helping load, it will generate energy back into the system/power supply. Thomson recommends using a battery as a power supply. If a transformer or other type of power supply is used, it must be able to handle any energy coming back from the actuator. If the power supply cannot handle the energy, a brake resistor must be connected to the brake resistor output on the control that is capable of handling the energy.

What is the inrush current?

The inrush current is a short current peak that appears at the start of an actuator as the motor tries to get the load moving. Typically, the inrush current will last between 75 – 150 milliseconds and can be up to three times higher (on a low-level switched actuator 1.5 times higher) than the current for the actuator and load. Batteries have no problem delivering the inrush current, but if using an AC powered power supply, it is important to size it to handle the inrush current.

Frequently Asked Questions

What is the maximum travel speed?

The speed of an Electrak LL actuator is constant (and therefore always at its “maximum”) irrespective of the load as long as it is within the rated load range. If the actuator is overloaded, it will stop.

What special mounting considerations does the Electrak LL require?

There is no restraining torque that needs to be considered as Electrak LL is internally restrained. However, the actuator must be mounted so that there are no side loads acting on the extension tube. It is also important that the manual override input is accessible after the actuator is mounted and that connectors and cables are placed so that they are not damaged during operation.

What is a non-contact absolute feedback sensor?

This type of sensor does not have any physical contact with the object it is sensing and, therefore, will have a longer life than other sensors such as a normal potentiometer. The sensor being “absolute” means that it gives out a unique signal for every position so that it can be read directly without the need for counting. Conversely, a potentiometer is absolute as it gives out a resistance unique to each position, but the signal can also be a voltage, current or a unique code. Another advantage with absolute sensors is that they send the correct position when switched on, and, therefore, the system does not require memory to remember the switch off position nor perform homing or calibration routines.

What is the controlled braking feature?

Controlled braking allows the onboard control to slow down and stop movements in a smoother and more controlled fashion than if just cutting the

power to the motor. This results in less stress to the mechanical parts of the actuator and longer life while also producing more accurate stops that are less load dependent.

How does temperature compensation work?

The onboard control measures the temperature and compensates for it to keep the actuator’s performance less temperature sensitive. For example, in cold temperatures, this feature allows the actuator to run at a higher current to keep its maximum load rating without overheating in the colder environment.

What is manual override?

This option is a hexagon-shaped input in the rear of the actuator where an Allen or hex key can be inserted. By rotating the key, the extension tube can be moved back and forth when the actuator is without power. This option can be useful during power outages or if the actuator motor or electronics are broken.

What are halogen-free cables?

Halogen-free cables are more fire-retardant than ordinary cables. They emit less toxic and corrosive fumes, can handle higher temperatures before catching fire, burn slower, and create less smoke. In some applications, such as public transport, laws and regulations may call for the use of halogen-free cables. They are also commonly used in military, air, space and marine applications or wherever enhanced fire protection is required.

Contact us or any of our 2000+ global distribution partners by scanning the code below
or visiting www.thomsonlinear.com/contact



RegalRexnord™

www.regalrexnord.com

www.thomsonlinear.com

Electrak_LL_Actuator_BREN-0033-08 | 20260217KB | MCB-12398-TL-EN-US 02/26
Specifications are subject to change without notice. It is the responsibility of the product user to determine the suitability of this product for a specific application. All trademarks property of their respective owners. ©2026 Thomson Industries, Inc. | 2400 Curtiss Street, Downers Grove, IL 60515 USA

THOMSON®