

# high output torques and compact

With our straight toothed PLN series we present a perfect combination of innovation, efficiency and economy. Whether torque, sturdiness or precision - the attractive series successfully scores no matter what the requirement. The output flange of the PLN is compatible to the helical toothed PSN series, too.

- minimal backlash
- high output torque
- high efficiency
- ground and honed geared parts
- 15 ratios  $i=3, \dots, 100$
- low noise
- high quality (ISO 9001)
- any mounting position
- simple mounting system
- lifetime lubrication
- additional options
- equidirectional rotation
- balanced motor pinion

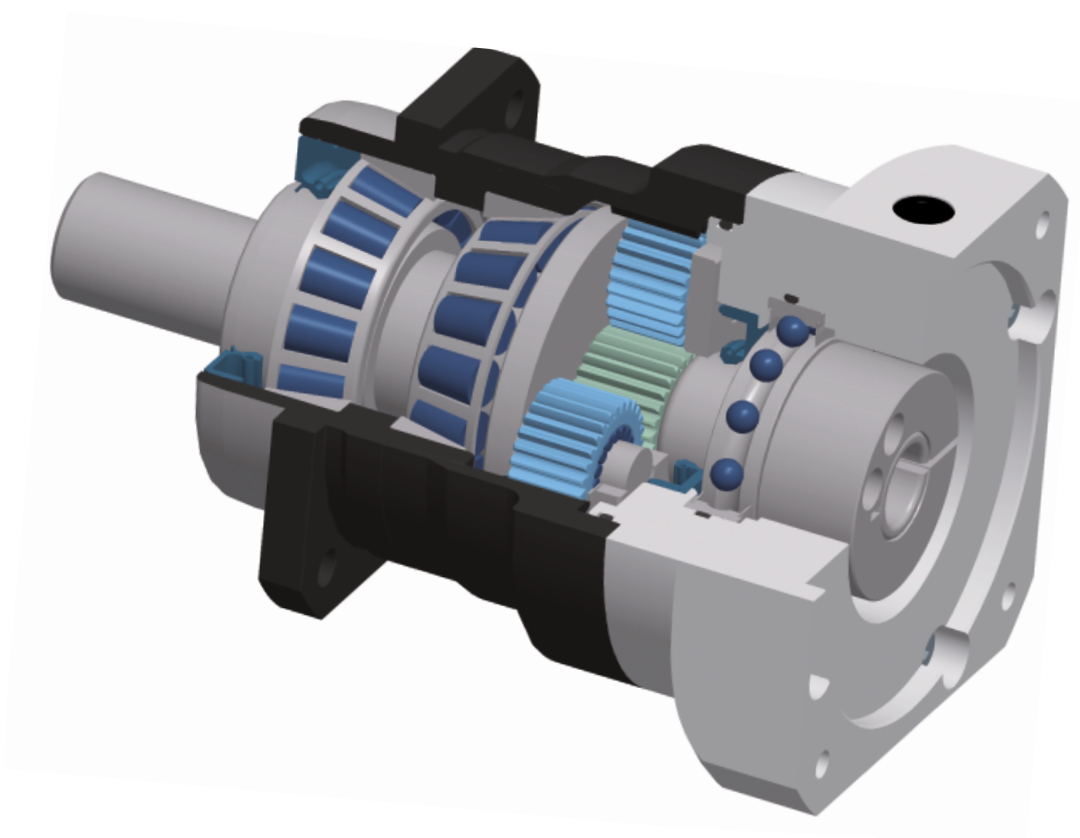

1	Technische Daten	Seite 70
	technical data	page 70
2	Abmessungen	Seite 73
	dimensions	page 73
3	Produktschlüssel	Seite 98
	product code	page 98
4	Ausführung Abtriebsflansch – PLS-kompatibel	Seite 102
	output flange design – PLS-compatible	page 102
5	Ausführung Antrieb – Universalflansch	Seite 106
	input design – universal flange	page 106
6	Technische Grundlagen	Seite 109
	technical background	page 110
7	Auslegung / Berechnung	Seite 4 – <a href="http://www.neugart.com">www.neugart.com</a> und Neugart Calculation Program (NCP)
	dimensioning / calculation	page 4 – <a href="http://www.neugart.com">www.neugart.com</a> and Neugart Calculation Program (NCP)
8	CAD-Zeichnungen, Maßblätter	Seite 5 – <a href="http://www.neugart.com">www.neugart.com</a> und Tec Data Finder (TDF)
	CAD drawings, dimension sheets	page 5 – <a href="http://www.neugart.com">www.neugart.com</a> and Tec Data Finder (TDF)

# PLN Technische Daten technical data

		gearbox characteristics		PLN070	PLN090	PLN115	PLN142	PLN190	Z <sup>(2)</sup>	
	Lebensdauer	service life	t <sub>L</sub>	h	20.000					
	Lebensdauer bei T <sub>2N</sub> x 0,88	service life at T <sub>2N</sub> x 0.88			30.000					
	Wirkungsgrad bei Volllast <sup>(3)</sup>	efficiency at full load <sup>(3)</sup>	η	%	98					1
					95					2
	Betriebstemperatur min.	min. operating temperature	T <sub>min</sub>	°C	-25					
	Betriebstemperatur max.	max. operating temperature	T <sub>max</sub>		90					
	Schutzart	protection class	IP 65							
OP 16	<b>S</b> Standard Schmierung	standard lubrication	Öl / oil – Castrol TRIBOL 800/100							
	<b>F</b> Lebensmitteltaugliche Schmierung	food grade lubrication	Öl / oil – Klübersynth UH1 6-150							
OP 17	<b>L</b> Tieftemperatur Schmierung <sup>(8)</sup>	low temperature lubrication <sup>(8)</sup>	Öl / oil – Klübersynth GH 6-32							
	Einbaulage	installation position	beliebig / any							
	<b>S</b> Standard Verdrehspiel	standard backlash	j <sub>t</sub>	arcmin	< 3	< 3	< 3	< 3	< 3	1
	<b>R</b> Reduziertes Verdrehspiel	reduced backlash			< 5	< 5	< 5	< 5	< 5	< 5
	Verdrehsteifigkeit <sup>(3)</sup>	torsional stiffness <sup>(3)</sup>	c <sub>g</sub>	Nm / arcmin	4,5 - 6	8,6 - 11,5	19,5 - 26,5	45 - 61	123 - 165	1
					4,6 - 6	8,7 - 11,5	20,0 - 26,5	46 - 61	125 - 165	2
	Getriebegegewicht	gearbox weight	m <sub>G</sub>	kg	1,9	3,3	6,9	16	30,5	1
					2,4	4,2	9,5	20,5	45	2
	<b>S</b> Standard Oberfläche Gehäuse	standard housing surface	Citrox – schwarz / black							
	Laufgeräusch <sup>(7)</sup>	running noise <sup>(7)</sup>	Q <sub>g</sub>	dB(A)	68	70	71	75	78	
	Max. Biegemoment bezogen auf den Getriebeantriebsflansch <sup>(1)</sup>	max. bending moment based on the gearbox input flange <sup>(1)</sup>	M <sub>b</sub>	Nm	18	38	80	180	300	
	Motorflanschgenauigkeit	motor flange precision	DIN 42955-R							

Abtriebswellenbelastungen		output shaft loads		PLN070	PLN090	PLN115	PLN142	PLN190	Z <sup>(2)</sup>	
	Radialkraft für 20.000 h <sup>(4)(5)</sup>	radial force for 20,000 h <sup>(4)(5)</sup>	F <sub>r 20.000 h</sub>	N	3200	5500	6000	12500	21000	
	Axialkraft für 20.000 h <sup>(4)(5)</sup>	axial force for 20,000 h <sup>(4)(5)</sup>	F <sub>a 20.000 h</sub>		4400	6400	8000	15000	21000	
	Radialkraft für 30.000 h <sup>(4)(5)</sup>	radial force for 30,000 h <sup>(4)(5)</sup>	F <sub>r 30.000 h</sub>		3200	4800	5400	11400	18000	
	Axialkraft für 30.000 h <sup>(4)(5)</sup>	axial force for 30,000 h <sup>(4)(5)</sup>	F <sub>a 30.000 h</sub>		3900	5700	7000	13200	18500	
	Statische Radialkraft <sup>(5)(6)</sup>	static radial force <sup>(5)(6)</sup>	F <sub>r Stat</sub>		3200	5500	6000	12500	21000	
	Statische Axialkraft <sup>(5)(6)</sup>	static axial force <sup>(5)(6)</sup>	F <sub>a Stat</sub>		4400	6400	8000	15000	21000	

Trägheitsmoment		moment of inertia		PLN070	PLN090	PLN115	PLN142	PLN190	Z <sup>(2)</sup>		
	Massenträgheitsmoment <sup>(3)</sup>	mass moment of inertia <sup>(3)</sup>	J	kgcm <sup>2</sup>	0,216	0,560	1,942	7,008	22,883	1	
					0,365	1,028	3,256	15,270	63,821		
					0,209	0,544	1,933	6,811	22,430		2
					0,249	0,699	2,373	9,813	36,003		

$$(1) \text{ Max. Motorgewicht* in kg} = \frac{0,2 \times M_b}{\text{Motorlänge in m}}$$

\* bei symmetrischer Motorgewichtsverteilung  
\* bei horizontaler und stationärer Einbaulage

(2) Anzahl Getriebestufen

(3) Die übersetzungsabhängigen Werte sind im Tec Data Finder abrufbar – [www.neugart.com](http://www.neugart.com)

(4) Die Angaben beziehen sich auf eine Abtriebswellendrehzahl von n<sub>2</sub>=100 min<sup>-1</sup>

(5) Bezogen auf die Mitte der Abtriebswelle

(6) Abweichende (teilweise höhere) Werte bei Änderungen von T<sub>2N</sub>, F<sub>r</sub>, F<sub>a</sub>, sowie Zyklus und Lagerlebensdauer.

Applikationsspezifische Auslegung mit NCP – [www.neugart.com](http://www.neugart.com)

(7) Schalldruckpegel in 1 m Abstand; gemessen bei einer Antriebsdrehzahl von n<sub>1</sub>=3000min<sup>-1</sup> ohne Last; i=5

(8) Optimale Betriebstemperatur max. 50°C

$$(1) \text{ max. motor weight* in kg} = \frac{0,2 \times M_b}{\text{motor length in m}}$$

\* with symmetrically distributed motor weight  
\* with horizontal and stationary mounting

(2) number of stages

(3) the ratio-dependent values can be retrieved in Tec Data Finder – [www.neugart.com](http://www.neugart.com)

(4) these values are based on an output shaft speed of n<sub>2</sub>=100 rpm

(5) based on center of output shaft

(6) other (sometimes higher) values following changes to T<sub>2N</sub>, F<sub>r</sub>, F<sub>a</sub>, cycle, and service life of bearing.

Application specific configuration with NCP – [www.neugart.com](http://www.neugart.com)

(7) sound pressure level from 1 m, measured on input running at n<sub>1</sub>=3000 rpm no load; i=5

(8) optimal operating temperature max. 50°C

# PLN

Technische Daten technical data

Abtriebsdrehmomente	output torques			PLN070	PLN090	PLN115	PLN142	PLN190	$i^{(1)}$	$Z^{(2)}$
Nenn-Abtriebsdrehmoment <sup>(3)(4)</sup>	nominal output torque <sup>(3)(4)</sup>	$T_{2N}$	Nm	45	100	230	450	1000	3	1
				60	140	300	600	1300	4	
				65	140	260	750	1600	5	
				45	90	180	530	1300	7	
				40	80	150	450	1000	8	
				27	60	125	305	630	10	
				68	110	250	780	1500	12	2
				68	110	250	780	1500	15	
				77	150	300	1000	1800	16	
				77	150	300	1000	1800	20	
				65	140	260	900	1800	25	
				77	150	300	1000	1800	32	
				65	140	260	900	1800	40	
				40	80	150	450	1000	64	
				27	60	125	305	630	100	
				72	160	368	720	1600	3	
96	224	480	960	2080	4					
104	224	416	1200	2560	5					
72	144	288	848	2080	7					
64	128	240	720	1600	8					
43	96	200	488	1008	10					
109	176	400	1248	2400	12	2				
109	176	400	1248	2400	15					
123	240	480	1600	2880	16					
123	240	480	1600	2880	20					
104	224	416	1440	2880	25					
123	240	480	1600	2880	32					
104	224	416	1440	2880	40					
64	128	240	720	1600	64					
43	96	200	488	1008	100					

<sup>(1)</sup> Übersetzungen ( $i=n_1/n_2$ )

<sup>(2)</sup> Anzahl Getriebestufen

<sup>(3)</sup> Bei  $n_{1N}$ 
<sup>(4)</sup> Werte bei Passfeder (Code „A“): für schwelende Belastung

<sup>(5)</sup> Zulässig für 30.000 Umdrehungen der Abtriebswelle; siehe Seite 109

<sup>(1)</sup> ratios ( $i=n_1/n_2$ )

<sup>(2)</sup> number of stages

<sup>(3)</sup> for  $n_{1N}$ 
<sup>(4)</sup> values for feather key (code "A"): for repeated load

<sup>(5)</sup> 30,000 rotations of the output shaft permitted; see page 110

# PLN

Technische Daten technical data

Abtriebsdrehmomente	output torques			PLN070	PLN090	PLN115	PLN142	PLN190	i <sup>(1)</sup>	Z <sup>(2)</sup>				
Not-Aus Drehmoment <sup>(3)</sup>	emergency stop torque <sup>(3)</sup>	T <sub>2Stop</sub>	Nm	90	210	490	975	2000	3	1				
				120	280	650	1300	2700	4					
				130	280	650	1500	3200	5					
				80	175	340	1300	2600	7					
				90	200	380	1000	2600	8					
				90	200	480	750	1350	10					
				135	220	500	1500	3000	12	2				
				135	220	500	1500	3000	15					
				150	300	650	2000	3600	16					
				150	300	650	2000	3600	20					
				150	300	650	1800	3600	25					
				150	300	650	2000	3600	32					
				150	300	650	1800	3600	40					
				80	200	380	1000	2600	64					
								80	200	480	750	1350	100	

Antriebsdrehzahlen	input speeds			PLN070	PLN090	PLN115	PLN142	PLN190	i <sup>(1)</sup>	Z <sup>(2)</sup>
Mittlere thermische Antriebsdrehzahl bei T <sub>2N</sub> und S1 <sup>(4)(5)</sup>	average thermal input speed at T <sub>2N</sub> and S1 <sup>(4)(5)</sup>	n <sub>1N</sub>	min <sup>-1</sup>	2050 <sup>(6)</sup>	1950 <sup>(6)</sup>	1500 <sup>(6)</sup>	850 <sup>(6)</sup>	700 <sup>(6)</sup>	3	1
				2300 <sup>(6)</sup>	2100 <sup>(6)</sup>	1600 <sup>(6)</sup>	950 <sup>(6)</sup>	750 <sup>(6)</sup>	4	
				2650 <sup>(6)</sup>	2500 <sup>(6)</sup>	2000 <sup>(6)</sup>	1050 <sup>(6)</sup>	850 <sup>(6)</sup>	5	
				3450 <sup>(6)</sup>	3550 <sup>(6)</sup>	2800 <sup>(6)</sup>	1550 <sup>(6)</sup>	1200 <sup>(6)</sup>	7	
				3800 <sup>(6)</sup>	3950 <sup>(6)</sup>	3200 <sup>(6)</sup>	1800 <sup>(6)</sup>	1450 <sup>(6)</sup>	8	
				4400 <sup>(6)</sup>	4000	3500 <sup>(6)</sup>	2250 <sup>(6)</sup>	1900 <sup>(6)</sup>	10	
				3550 <sup>(6)</sup>	3400 <sup>(6)</sup>	2450 <sup>(6)</sup>	1300 <sup>(6)</sup>	1000 <sup>(6)</sup>	12	2
				4000 <sup>(6)</sup>	4000 <sup>(6)</sup>	3000 <sup>(6)</sup>	1600 <sup>(6)</sup>	1250 <sup>(6)</sup>	15	
				3800 <sup>(6)</sup>	3550 <sup>(6)</sup>	2550 <sup>(6)</sup>	1350 <sup>(6)</sup>	1050 <sup>(6)</sup>	16	
				4300 <sup>(6)</sup>	4000 <sup>(6)</sup>	3050 <sup>(6)</sup>	1600 <sup>(6)</sup>	1300 <sup>(6)</sup>	20	
				4500 <sup>(6)</sup>	4000 <sup>(6)</sup>	3400 <sup>(6)</sup>	1850 <sup>(6)</sup>	1400 <sup>(6)</sup>	25	
				4500	4000	3500 <sup>(6)</sup>	2300 <sup>(6)</sup>	1900 <sup>(6)</sup>	32	
				4500	4000	3500	2550 <sup>(6)</sup>	2100 <sup>(6)</sup>	40	
				4500	4000	3500	3000 <sup>(6)</sup>	2500 <sup>(6)</sup>	64	
				4500	4000	3500	3000	2500	100	
				Max. mechanische Antriebsdrehzahl <sup>(4)</sup>	max. mechanical input speed <sup>(4)</sup>	n <sub>1Limit</sub>	min <sup>-1</sup>	14000	10000	8500

<sup>(1)</sup> Übersetzungen (i=n<sub>1</sub>/n<sub>2</sub>)

<sup>(2)</sup> Anzahl Getriebestufen

<sup>(3)</sup> 1000-mal zulässig

<sup>(4)</sup> Applikationsspezifische Auslegung der Drehzahlen mit NCP – [www.neugart.com](http://www.neugart.com)

<sup>(5)</sup> Definition siehe Seite 109

<sup>(6)</sup> Mittlere thermische Antriebsdrehzahl bei 50% T<sub>2N</sub> und S1

<sup>(1)</sup> ratios (i=n<sub>1</sub>/n<sub>2</sub>)

<sup>(2)</sup> number of stages

<sup>(3)</sup> permitted 1000 times

<sup>(4)</sup> application-specific speed configurations with NCP – [www.neugart.com](http://www.neugart.com)

<sup>(5)</sup> see page 110 for the definition

<sup>(6)</sup> average thermal input speed at 50% T<sub>2N</sub> and S1

# PLN Abmessungen dimensions

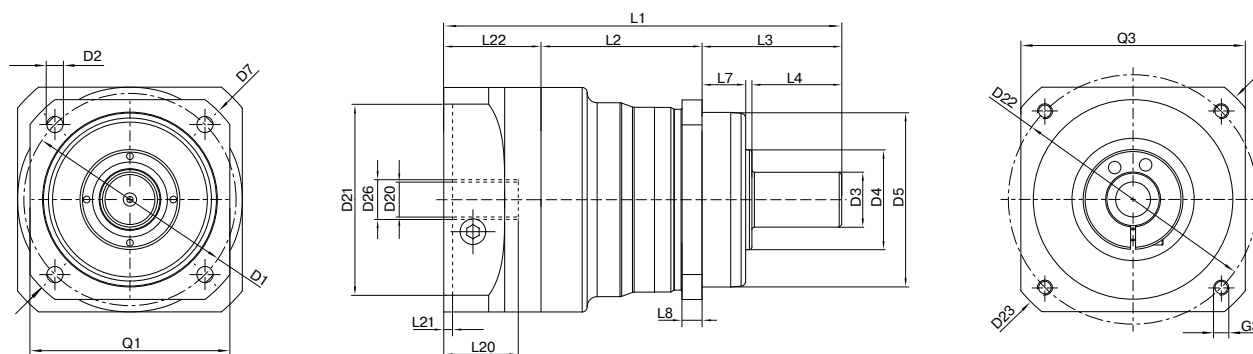

Darstellung entspricht einem PLN090 / 1-stufig / glatte Abtriebswelle / 19 mm Spannsystem / Motoranpassung – 2-teilig – runder Universalfansch / B5 Flanschttyp Motor  
 drawing corresponds to a PLN090 / 1-stage / smooth output shaft / 19 mm clamping system / motor adaptation – 2-part – round universal flange / B5 flange type motor  
 Alle weiteren Varianten sind im Tec Data Finder abrufbar unter [www.neugart.com](http://www.neugart.com) – All other variants can be retrieved in Tec Data Finder at [www.neugart.com](http://www.neugart.com)

Geometrie*	geometry*			PLN070	PLN090	PLN115	PLN142	PLN190	Z <sup>(1)</sup>
Lochkreisdurchmesser Abtrieb	pitch circle diameter output	D1		68 - 75	85	120	165	215	
Montagebohrung Abtrieb	mounting bore output	D2	4x	5,5	6,5	9	11	13,5	
Wellendurchmesser Abtrieb	shaft diameter output	D3	k6	16	22	32	40	55	
Wellenansatz Abtrieb	shaft collar output	D4	-3	35	40	45	70	80	
Zentrierbund Ø Abtrieb	centering Ø output	D5	g7	60	70	90	130	160	
Diagonalmass Abtrieb	diagonal dimension output	D7		92	100	140	185	240	
Flanschquerschnitt Abtrieb	flange cross section output	Q1	□	70	80	110	142	190	
Gehäuselänge	housing length	L2		59	64,5	61,5	91,5	116	1
				88	96,5	101,5	150,5	188	2
Wellenlänge Abtrieb	shaft length output	L3		48	56	88	110	112	
Zentrierbundtiefe Abtrieb	centering depth output	L7		19	17,5	28	28	28	
Flanschdicke Abtrieb	flange thickness output	L8		7	8	10	12	15	
Ø Spannsystem am Antrieb	clamping system Ø input	D26		Weitere Informationen auf Seite 99 more information on page 99					
Gesamtlänge	total length	L1		Die Maße variieren je nach Motor-/Getriebeflansch. Die motorspezifischen Antriebsflansch-Geometrien können im Tec Data Finder für jeden Motor gezielt abgerufen werden — <a href="http://www.neugart.com">www.neugart.com</a>  The dimensions vary with the motor/gearbox flange. The input flange geometries can be retrieved for each specific motor in Tec Data Finder at <a href="http://www.neugart.com">www.neugart.com</a>					
Durchmesser Motorwelle j6/k6	motor shaft diameter j6/k6	D20							
Max. zul. Motorwellenlänge	max. permis. motor shaft length	L20							
Min. zul. Motorwellenlänge	min. permis. motor shaft length								
Zentrierbund Ø Antrieb	centering Ø input	D21							
Zentrierbundtiefe Antrieb	centering depth input	L21							
Lochkreisdurchmesser Antrieb	pitch circle diameter input	D22							
Motorflanschlänge	motor flange length	L22							
Diagonalmass Antrieb	diagonal dimension input	D23							
Anschraubgewinde x Tiefe	mounting thread x depth	G3	4x						
Flanschquerschnitt Antrieb	flange cross section input	Q3	□						
Abtriebswelle mit Passfeder (DIN 6885 T1)	output shaft with feather key (DIN 6885 T1)			A 5 x 5 x 25	A 6 x 6 x 28	A 10 x 8 x 50	A 12 x 8 x 65	A 16 x 10 x 70	
Passfederbreite (DIN 6885 T1)	feather key width (DIN 6885 T1)	B1		5	6	10	12	16	A Code OP7
Wellenhöhe inklusive Passfeder (DIN 6885 T1)	shaft height including feather key (DIN 6885 T1)	H1		18	24,5	35	43	59	
Wellenlänge bis Bund	shaft length from shoulder	L4		28	36	58	80	82	
Passfederlänge	feather key length	L5		25	28	50	65	70	
Abstand von Wellenende	distance from shaft end	L6		2	4	4	8	6	
Zentrierbohrung (DIN 332, Form DR)	center hole (DIN 332, type DR)	Z		M5 x 12,5	M8 x 19	M12 x 28	M16 x 35	M20 x 42	
Glatte Abtriebswelle	smooth output shaft								B Code OP6
Wellenlänge bis Bund	shaft length from shoulder	L4		28	36	58	80	82	
Verzähnte Abtriebswelle (DIN 5480)	toothed output shaft (DIN 5480)			W 16 x 0,8 x 18 x 6m	W 22 x 1,25 x 16 x 6m	W 32 x 1,25 x 24 x 6m	W 40 x 2,0 x 18 x 6m	W 55 x 2,0 x 26 x 6m	C Code OP26
Verzahnungsbreite	toothing width	L <sub>v</sub>		15	15	15	20	22	
Zentrierbohrung (DIN 332, Form DR)	center hole (DIN 332, type DR)	Z		M5x12,5	M8x19	M12x28	M16x36	M20x42	
Wellenlänge bis Bund	shaft length from shoulder	L4		26	26	26	40	41,5	

(1) Anzahl Getriebestufen

(1) number of stages

\* Maße in mm dimensions in mm