



**PWB encoders GmbH
Am Goldberg 2
D-99817 Eisenach
Germany
Phone: +49 3691 72580-0
Fax: +49 3691 72580-29**

**info@pwb-encoders.com
www.pwb-encoders.com**

Description

The AE30 is a reliable low cost optical hollow shaft encoder that can be fixed quickly and easily on different sizes of motor shafts.

The AE 30 encoder with RS 422 high speed differential line driver (Texas Instruments AM26C31) provides up to three differential output signals A / \bar{A} ; B / \bar{B} (in quadrature 90 degrees phase shifted) and one optional index channel I / \bar{I} (one pulse per revolution).

The resolution of the encoder is determined by the number of counts per revolution (CPR). Power supply and signals are provided by an 8 pin Molex connector.

Dimensions

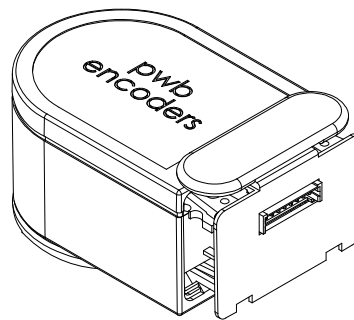
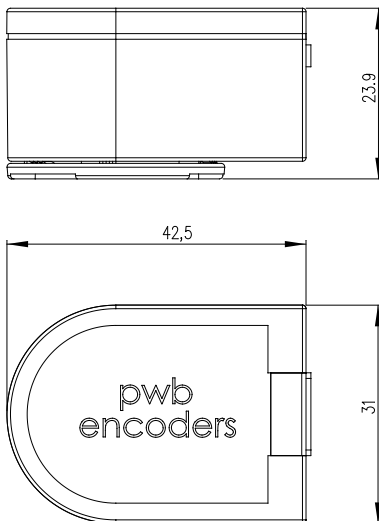

Encoder Resolution (CPR)
100
200
256
360
400
500
512
1000
1024
2000
2048
2500
4000
4096
5000

Main characteristics

- Hollow shaft encoder
- High performance in compact size
- Robust plastic housing
- Quick and easy assembly
- Resolutions up to 5000 counts per revolution (CPR)
- Two channel differential line driver output ($A , \bar{A} / B , \bar{B}$)
- Three channel differential line driver output ($A , \bar{A} / B , \bar{B} / I , \bar{I}$)
- Max. 20 mA output drive capability
- Operating temperature range -40 °C to +100 °C
- Several shaft diameter options
- No signal adjustment required
- Compliant EU-directive 2011/65/EU (RoHS)

Motor shaft Ø Diameter (mm)
A = 1.800
B = 2.000
C = 2.500
D = 3.000
E = 3.175 (1/8")
F = 3.969 (5/32")
G = 4.000
H = 4.763 (3/16")
I = 5.000
J = 6.000
K = 6.350 (1/4")
L = 8.000

Applications

- For high volume applications like factory and office automation
- Consumer electronics, white goods, automatic handlers, doors and windows controls

Absolute maximum ratings

Parameter	Symbol	Min.	Typ.	Max.	Unit	Notes
Storage temperature ^{M1}	T _S	-40		100	°C	
Storage temperature ^{M2}	T _S	-40		85	°C	
Supply voltage	V _{cc}	-0.5		to 7.0	V _{DC}	
Output voltage	V _{out}	-0.5		to V _{cc}	V	
Output current	I _{out}			± 20	mA	per Channel

Recommended operating conditions

Encoding characteristics over recommended operating range and recommended mounting tolerances unless otherwise specified.

Parameter	Symbol	Min.	Typ.	Max.	Unit	Notes
Operating temperature ^{M1}	T _A	-40		100	°C	
Operating temperature ^{M2}	T _A	-40		85	°C	
Supply voltage	V _{cc}	4.5	5.0	5.5	V _{DC}	Ripple < 100 mV _{p-p}
Supply current	I _{cc}			110	mA	No load
Load capacitance	C _L			100	pF	
Count frequency	f			100	kHz	up to 1024 CPR
				500		2000 - 2500 CPR
				1000		4000 - 5000 CPR

Electrical characteristics

Parameter	Symbol	Min.	Typ.	Max.	Unit	Notes
High Level Output Voltage	V _{oH}	2.4			V	I _{oH} : - 20mA
High Level Output Current	I _{oH}			-20	mA	
Low Level Output Voltage	V _{oL}			0.4	V	I _{oL} : 20mA
Low Level Output Current	I _{oL}			20	mA	
Rise Time	t _r		120		ns	R _L : 100 Ω
Fall Time	t _f		50		ns	C _L : 15 pF

Note: Ch. A+ / A- & Ch. B+ / B- quadrature output + Ch. I+ / I- index output

ESD Warning: Normal handling precautions should be taken to avoid static discharge damage to the sensor.

Encoder characteristic

Encoding characteristics over recommended operating range and recommended mounting tolerances unless otherwise specified.

	Parameter	Symbol	Min.	Typ.	Max.	Unit
4 channels + 2 index ^{M1}	Pulse width error	ΔP		± 7	± 40	$^{\circ}e$
	State width error	ΔS		± 5	± 40	$^{\circ}e$
	Phase error	$\Delta \phi$		± 2	± 25	$^{\circ}e$
	Index pulse width	P_0	60	90	120	$^{\circ}e$
4 channels ^{M2}	Pulse width error	ΔP		± 7	± 45	$^{\circ}e$
	State width error	ΔS		± 5	± 45	$^{\circ}e$
	Phase error	$\Delta \phi$		± 2	± 20	$^{\circ}e$

Note: M1/M2: see ordering codes

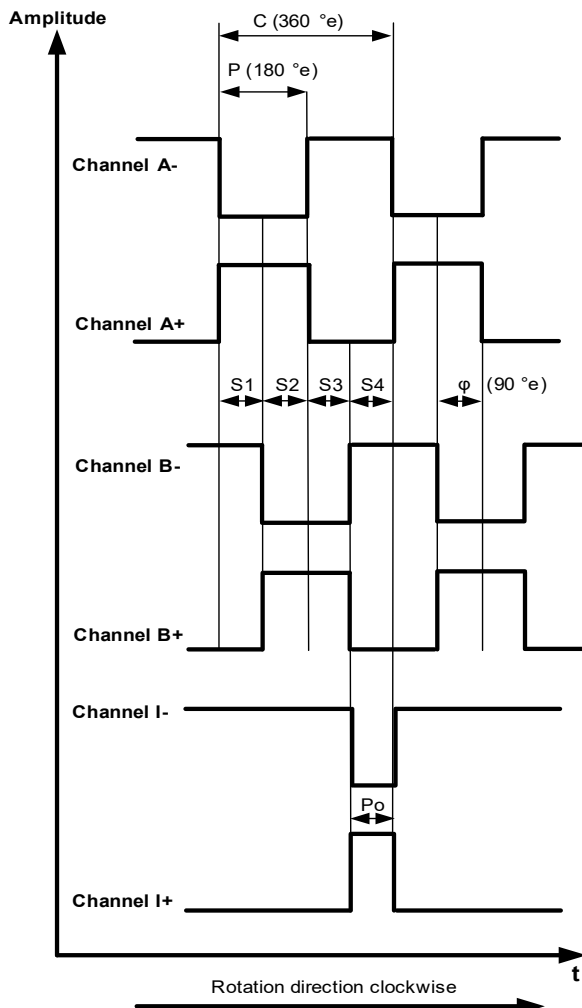

Definitions

Count (N): The number of bar and window pairs or increments per revolution (CPR) of the code wheel.

One Cycle C: One period of the signal, related to 1 bar and 1 window. It is measured in electrical degrees, one cycle is 360 electrical degrees ($^{\circ}e$).

Cycle Error (ΔC): The deviation in electrical degrees of the pulse width from its ideal value. It is an indication of cycle uniformity.

Pulse Width (P): The number of electrical degrees when an output is "HIGH" during one cycle, nominally 180 $^{\circ}e$ or half a cycle.

Pulse Width Error (ΔP): The deviation in electrical degrees of the pulse width from its ideal value of 180 $^{\circ}e$.

State Width (S): The number of electrical degrees between a transition in the output of channel A and the neighbouring transition in the output of channel B. There are 4 states per cycle, each nominally 90 $^{\circ}e$ (S1 – S4).

State Width Error (ΔS): The deviation in electrical degrees of each state width from its ideal value of 90 $^{\circ}e$.

Phase (ϕ): The number of electrical degrees between the centre of the high state on channel A and the centre of the high state on channel B. This value is nominally 90 $^{\circ}e$ (the signals A and B can be used for quadrature).

Phase Error ($\Delta \phi$): The deviation in electrical degrees of the phase from its ideal value of 90 $^{\circ}e$.

Index pulse width (P_0): The number of electrical degrees when the index is high during one full shaft revolution.

Connector output

Encoder header connector: Wennmacher CX-W125R-8-DIP ^{M1}
Molex 53048-0810 ^{M2}

Housing connector: Wennmacher CX-H-125-8 with CX-T125F terminals ^{M1}
Molex 51021-0800 with 50079-8000 terminals ^{M2}

Pin-out description

Pin	Output pin	Description	Wire colors (UL 10002) ^{M1}	Wire colors (UL 1061) ^{M2}
1	Vcc	Power supply	red	red
2	I +	Index I+	green	green
3	I -	Index I -	blue	blue
4	B +	Channel B+	purple	purple
5	B -	Channel B -	brown	brown
6	A +	Channel A+	yellow	yellow
7	A -	Channel A -	white	orange
8	GND	Ground	black	black

Note: M1/M2: see ordering codes & cable accessories

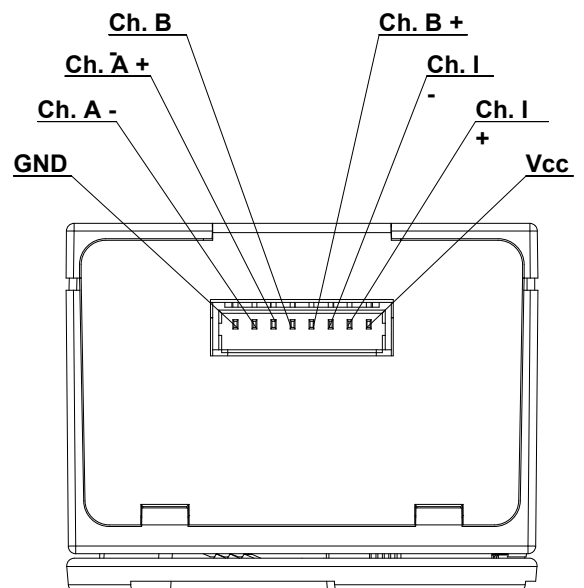
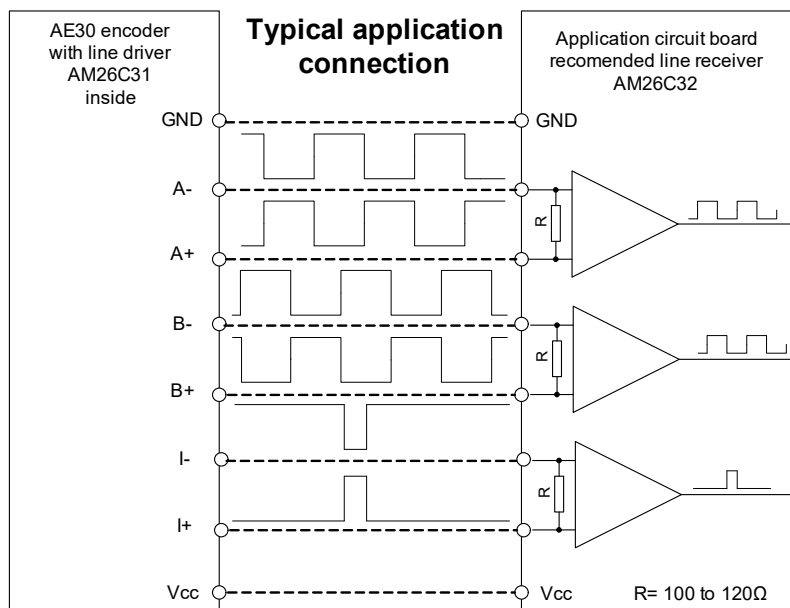

Mechanical characteristics and drawings

Parameter	Value	Tolerance	Unit
Dimensions	42.5 x 31.0 x 23.9 (refer to Page 2)		mm
Weight	17		g
Shaft diameters \varnothing	1.8 / 2.0 / 2.3 / 2.5 / 3.0 / 3.175 / 3.969 / 4.0 / 4.763 / 5.0 / 6.0 / 6.35 / 8.0 (see Fig.2 below)	± 0.01	mm
Motor shaft length protrusion L	9.5 (see Fig.2 below)	+ 1.5	mm
Max. motor mounting boss diameter D	13.0 (see Fig.2 below)		mm
Max. motor mounting boss height H	2.0 (see Fig.2 below)		mm
Max. motor axial shaft play		± 0.25	mm
Max. motor shaft eccentricity + radial play	0.05 (eccentricity decreases signal performances)		mm
Screws for fixing	2 X M3 (DIN 965) 3 X M2 (DIN 7985)		
Tightening torque of the screws	15	-5	Ncm
Flange print	Refer to Fig.3 below		
Protection grade	IP50 (according to DIN 40500)*		
Plastic material	PBT, 17% glass fibre reinforced UL 94 V-0		

Note: * When the encoder is properly assembled

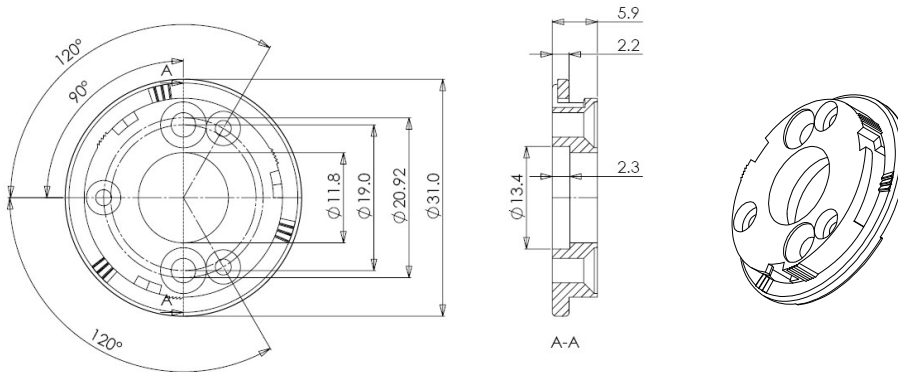

Fig. 1 Flange dimension

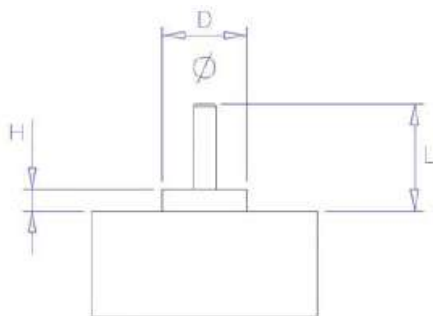

Fig. 2 Motor shaft tip

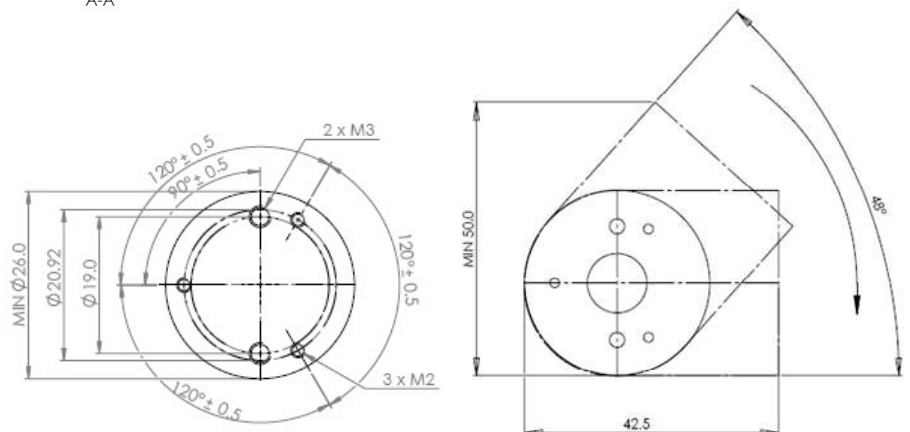

Fig. 3 Flange print

AE30 MOUNTING INSTRUCTION

1



Align the base plate to the motor shaft by using the centering gauge

2

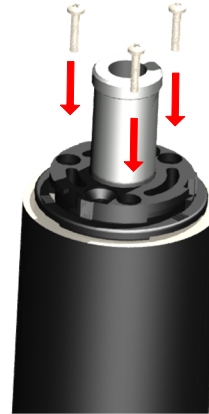

Afterwards fix the base plate to the motor flange using two screws (M3) or three screws (M2)

3

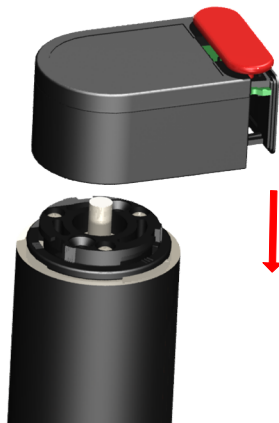

Align the hole of the hub to the motor shaft and push the encoder until it will touch the flange

4

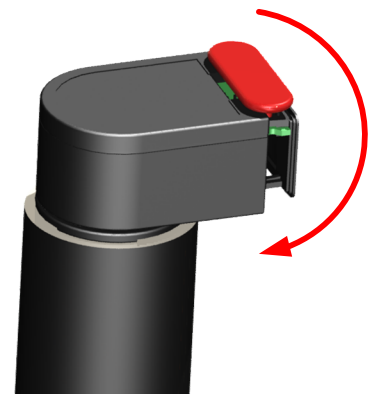

When the encoder fits totally onto the flange, start to rotate the encoder clockwise.....

5

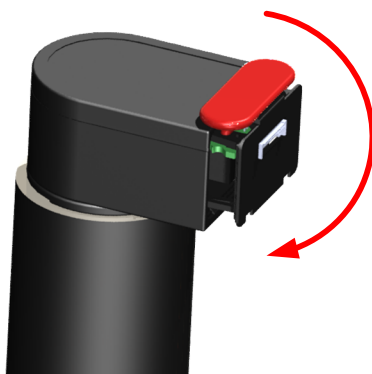

..... until a stop point is reached

6

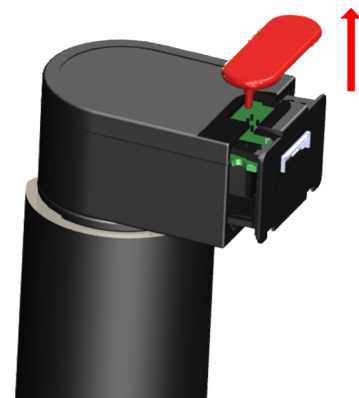

After assembling the encoder on the flange, remove the stopper.

AE30 MOUNTING INSTRUCTION

7

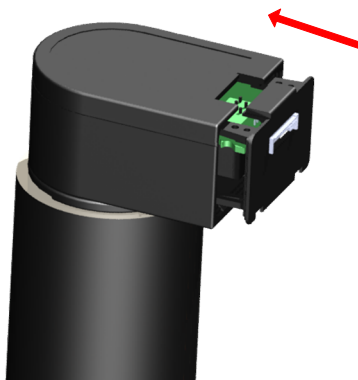

Push the wall into the housing into its final position.

8



Now the encoder is ready for use.

WARNING



Do not rotate the encoder after assembly or when it is in operation.



Do not pull out the wall after assembly or when it is in operation.

ATTENTION!

The encoder is designed to be assembled only one time, otherwise the guarantee will be voided.

Note: see IMPORTANT NOTICE (page 12)

Available accessories

Standard cable

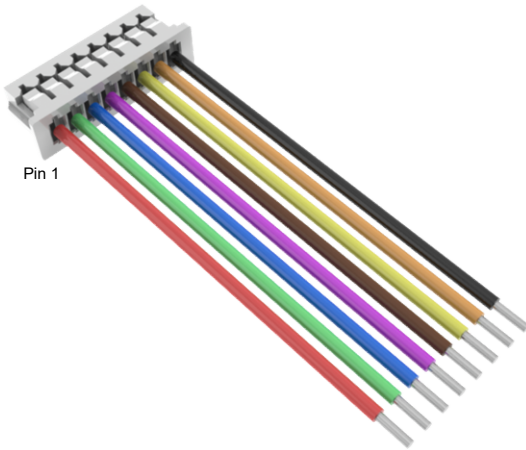

Cable 300 mm length UL 10002 / AWG28 ^{M1}
with female housing connector:
Wennmacher CX-H-125-8 with CX-T125F terminals

Cable 300 mm length UL1061 / AWG26 ^{M2}
with female housing connector:
Molex 51021-0800 with 50079-8000 terminals

Note: M1/M2: see ordering codes

Adapter cable

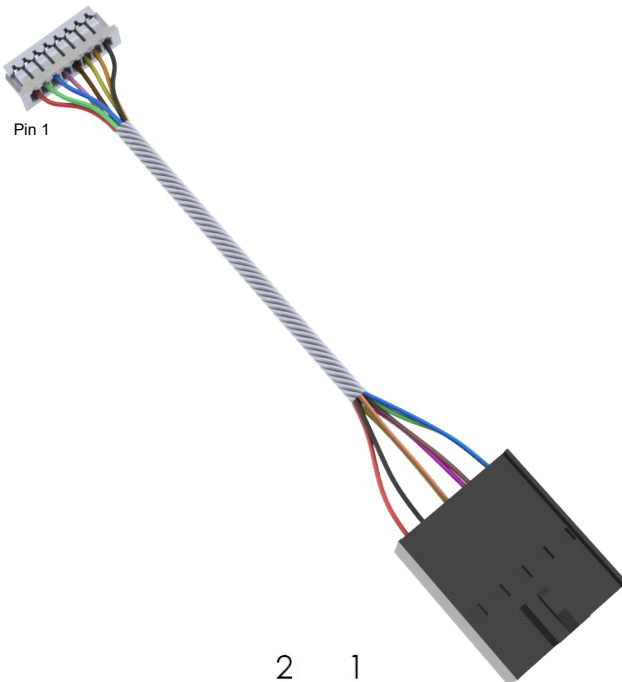

Twisted adapter cable 500 mm length UL10002 / AWG28 ^{M1}
with female housing connector:
8-pin Wennmacher connector
(Wennmacher CX-H-125-8 Housing with CX-T125F terminals)
to a 10-pin Molex connector
(Molex 90142-0010 Housing with 90119-2121 terminals)

Twisted adapter cable 500 mm length UL1061 / AWG26 ^{M2}
with female housing connector:
8-pin Molex connector
(Molex 51021-0800 with 50079-8000 terminals)
to a 10-pin Molex connector
(Molex 90142-0010 Housing with 90119-2121 terminals)

Note: M1/M2: see ordering codes

Pin-out description 10 pin connector side

Pin	Output pin	Description	Colors
1	N.C.	Not connected	
2	Vcc	Power supply	red
3	GND	Ground	black
4	N.C.	Not connected	
5	A -	Channel A-	orange / white *
6	A +	Channel A+	yellow
7	B -	Channel B-	brown
8	B +	Channel B+	purple
9	I -	Index I-	blue
10	I +	Index I+	green

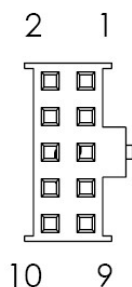

Connector front view

Note: only for M1 version

Available accessories

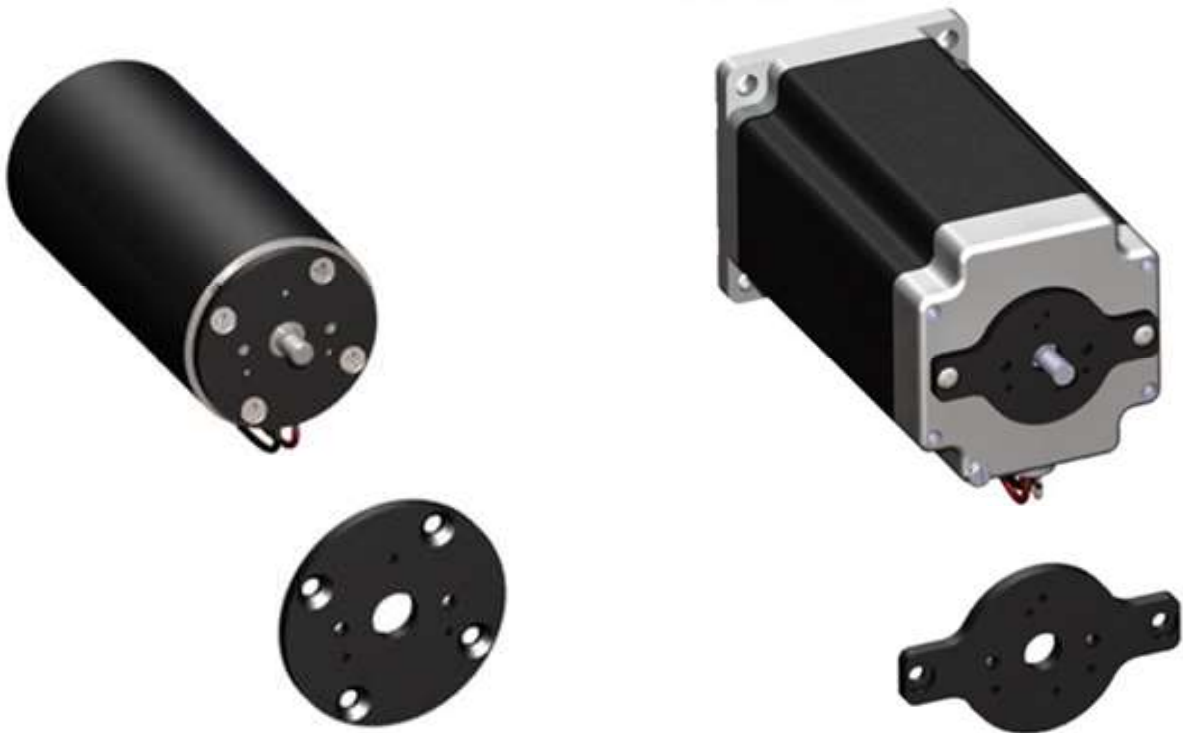

Customized adapter plate



Centering gauge for different motor shafts



Screws 3 pcs DIN 7985 M2 X 8



Screws 2 pcs DIN 965 M3 X 8

Ordering codes

AE30 - X - XXXX - XX - XX - X - XX - X

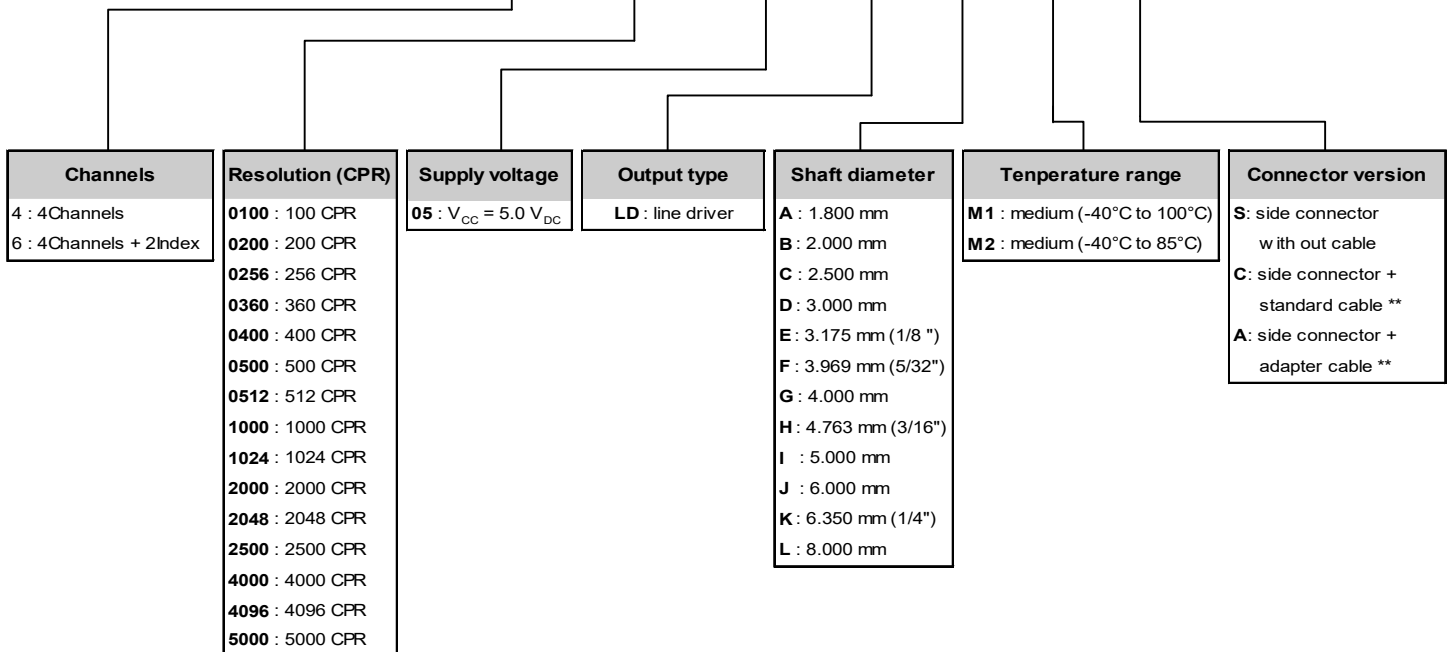

Note:
** see page 9

Available accessories (no parts of standard delivery):

- standard cable 300 mm length
- adapter cable 500 mm length
- adapter plates for different motors
- centering gauge for different motor shafts (highly recommended for correct assembly)
- fastening screws 3pcs DIN 7985 M2 X 8
- fastening screws 2pcs DIN 965 M3 X 8

PWB encoders GmbH RESTRICTED

THIS DOCUMENT AND ANY ASSOCIATED DATA CONTAIN RESTRICTED INFORMATION THAT IS PROPERTY OF PWB encoders GmbH AND MAY NOT BE DISCLOSED OR DUPLICATED FOR OTHERS EXCEPT AS AUTHORIZED BY PWB

INFORMATION CONTAINED IN THIS PUBLICATION MAY BE SUPERSEDED BY UPDATES. IT IS YOUR RESPONSIBILITY TO ENSURE THAT YOUR APPLICATION MEETS WITH YOUR SPECIFICATIONS.

Patents: US: 7394219 DE:102004036903.8 EP: 1621854 JP: 2006038867

IMPORTANT NOTICE

The encoder is so designed that it may be assembled only one time, otherwise the guarantee will be voided.

The guarantee will be voided by misuse, accident, modification, unsuitable physical or operating environment, operation in other than the specified operating environment, or failure caused by a product for which **PWB encoders GmbH** is not responsible.

PWB encoders GmbH reserves the right to make corrections, modifications, enhancements, improvements, and other changes to its products and services also datasheets at any time.