

Anschluß / Connection

HL1x - Nema 17

» Connector: JST PHR-6 » Terminal: JST SPH-002T-PO5L » Leads: AWG26 UL1569

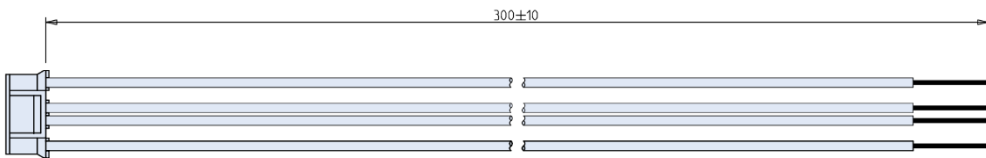

Lead wires		
pin #	Colour	Function
1	White ○	phase A+
3	Yellow ●	phase A-
4	Red ●	phase B+
6	Blue ●	phase B-

HL6x – Nema 24

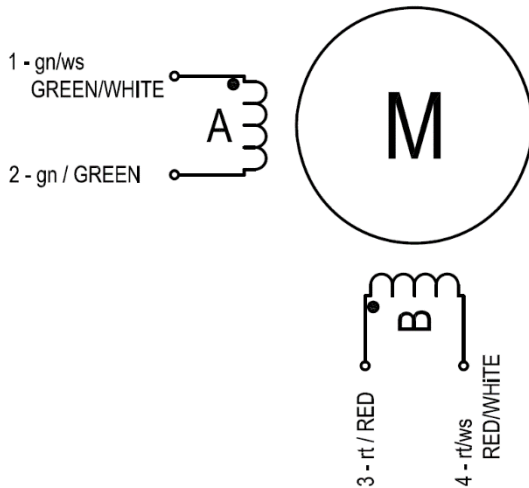

HL3x – Nema 34

