

Abmessungen / Dimensions

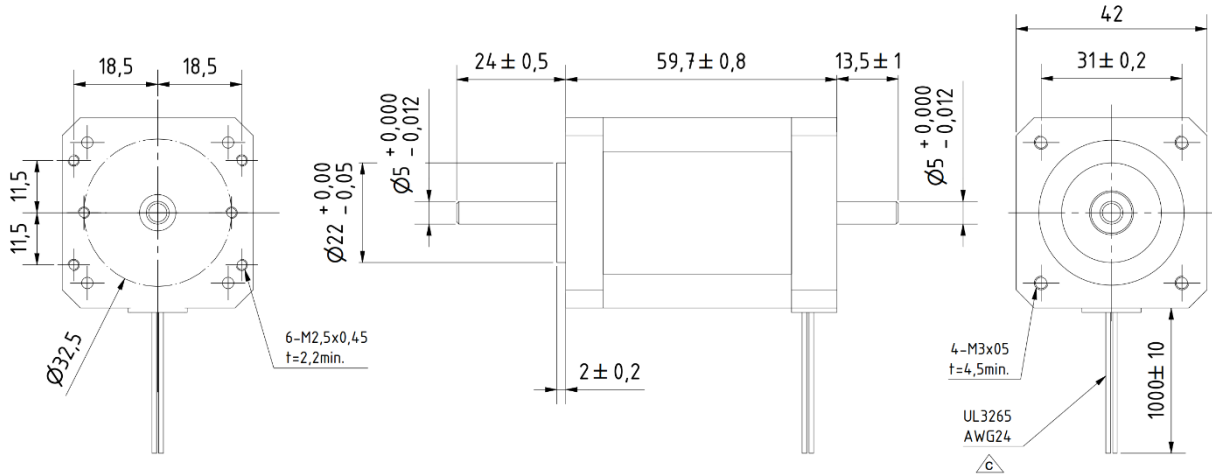

Anmerkungen / Notes : Alle Abmessungen in mm / All dimensions in mm

Motordaten / Motor Data

Haltemoment bipolar, parallel zwei Phasen bestromt / <i>Holding Torque</i>	M_H	Nm	0,91
Nennstrom pro Phase / <i>Rated Phase Current</i>	I	A	2,8
Systematische Winkeltoleranz / <i>Stepangle Accuracy</i>		%	3
Widerstand pro Phase / <i>Phase Resistance</i>	R_{ph}	Ω	1,15
Induktivität pro Phase / <i>Phase Inductance</i>	L_{ph}	mH	2,1
Restdrehmoment / <i>Detent Torque</i>	M_P	Ncm	0,37
Isolationsklasse / <i>Insulation class</i>			B 130°
Max. Versorgungsspannung / Max. BUS Voltage DC	U	V_{DC}	48
Isolationswiderstand <i>Insulation Resistance</i>		MOhm	100
Durchschlagsfestigkeit / Dielectric Strength		VAC	500 1 minute
Rotorträgheitsmoment / <i>Rotor Inertia</i>	J	g.cm ²	115
Masse / <i>Mass</i>	m	kg	0,6
Wellendurchmesser/ A-Seite Shaft diameter A-Side		mm	5
Radial Belastung / <i>Radial shaft Load</i>	Shaft center	Kg	2,1
Axiale Belastung Axial shaft Load	Push/Pull	Kg	1
Schutzklasse / IP Rate		IP	20
Umgebungstemperatur / Ambient temperature		°C	-20 - +50

AHS Antriebstechnik GmbH, Fichtenweg 17, 64319 Pfungstadt; Phone: +49 6157 9866110 Fax: +49 6157 9866112

Anschlußplan / Connection Diagram

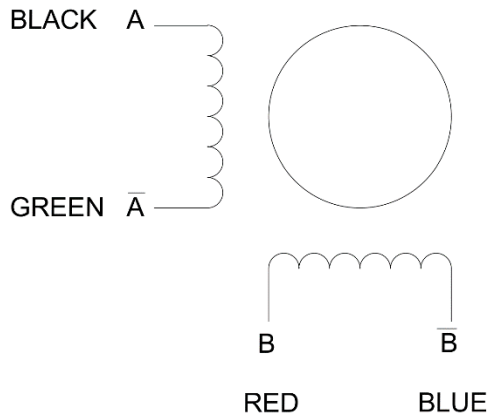

Kennlinie / Curve 2,8A

