

Abmessungen / Dimensions

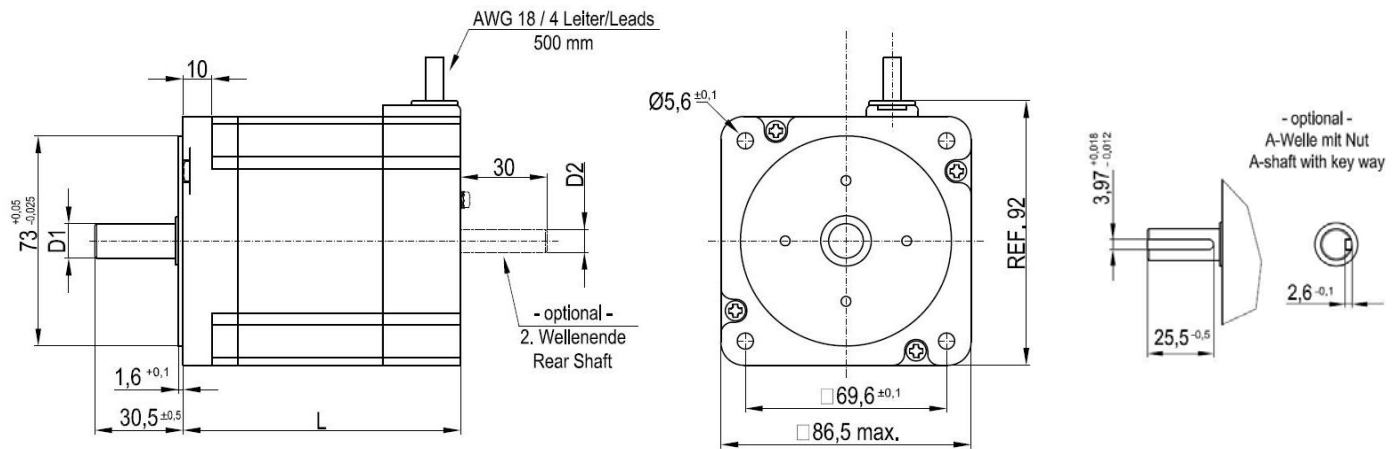

Anmerkungen / Notes: Alle Abmessungen in mm / All dimensions in mm

Motordaten / Motor Data													
Typ / Type:		Für xxx in der Bestellbezeichnung ist der entsprechende Buchstabe für den Wicklungsstrom einzutragen The xxx in the order code has to be replaced by the corresponding letter of the winding current											
HL3x-xxx-000401 (2 = rear shaft)				1-030	1-055	1-080	2-030	2-055	2-080	3-030	3-055	3-080	4-080
Haltemoment bipolar, parallel zwei Phasen bestromt / Holding Torque		M _H	Nm	5,5	5,5	5,5	7,5	7,5	7,5	10,0	10,0	10,0	12,0
Nennstrom pro Phase / Rated Phase Current		I	A	3,0	5,5	8,0	3,0	5,5	8,0	3,0	5,5	8,0	8,0
Tech. Daten / Tech. Data													
Systematische Winkeltoleranz / Stepangle Accuracy			%	5	5	5	5	5	5	5	5	5	5
Widerstand pro Phase / Phase Resistance		R _{ph}	Ω	1,37	0,42	0,19	1,56	0,46	0,22	1,70	0,55	0,29	0,33
Induktivität pro Phase / Phase Inductance		L _{ph}	mH	11,0	3,6	1,6	14,0	4,0	1,9	20,0	5,6	2,6	2,88
Restdrehmoment / Detent Torque		M _p	Ncm	20	20	20	20	20	20	30	30	30	35
Isolationsklasse / Insulation class				B	B	B	B	B	B	B	B	B	B
Max. Versorgungsspannung / Max. BUS Voltage DC		U	V _{DC}	160	160	160	160	160	160	160	160	160	160
Mech. Daten / Mech. Data													
Rotorträgheitsmoment / Rotor Inertia		J	g*cm ²	3460	3460	3460	3870	3870	3870	4900	4900	4900	8269
Masse / Mass		m	kg	3,0	3,0	3,0	4,0	4,0	4,0	4,9	4,9	4,9	5,4
Länge / Length		L	mm	96	96	96	124	124	124	142	142	142	158,5
Wellendurchmesser/ A-Seite Shaft diameter A-Side		D1	mm	12,0	12,0	12,0	12,0	12,0	12,0	12,0	12,0	12,0	12,0
Wellendurchmesser/ B-Seite Shaft diameter B-Side		D2	mm	8,00	8,00	8,00	8,00	8,00	8,00	8,00	8,00	8,00	8,00
Radial Belastung / 20mm vom A- Flansch			N	250	250	250	250	250	250	250	250	250	250
Axiale Belastung Axial shaft Load			N	60	60	60	60	60	60	60	60	60	60

Der Motor ist an einem Flansch angebaud und die Wicklungstemperaturanstieg ΔT = 90°C, Widerstand gemessen bei Wicklungstemperatur von 20°C
The motor is mounted, and winding temperature rise ΔT = 90°C. Resistance is with winding 20°C

AHS Antriebstechnik GmbH, Fichtenweg 17, 64319 Pfungstadt; Phone: +49 6157 9866110 Fax: +49 6157 9866112